



Technical Instruction ED_5660256_04_en
Motor-drive unit type TAPMOTION® ED
Questionnaire for motor protective switch tripping
Replacing ED_13002

Transformer Control
Service Engineer
Lohr Michael
Phone +49 941 40 90-7711
Telefax +49 941 40 90-7701
m.lohr@reinhausen.com
CST1/LOM
ED_5660256_00_en.docx

Regensburg, 07.06.2018

NOTICE

Safety, hazard and other information included in the MR operating instructions for motor-drive unit type TAPMOTION® ED must be observed!
Safety information for work performed on electrical systems must be observed!
All work must be carried out by sufficiently qualified personnel!

▲ WARNING Danger of death or severe injury!

If the motor-drive unit stops and the tap-change indicator pointer is not in the area marked gray, the tap-change operation has not been completed correctly.

This is a stationary state that is not allowed and it must be rectified immediately. If you cannot rectify the fault immediately, switch off the transformer.

Tripping of the motor protective switch can have numerous causes. If just one information detail is missing, it may not be possible to identify the cause of the incident clearly - especially if the trippings occur at irregular intervals.

Therefore, please fill in the questionnaire carefully for every single tripping of the motor protective switch in motor-drive unit type TAPMOTION® ED.

Always ensure that the transformer is de-energized before continuing.

Unauthorized copying and distribution of this document and the utilization and communication of its contents are strictly prohibited unless expressly authorized. Offenders will be held liable for the payment of damages. All rights reserved in the event of the grant of a patent, utility model or ornamental design registration.

1 General information

Serial number: _____

Operator: _____

Date: _____

Contact: _____

E-mail address: _____

Phone number: _____

Substation: _____

Operating site: _____

Address: _____

2 Motor-drive unit data

Additional information:

Current number of tap-change operations (see operations counter): _____

Set tripping current of motor protective switch (see Fig 1, red mark): _____ [A]

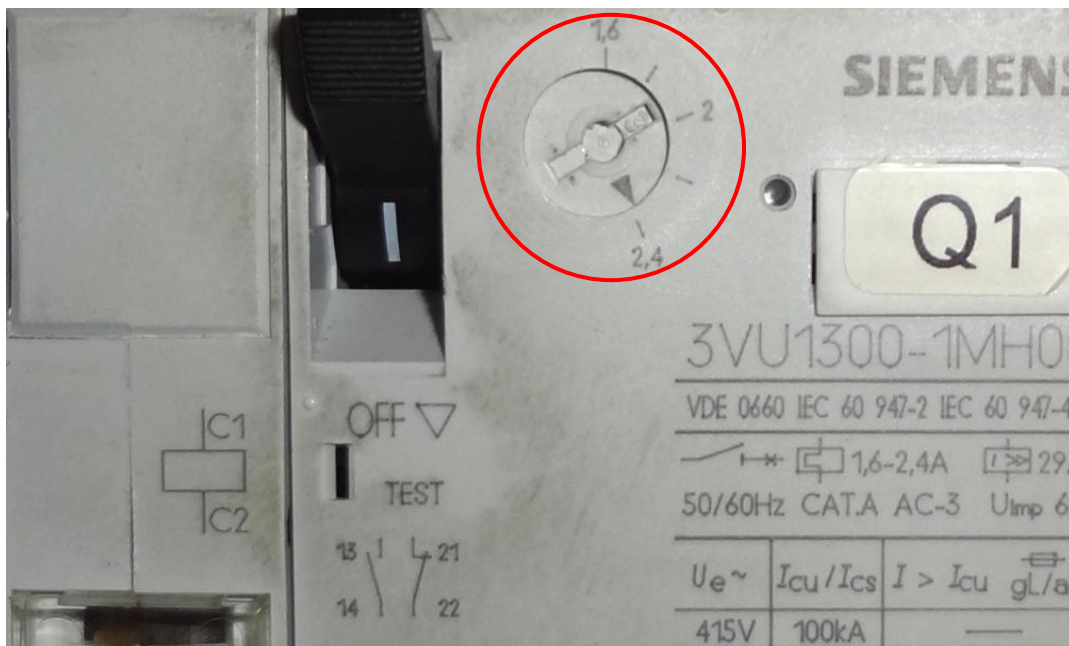

Fig. 1: Setting of tripping current of motor protective switch

3 Details about tripping of motor protective switch

Note: Please mark accordingly

In Fig. 2, please mark position of the tap-change indicator pointer (see Fig. 4: small pointer in inspection window of motor-drive unit) after tripping of the motor protective switch.

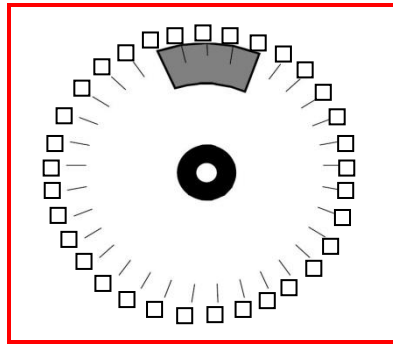

Fig 2: Tap-change indicator

Can the motor protective switch be switched on again after tripping? Yes No

If yes:

After closing Q1, the tap-change indicator pointer (small pointer in Fig. 4) turns:

- clockwise
- counterclockwise

(When Q1 trips again, operate motor-drive unit using hand crank; specify direction into which the pointer starts turning immediately after turning the hand crank)

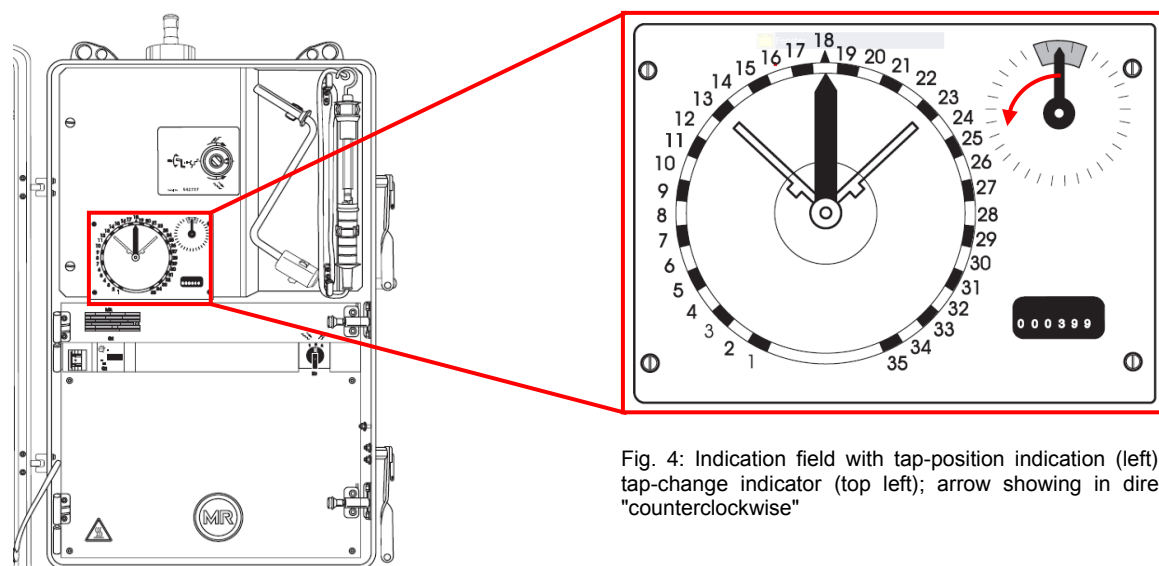

Fig. 3: Front view motor-drive unit type TAPMOTION® ED

with opened protective housing cover

Continued on next page

Details about tripping of motor protective switch – continued

When did the tripping of the motor protective switch occur?

Date and time of tripping of motor protective switch: _____

- during an electrical tap-change operation
- hand crank operation
- standstill of motor-drive unit
- not known

In which operating positions does the motor protective switch trip?

(Please use operating position indication of the motor drive unit!)

- in all operating positions

If yes, in which switching direction does the tripping occur?

- Both switching directions switching direction 1 → n switching direction n → 1

from operating position _____ to operating position _____

from operating position _____ to operating position _____

from operating position _____ to operating position _____

(Example: from operating position 7 to operating position 8)

In the operating positions listed above, the tripping occurs:

- always
- sporadically (after every _____ tap-change operations)

Continued on next page

Details about tripping of motor protective switch – continued

Is the motor-drive unit connected as indicated in the connection diagram?

Yes No

If no, what is different (e.g., voltage, frequency)?

Is connection terminal for external tripping of motor protective switch (usually X1:15, see Fig. 5) connected?

Yes No

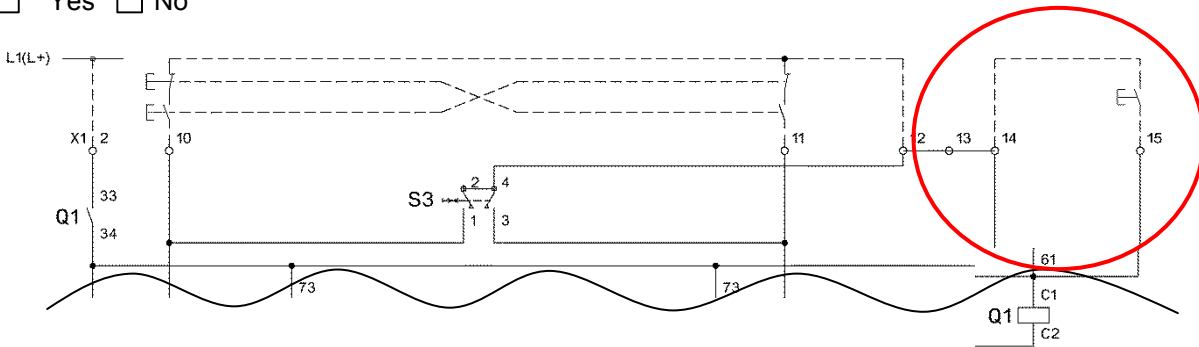

Fig. 5: Example – Extract from standard control circuit of motor-drive unit type TAPMOTION® ED (see connection terminal 15)

If yes, is voltage applied to trip coil terminal of motor protective switch?

Yes No

How long is the connecting lead? _____

For three-phase motors: Are the three phases of the supply voltage connected correctly (clockwise rotary field)? Yes No

Have other protective devices (e.g., external safety devices) responded that are connected before the voltage supply of the motor-drive unit?

Yes No not known

If yes, which (e.g., safety device type, tripping current, etc.)?

4 Additional information - please specify if available!

Year of commissioning of transformer:

Ambient temperature at the time of tripping of motor protective switch: _____ [°C]

Motor voltage and frequency during operation (measurement taken at motor terminal board):

Voltage between L1-L2: _____ [V]

Voltage between L2-L3: _____ [V]

Voltage between L3-L1: _____ [V]

Operating frequency: _____ [Hz]

Is the motor-drive unit equipped with a Monitoring System?

Yes No If yes, which?

TAPGUARD® Tap Manager® TM 100 Other: _____

Current consumption of motor during operation (across all operating positions):

Current in phase L1: _____ [A]

Current in phase L2: _____ [A]

Current in phase L3: _____ [A]

Were arcs visible in the area of the contactors just before tripping of the motor protective switch? (K1, K2, K20, possibly K3, etc. are located on the rear of the swing frame.)

Yes at contactor: _____

No

Are the external control contacts for the Raise / Lower pulses interlocked at the control room?

(This prevents simultaneous actuation.)

Yes No

Continued on next page

Additional information – continued

Which control options for the motor-drive unit are available? What was their setting at the time of tripping of the motor protective switch?

- Local / remote switch; setting: local remote
- Voltage regulation, setting: manual mode Voltage regulator mode
- Control for passing through just one position, activated: Yes No
- Control for passing through several positions, activated: Yes No

Other: _____

Before the incident, was there a weather event near the substation that led to a voltage drop / power failure?

- Yes No

If yes, which? _____

Were switching operations performed in the electrical network before the incident?

- Yes No

If yes, which? _____

Were maintenance or modification measures performed in the substation before the incident, or was the cabling changed?

- Yes No

If yes, which? _____

Please send the completed questionnaire to the e-mail address service@reinhausen.com or to:

Maschinenfabrik Reinhausen GmbH
Falkensteinstr. 8
93059 Regensburg

Phone +49 (0)941 4090-0
Telefax +49 (0)941 4090-7001

Copies to: CTT, CTE, CTP, CTPS, CST, CST1-all, CST2-all, CST3-all, CST3 notice board, CST4-all, CSTA-all, CSxO-all, Technical Instructions, MR subsidiaries and representatives, Schalter.adm – TYP; Wiki-GOP