

ORDERING CODES		
MODEL	W.D.	CODE
CPR3-ME	ME	ABOCOOME03
CPR3-MT	MT	ABOCO0MT03

Average weight : ~2.5 Kg

RELAY OPERATES WITH GAS DISPLACEMENT 400 ± 50 cc

Dimensioni in mm

ACCESSORIES UPON CUSTOMER REQUEST

WIRING DIAGRAM

MOUNTING SKETCH

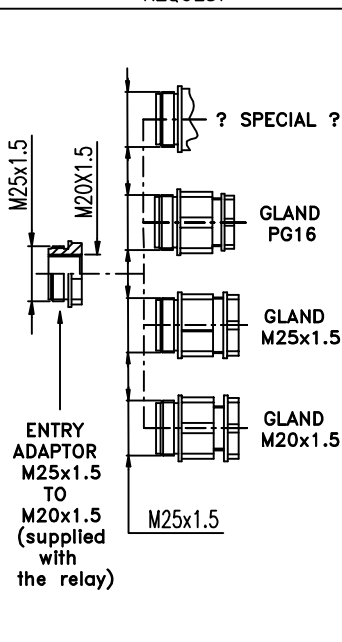

Pos.	EXEC. ME		EXEC. MT			Description
	1	2	1	2	3	
10						Earting screw
9						Cover
8						Mounting flange
7						Plug M25x1.5
6						Trip terminals
5						Cable entry M25-M20
4						Terminal box
3						Push button for checking electric circuits
2						Gas release cock (supplied with the relay)
1						Inspection window
0						Body

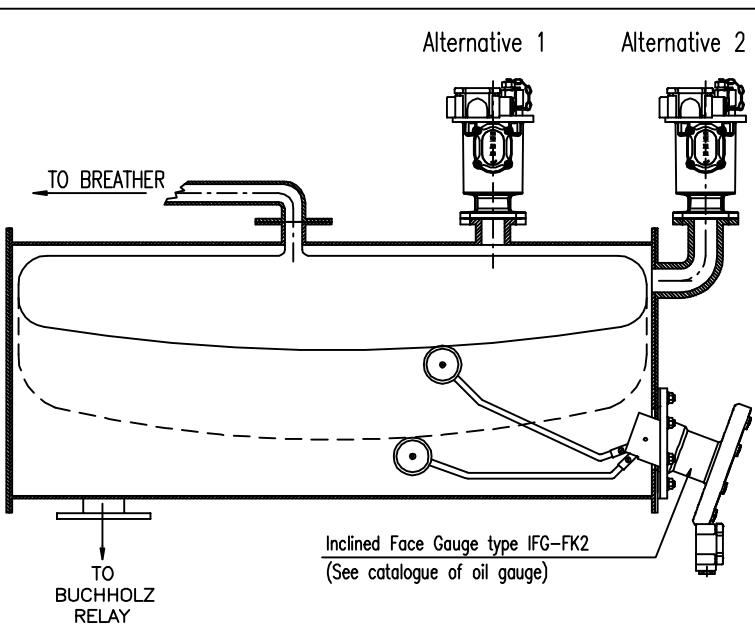

Titolo
Protective relay CPR3
 for rubber bag conservator

Data 08/08/12
 Scala 1:1
 Dis.
 Visto

Dis. Nr
3678

1	2	3		
---	---	---	--	--