

기술 데이터 VACUTAP® VR®. 부하시 탭 절환장치

Irm 700...3 200 A
5224510/09 KO

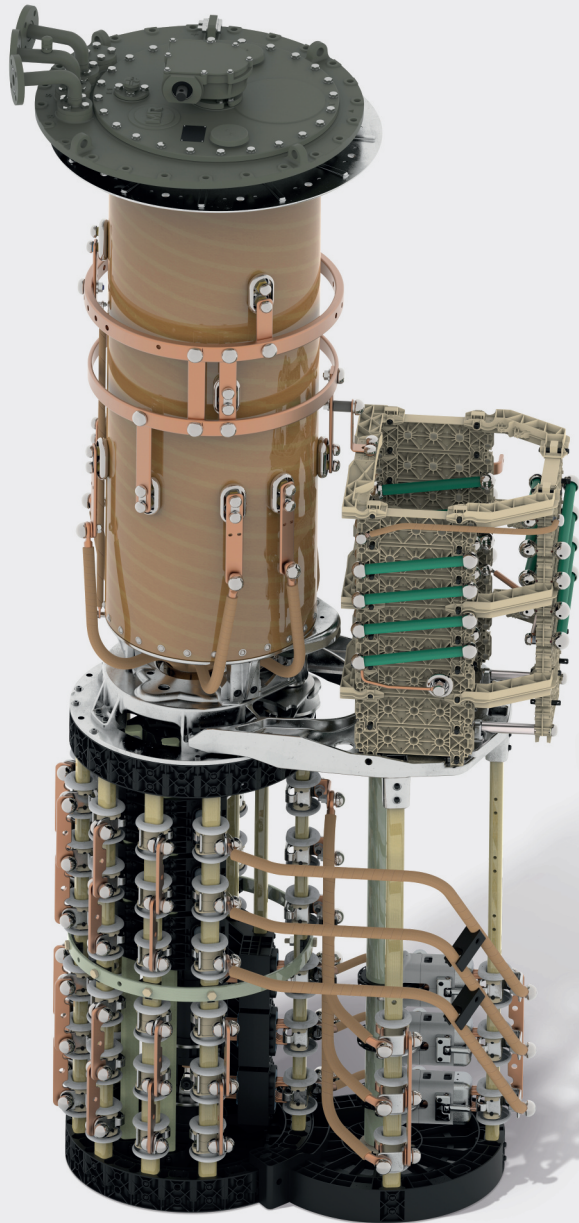

모든 저작권은 Maschinenfabrik Reinhausen에 있습니다.
본 문서의 배포 및 복제, 내용의 무단 전재 및 사용은 금지됩니다.
이를 위반할 경우 손해 배상의 의무가 있습니다. 특허 등록, 실용 신안 등록 및 디자인 등록에 대한 모든 권한은 Maschinenfabrik Reinhausen에 있습니다
본 문서의 편집 완료 이후에 제품과 관련하여 변경이 발생했을 수 있습니다.
기술 제원 혹은 구조 및 납품 범위가 변경될 수 있습니다.
원칙적으로 각각의 입찰 및 주문 처리 시 전달된 정보 및 체결된 합의가 구속력을 지닙니다.
본 사용 설명서의 원본은 독일어로 작성되었습니다.

목차

1 서론	5	4.2.9 10017865.....	66
1.1 부하시 탭 절환장치 명칭.....	5	4.2.10 10017858.....	68
1.1.1 부하시 탭 절환장치 유형 명칭의 예.....	5	4.2.11 10017861.....	70
1.1.2 위치 개수와 기본 연결.....	6	4.2.12 10017866.....	72
1.2 부하시 탭 절환장치 모델.....	7	4.2.13 10116984.....	74
1.3 기본 연결.....	7	4.2.14 10116986.....	76
		4.2.15 10020854.....	78
		4.2.16 10020855.....	80
		4.2.17 10020856.....	82
		4.2.18 10020857.....	84
		4.2.19 10171471.....	86
		4.2.20 10171472.....	88
		4.2.21 10171470.....	90
		4.2.22 10162477.....	92
		4.2.23 10162478.....	94
		4.2.24 10162474.....	96
		4.2.25 10162475.....	98
2 기술 데이터	10	4.3 설치 도면	100
2.1 부하시 탭 절환장치 속성.....	10	4.3.1 10017720.....	101
2.2 허용 주변 조건.....	13	4.3.2 10171473.....	102
2.3 스텝 용량 다이어그램.....	14	4.3.3 10017738.....	103
2.3.1 네트워크 응용 시 스텝 용량도.....	14	4.3.4 10162473.....	104
2.3.2 전기 아크로 구동 시 스텝 용량도.....	17	4.4 부하시 탭 절환장치 헤드	105
2.4 허용된 전압 응력.....	18	4.4.1 720026.....	106
2.4.1 절연 간격(다중 코스 체인지 오버 선택기 없음, 탭 선택기 크기 RES 없음).....	18	4.4.2 895168.....	107
2.4.2 탭 선택기 크기 B, C, D의 절연 간격, 다중 코스 체인지 오버 선택기 있음.....	22	4.4.3 893899.....	108
2.4.3 선택기 크기 RES의 절연 간격.....	24	4.4.4 10011023.....	109
2.5 실현 가능한 연결.....	27	4.4.5 720781.....	110
2.6 탭 권선 전위 연결.....	30	4.4.6 720027.....	111
2.6.1 R 선택기의 회복 전압과 차단 전류.....	30	4.4.7 893896.....	112
2.6.2 M 선택기의 회복 전압과 차단 전류.....	32	4.4.8 766161.....	113
		4.5 선택기	114
		4.5.1 10009917.....	115
		4.5.2 10009030.....	116
		4.5.3 10016570.....	119
		4.5.4 10018046.....	122
		4.5.5 10135742.....	123
		4.5.6 10010019.....	124
		4.5.7 10017264.....	125
		4.5.8 723590.....	126
		4.5.9 10117014.....	127
		4.5.10 899941.....	128
		4.6 전위연결 기구	129
		4.6.1 10018004.....	130
		4.6.2 10018008.....	131
		4.6.3 10018011.....	132
		4.6.4 10018013.....	134
		4.6.5 10166767.....	136
		4.6.6 10166766.....	137
		4.6.7 10166768.....	138
		4.6.8 10166769.....	139
		4.6.9 10017725.....	140
		4.6.10 10017533.....	141
3 특수 설계	33		
3.1 델타 결선을 위한 부하시 탭 절환장치 조합.....	33		
3.2 다중 코스 체인지 오버 선택기가 있는 부하시 탭 절환장치.....	34		
3.3 오픈형 중성점이 있는 Y 연결용 부하시 탭 절환장 치.....	34		
4 도면	35		
4.1 유형 개요.....	35		
4.1.1 10017427.....	36		
4.1.2 10017449.....	37		
4.1.3 10017453.....	38		
4.1.4 10017591.....	39		
4.1.5 10017622.....	40		
4.1.6 10017626.....	41		
4.1.7 10017697.....	42		
4.1.8 10017698.....	43		
4.1.9 10020883.....	44		
4.1.10 10117070.....	45		
4.1.11 10171577.....	46		
4.1.12 10162479.....	47		
4.1.13 10162476.....	48		
4.2 치수도.....	49		
4.2.1 10017856.....	50		
4.2.2 SED_5143008_00_001_2.....	52		
4.2.3 10017862.....	54		
4.2.4 10017863.....	56		
4.2.5 10017867.....	58		
4.2.6 SED_5144363_00_001_2.....	60		
4.2.7 10017860.....	62		
4.2.8 10017864.....	64		

4.6.11 898804	142
4.6.12 898690.....	143
4.6.13 898691	144
4.6.14 898692.....	145
4.6.15 788266.....	146
4.6.16 719733	147
4.7 결선도(예).....	148
4.7.1 5140296	149
4.7.2 5140298.....	150
4.7.3 5140300.....	151
4.7.4 5140417	152
4.7.5 5140418	153
4.7.6 5140419	154
4.7.7 5140630.....	155
4.7.8 5140631	156
4.7.9 5140632.....	157

1 서론

이 기술문서는 제품의 기술적 속성에 대한 정보를 담고 있습니다. 기본 정보는 "기술 데이터(TD 61) - 일반 절"에 나와 있습니다.

1.1 부하시 탭 절환장치 명칭

각각의 부하시 탭 절환장치 유형에는 여러 모델이 있고, 모델에 따라 상의 개수, 최대 정격 통과 전류, 장비 최고 전압 U_m , 탭 선택기 크기 및 기본 결선도가 다릅니다. 그러므로 부하시 탭 절환장치 모델의 명칭은 그 특징에 따라 다르며, 부하시 탭 절환장치 명칭을 착각하거나 잘못 해석할 여지가 없습니다.

1.1.1 부하시 탭 절환장치 유형 명칭의 예

부하시 탭 절환장치 VACUTAP® VRM III 1300 Y-72,5 / RC-10 19 1 WR

유형 명칭	VACUTAP® VRM III 1300 Y-72,5 / RC-10 19 1 WR	
VACUTAP® VRM	부하시 탭 절환장치 유형	
III	상수	
1300	마지막 숫자:	단상 부하시 탭 절환장치의 최대 정격 통과 전류 I_m (A)와 장착된 섹터의 개수 중성점이 있는 부하시 탭 절환장치를 사용할 경우 마지막 숫자가 0이면 3개의 섹터가 장착되어 있는 것입니다.
	끝에서 두 번째 숫자:	0 = 전류 분할 없음 2 = 2개의 병렬 분기 권선에 의한 강제 전류 분할이 필요합니다.
Y	중성점에 사용	
72.5	장비 최고 전압 U_m (kV)	
RC	탭 선택기 크기	
10 19 1 WR	기본 연결	

표 1: 부하시 탭 절환장치 명칭의 예

1.1.2 위치 개수와 기본 연결

선택기는 필요한 위치 개수와 탭 권선 연결에 대체로 맞출 수 있습니다. 기본 연결은 선택기 구분, 작동 위치의 개수, 중간 위치의 개수, 체인지 오버 선택기 모델, 전위 연결 유형 측면에서 차이가 있습니다.

예: 10 19 1 WR

기본 연결의 명칭	10 19 1 WR
10	선택기의 접점 원 피치
19	작동 위치의 최대 개수
1	중간 위치의 개수
W	체인지 오버 선택기 모델: W = 역 체인지 오버 선택기 G = 코스 탭 결선
R	전위 연결 유형: R = 연결된 타이인 저항기 S = 보드 위 타이인 스위치 및 타이인 저항기 P = 연결된 타이인 저항기가 있는 타이인 스위치

표 2: 기본 연결의 명칭 예

1.2 부하시 탭 절환장치 모델

유형 개요 [▶절 4.1, 페이지 35] 섹션에서 부하시 탭 절환장치 모델의 개요를 확인할 수 있습니다.

1.3 기본 연결

아래에는 부하시 탭 절환장치의 기본 연결과 MR 표준에 따른 탭 선택기 연결 접점의 명칭의 예가 몇 개 나와 있습니다. 실제 가능한 연결은 "허용된 전압 응력" [▶절 2.4, 페이지 18] 절에서 확인할 수 있습니다.



그림 1: 체인지 오버 선택기가 없는 기본 연결



그림 2: 리버싱 체인지 오버 파인 탭 선택기 결선의 기본 연결

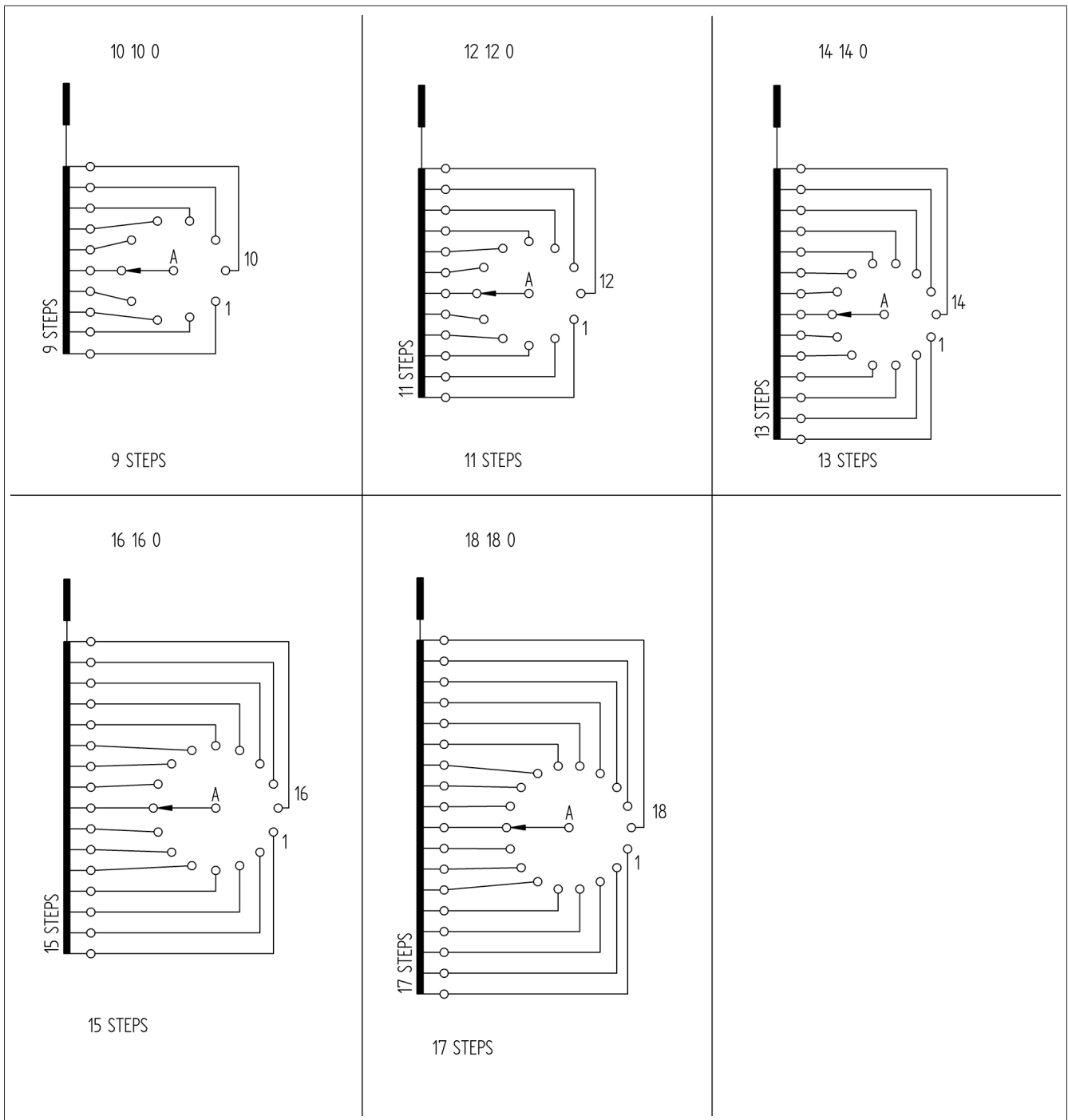

그림 3: 코스 맵 선택기 결선의 기본 연결

2 기술 데이터

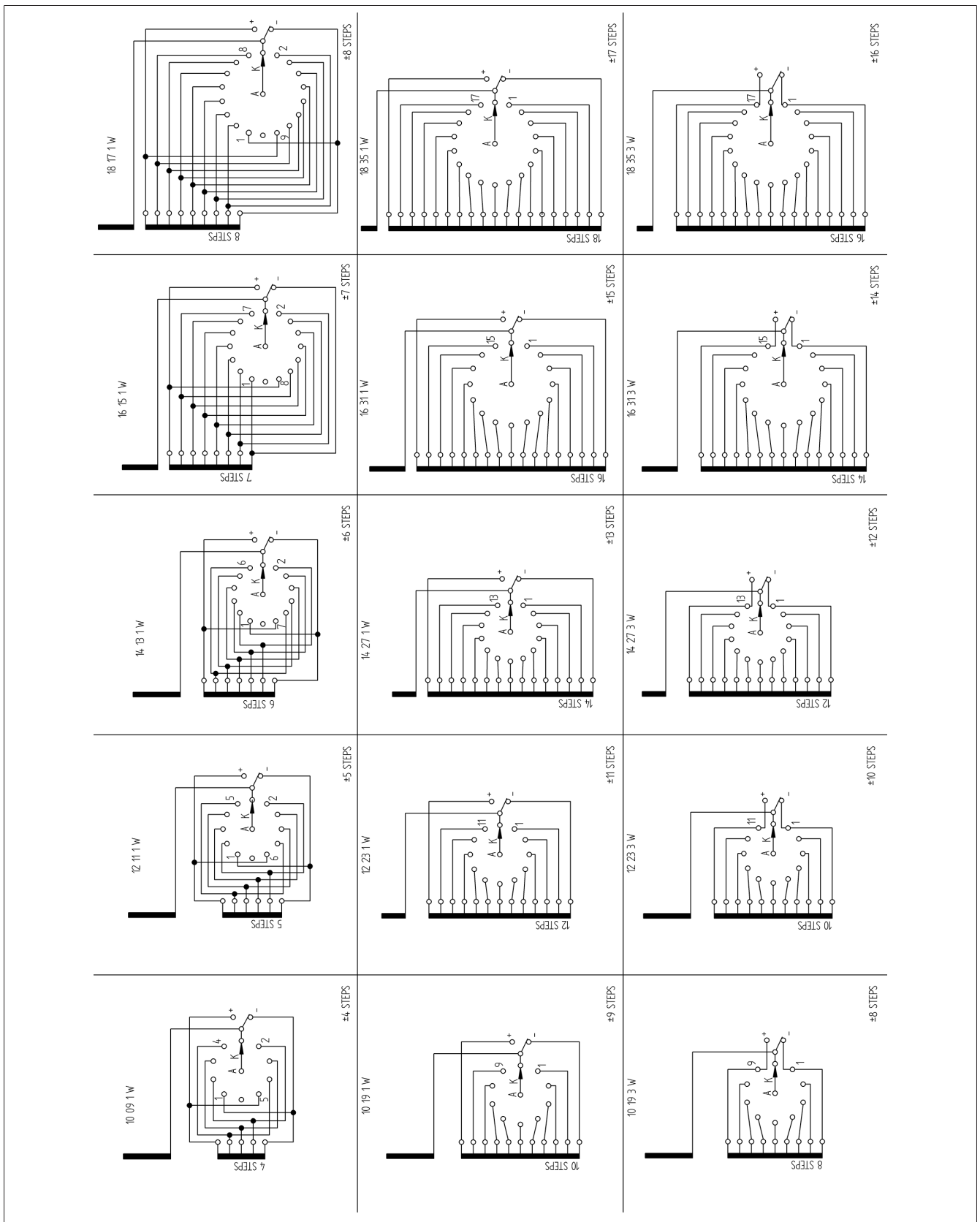
2.1 부하시 탭 절환장치 속성

VACUTAP® VR®의 전기 데이터, I_{rm} 700~1,300A, M-선택기

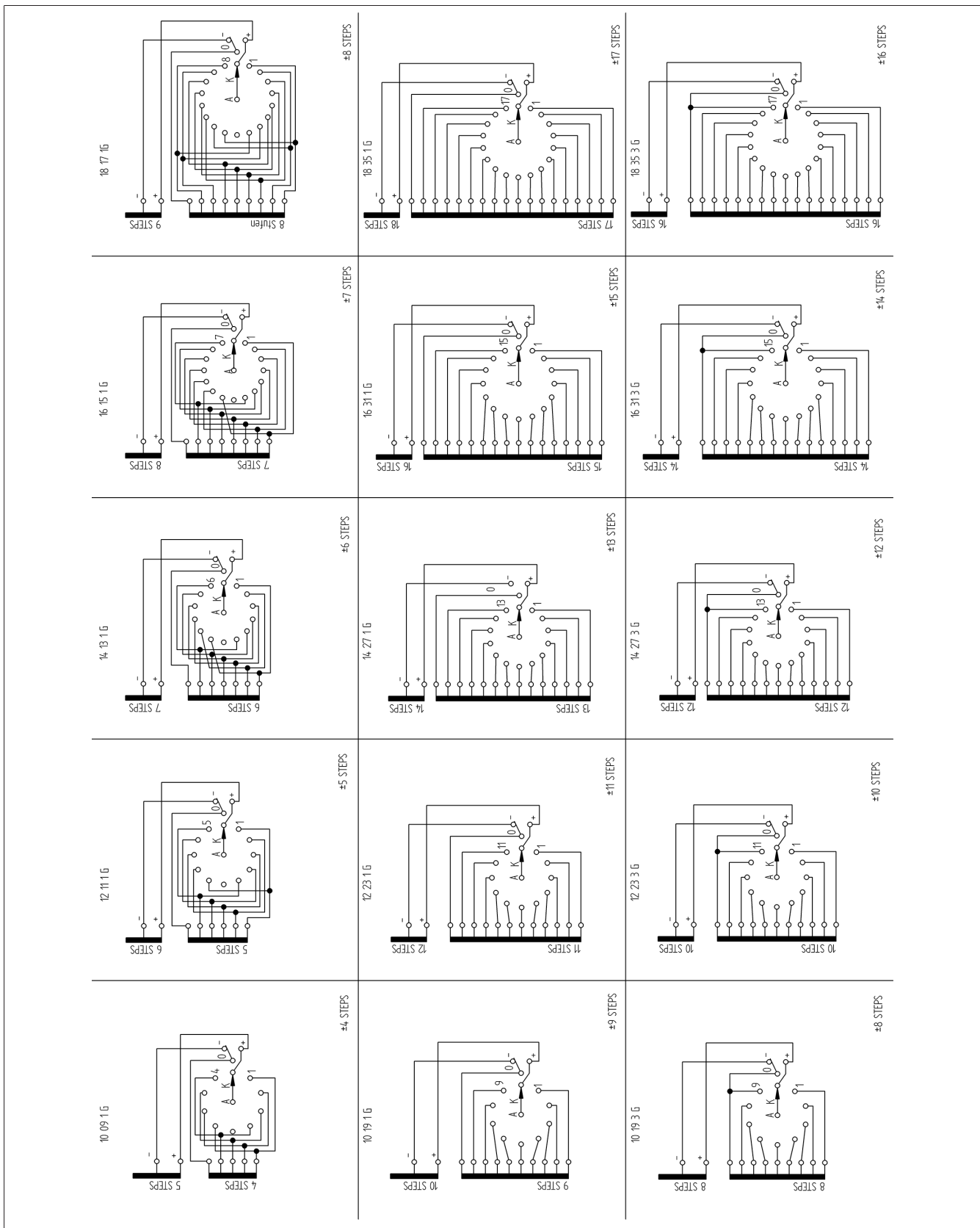
부하시 탭 절환장치	VRS I 701 VRS II 702 VRS III 700 Y	VRS I 1001	VRS I 1301
최대 정격 통과 전류 $I_{um}[A]$	700	1 000	1 300
정격 단시간 전류[kA]	10	12	16
정격 단락 시간[초]	3	3	3
정격 침투 내전류[kA]	25	30	40
최대 정격 스텝 전압 $U_{irm}[V]$	4 500	4 500	4 500
스텝 용량 $P_{stm}[kVA]$ ¹⁾	2 100 1 500	2 100 1 500	2 100 1 500
정격 주파수[Hz]	50~60		
¹⁾ 스텝 용량도 [▶ 절 2.3, 페이지 14] 참조			

표 3: VACUTAP® VRS의 전기 데이터

부하시 탭 절환장치	VRM I 701 VRM II 702 VRM III 700 Y	VRM I 1001	VRM I 1301
최대 정격 통과 전류 $I_{um}[A]$	700	1 000	1 300
정격 단시간 전류[kA]	10	12	16
정격 단락 시간[초]	3	3	3
정격 침투 내전류[kA]	25	30	40
최대 정격 스텝 전압 $U_{irm}[V]$	4 500	4 500	4 500
스텝 용량 $P_{stm}[kVA]$ ¹⁾	3 000	3 000	3 000
정격 주파수[Hz]	50~60		
¹⁾ 스텝 용량도 [▶ 절 2.3, 페이지 14] 참조			

표 4: VACUTAP® VRM의 전기 데이터

VACUTAP® VR®의 전기 데이터, I_{rm} 700...1 600 A, R-선택기

부하시 탭 절환장치	VRS I 701 VRS II 702 VRS III 700 Y	VRS I 1001 VRS II 1002 VRS III 1000 Y	VRS I 1301 VRS II 1302 VRS III 1300 Y	VRS I 2622 ¹⁾
최대 정격 통과 전류 $I_{um}[A]$	700	1 000	1 300	2 600
정격 단시간 전류[kA]	10	12	16	26
정격 단락 시간[초]	3	3	3	3
정격 침투 내전류[kA]	25	30	40	65
최대 정격 스텝 전압 $U_{irm}[V]$	4 500	4 500	4 500	4 500

부하시 탭 절환장치	VRS I 701 VRS II 702 VRS III 700 Y	VRS I 1001 VRS II 1002 VRS III 1000 Y	VRS I 1301 VRS II 1302 VRS III 1300 Y	VRS I 2622 ¹⁾
스텝 용량 P_{stm} [kVA] ²⁾	2 100 1 500	2 100 1 500	2 100 1 500	4 200 3 000
정격 주파수[Hz]	50...60			
¹⁾ 2개의 병렬 분기 권선에 의한 강제 전류 분할이 필요합니다. 전기 아크로 구동을 위한 용도가 아님				
²⁾ 스텝 용량도 [▶절 2.3, 페이지 14] 참조				

표 5: VACUTAP® VRS의 전기 데이터

부하시 탭 절환장치	VRM I 701 VRM II 702 VRM III 700 Y	VRM I 1001 VRM II 1002 VRM III 1000 Y	VRM I 1301 VRM II 1302 VRM III 1300 Y	VRM I 2622 ¹⁾
최대 정격 통과 전류 I_{um} [A]	700	1 000	1 300	2 600
정격 단시간 전류[kA]	10	12	16	26
정격 단락 시간[초]	3	3	3	3
정격 침투 내전류[kA]	25	30	40	65
최대 정격 스텝 전압 U_{irm} [V]	4 500	4 500	4 500	4 500
스텝 용량 P_{stm} [kVA] ²⁾	3 000	3 000	3 000	6 000
정격 주파수[Hz]	50...60			
¹⁾ 2개의 병렬 분기 권선에 의한 강제 전류 분할이 필요합니다. 전기 아크로 구동을 위한 용도가 아님				
²⁾ 스텝 용량도 [▶절 2.3, 페이지 14] 참조				

표 6: VACUTAP® VRM의 전기 데이터

부하시 탭 절환장치	VRL I 1301 VRL II 1302 VRL III 1300 Y	VRL I 1601 VRL III 1600 Y	VRL I 2622 ¹⁾
최대 정격 통과 전류 I_{um} [A]	1 300	1 600	2 600
정격 단시간 전류[kA]	16	16	26
정격 단락 시간[초]	3	3	3
정격 침투 내전류[kA]	40	40	65
최대 정격 스텝 전압 U_{irm} [V]	4 500	4 600	4 500
스텝 용량 P_{stm} [kVA] ²⁾	5 850	6 000	11 700
정격 주파수[Hz]	50...60		
¹⁾ 2개의 병렬 분기 권선에 의한 강제 전류 분할이 필요합니다. 전기 아크로 구동을 위한 용도가 아님			
²⁾ 스텝 용량도 [▶절 2.3, 페이지 14] 참조			

표 7: VACUTAP® VRL의 전기 데이터

• VACUTAP® VRH 및 VRX 부하시 탭 절환장치는 특수한 모델이며 요청 시에만 사용할 수 있습니다.

부하시 탭 절환장치	VRH I 651 VRH II 652 VRH III 650 Y	VRH I 1301 VRH II 1302 VRH III 1300 Y	VRH I 2622 ¹⁾	VRX I 652	VRX I 1302
최대 정격 통과 전류 I_{um} [A]	650	1 300	2 600	650	1300
정격 단시간 전류[kA]	10	16	26	10	16
정격 단락 시간[초]	3	3	3	3	3
정격 침투 내전류[kA]	25	40	65	25	40
최대 정격 스텝 전압 U_{im} [V]	6 000	6 000	6 000	12 000 ²⁾	12 000 ²⁾
스텝 용량 P_{stm} [kVA] ³⁾	3 000	6 000	12 000	6 000	12 000
정격 주파수[Hz]	50...60				

¹⁾ 2개의 병렬 분기 권선에 의한 강제 전류 분할이 필요합니다. 전기 아크로 구동을 위한 용도가 아님
²⁾ 필요한 권선 수 2배 [▶절 2.4, 페이지 18]
³⁾ 스텝 용량도 [▶절 2.3, 페이지 14] 참조

표 8: VACUTAP® VRH/VRX의 전기 데이터

VACUTAP® VR®의 전기 데이터, I_{rm} 1,800~3,200A, R-선택기

부하시 탭 절환장치	VRL I 1801	VRL I 2001	VRL I 2401	VRL I 2601	VRL I 3001	VRL I 3201
최대 정격 통과 전류 I_{um} [A]	1 800	2 000	2 400	2 600	3 000	3 200
정격 단시간 전류[kA]	20	24	24	26	30	32
정격 단락 시간[초]	3	3	3	3	3	3
정격 침투 내전류[kA]	50	60	60	65	75	80
최대 정격 스텝 전압 U_{im} [V]	6 000	6 000	6 000	6 000	6 000	6 000
스텝 용량 P_{stm} [kVA] ¹⁾	10 000	10 000	10 000	10 000	10 000	10 000
정격 주파수[Hz]	50~60					

¹⁾ 스텝 용량도 [▶절 2.3, 페이지 14] 참조

표 9: VACUTAP® VRL의 전기 데이터

VACUTAP® VR®의 기계 데이터

작동 위치 개수	체인지 오버 선택기 없음: 최대 18개 체인지 오버 선택기 있음: 최대 35개 다중 코스 체인지 오버 선택기 있음: 최대 107개
장착된 섹터 개수	1...3
탭 선택기 크기	R 선택기: RC, RD, RDE, RE, RF, RES, E M 선택기: B, C, D, DE
치수	치수도 [▶절 4.2, 페이지 49] 참조
중량	
변위 및 오일 체적	

표 10: VACUTAP® VR®의 기계 데이터

2.2 허용 주변 조건

운전 중 대기 온도	-25°C~+50°C
운전 중 절연유 온도	-25°C~+105°C(변압기 비상 가동 시 최고 +115°C)
수송 온도, 보관 온도	-40°C...+50°C
건조 온도	조립 및 작동 개시 설명서의 "장착" 장 참조
압축 강도	기술 데이터 TD 61 - 일반 절 참조
Insulating fluid	<ul style="list-style-type: none"> - IEC60296 및 ASTM D3487(요청 시 동등한 표준)에 따라 석유 제품¹⁾에서 얻은 미사용 절연유 - IEC60296에 따라 다른 버진 탄화수소 물질에서 얻은 미사용 절연유, 또는 이런 절연유를 IEC60296 및 ASTM D3487 또는 요청 시 동등한 표준에 따라 석유 제품¹⁾과 섞은 혼합물 - 요청 시 천연 및 합성 에스테르 또는 실리콘 오일 같은 대체 절연유 제공. <p>¹⁾ 여기서 GTL(Gas-to-liquid) 오일은 석유 제품으로 간주됩니다.</p>
오일 컨서베이터의 설치 높이	기술 데이터 TD 61 - 일반 절 참조
해발 설치 높이	기술 데이터 TD 61 - 일반 절 참조

표 11: 허용 주변 조건

2.3 스텝 용량 다이어그램

2.3.1 네트워크 응용 시 스텝 용량도



그림 4: 스텝 용량(정격 전압 U_n , 정격 통과 전류 I_r), *로 표시된 부하시 탭 절환장치 유형은 요청 시에만 사용할 수 있습니다.



그림 5: 스텝 용량(정격 전압 U_r , 정격 통과 전류 I_r), *로 표시된 부하시 탭 절환장치 유형은 요청 시에만 사용할 수 있습니다.

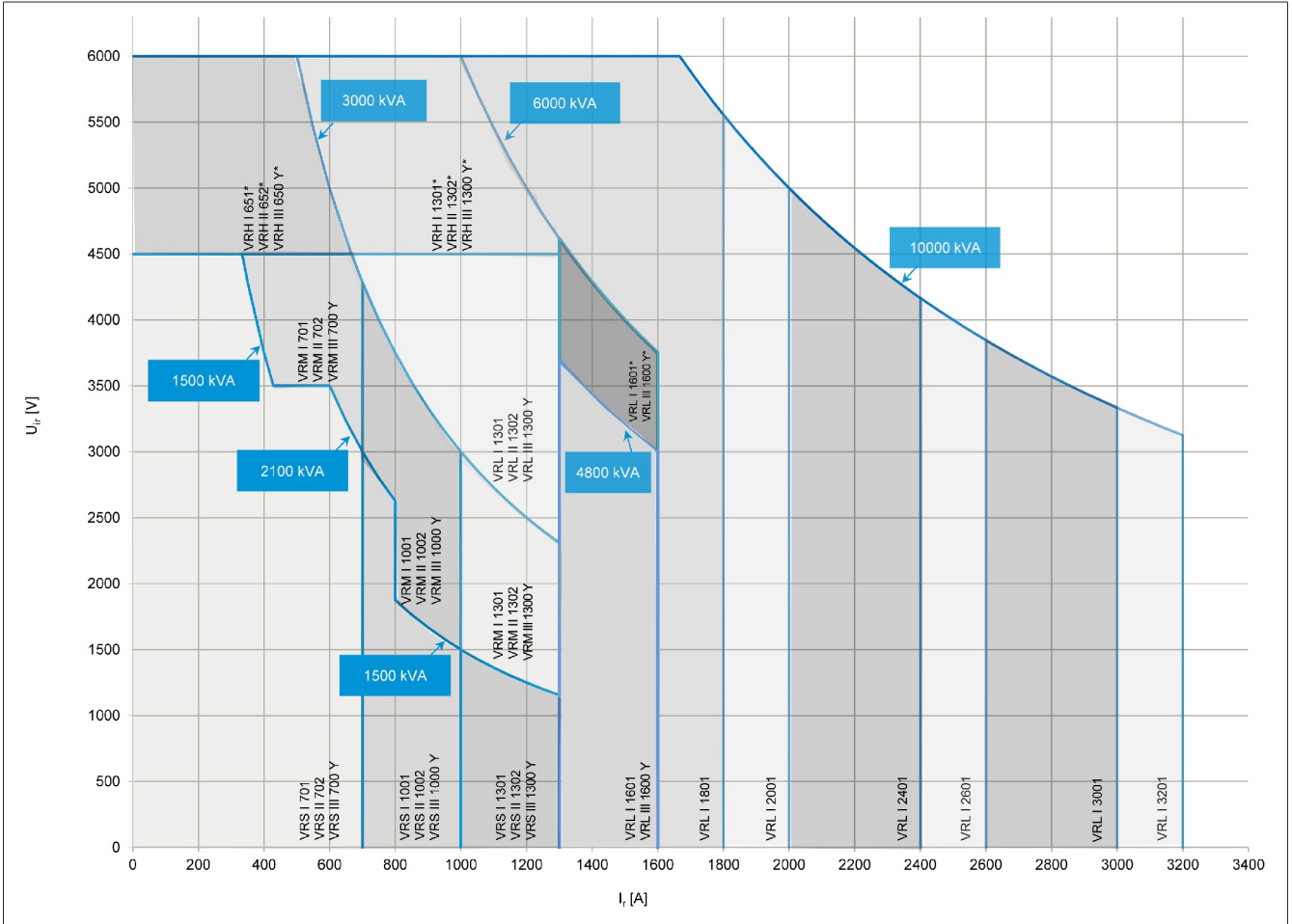

그림 6: 스텝 용량(정격 전압 U_{ir} , 정격 통과 전류 I_r), *로 표시된 부하시 탭 절환장치 유형은 요청 시에만 사용할 수 있습니다.

2.3.2 전기 아크로 구동 시스템 용량도

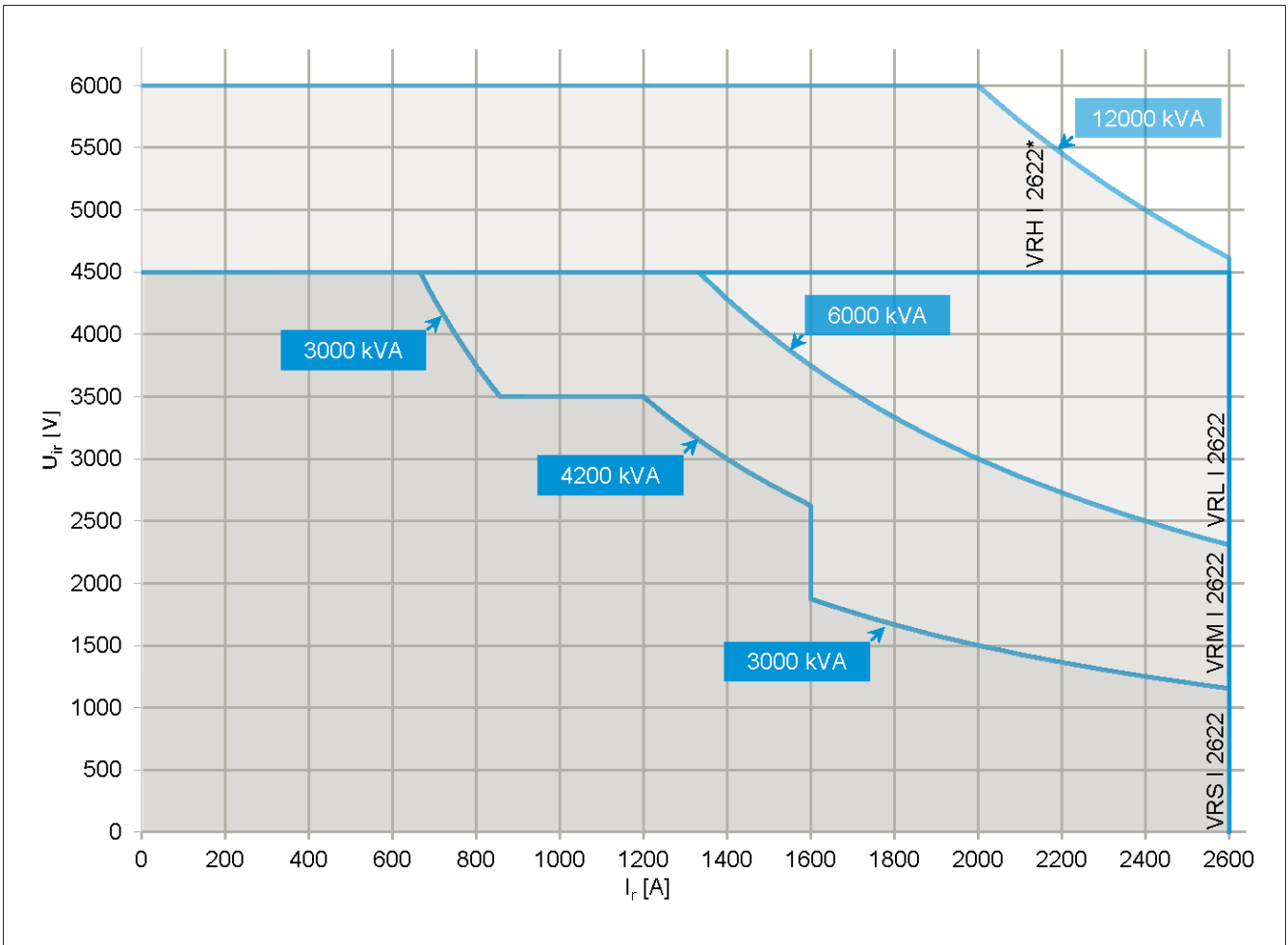

그림 7: 스텝 용량(정격 전압 U_r , 정격 통과 전류 I_r), *로 표시된 부하시 탭 절환장치 유형은 요청 시에만 사용할 수 있습니다.

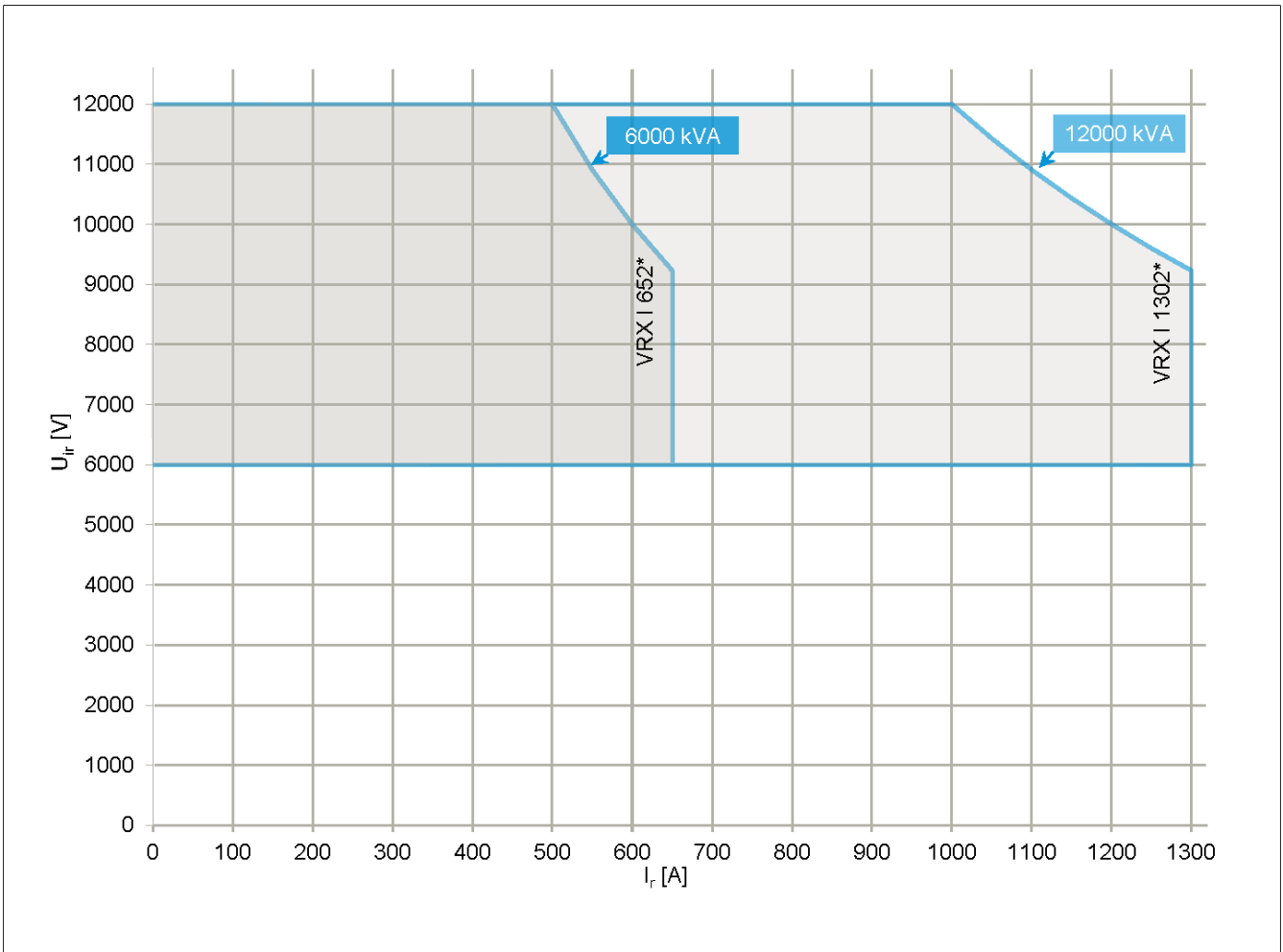
2.4 허용된 전압 응력

이 절은 부하시 탭 절환장치에 허용된 전압 응력을 설명합니다.

부하시 탭 절환장치를 선택할 때는 최고 응력이 절연 간격에서 관련 정격 내전압을 초과하지 않는지 확인해야 합니다.

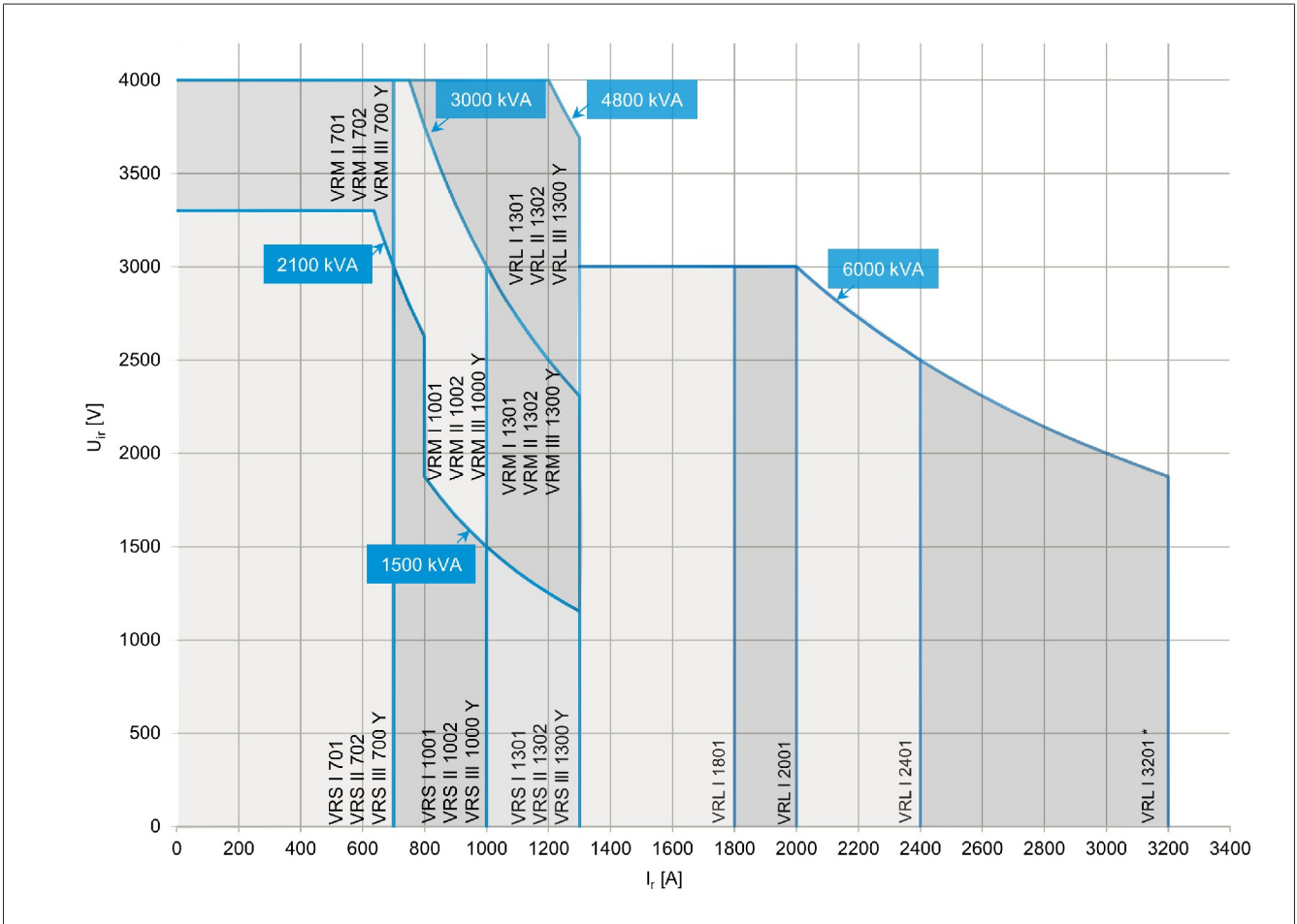
2.4.1 절연 간격(다중 코스 체인지 오버 선택기 없음, 탭 선택기 크기 RES 없음)



그림 8: 탭 선택기 크기 RC, RD, RDE, RE, RF 및 B, C, D, DE의 절연 간격, 다중 코스 체인지 오버 선택기 없음

a0	다이버터 스위치에서 선택된 탭과 사전 선택된 탭 사이
a1	(연결되거나 연결되지 않은) 탭 위치 한 개 권선의 파인 탭 선택기 접점 사이
a	탭 권선 시작부터 끝까지 거리, 코스 권선 모델의 경우 코스 권선 시작부터 끝까지 거리. 체인지 오버 선택기의 (-) 위치에 코스 탭 선택기를 결선한 경우의 참고 사항: 특히 충격 전압이 가해질 때 K 파인 탭 선택기 접점에 연결된 코스 권선의 끝부터 동일 위상의 탭 권선 끝에 있는 파인 탭 선택기 접점까지 사이의 허용 내전압 "a"를 유의하십시오.

b	서로 다른 위상의 파인 탭 선택기 접점 사이 그리고 서로 다른 위상의 체인지 오버 선택기 접점 사이. 이 접점은 탭 권선의 시작/끝 또는 파인 탭 선택기 접점과 연결되어 있습니다.
f	다이버터 스위치 출력 단자와 접지 사이
또한 체인지 오버 선택기의 (+) 위치에 코스 탭 선택기를 결선한 경우:	
c1	하나의 (-) 체인지 오버 선택기 접점과 동일 위상의 인출선 사이
c2	서로 다른 위상의 (-) 체인지 오버 선택기 접점 사이

정격 절연 강도 약어

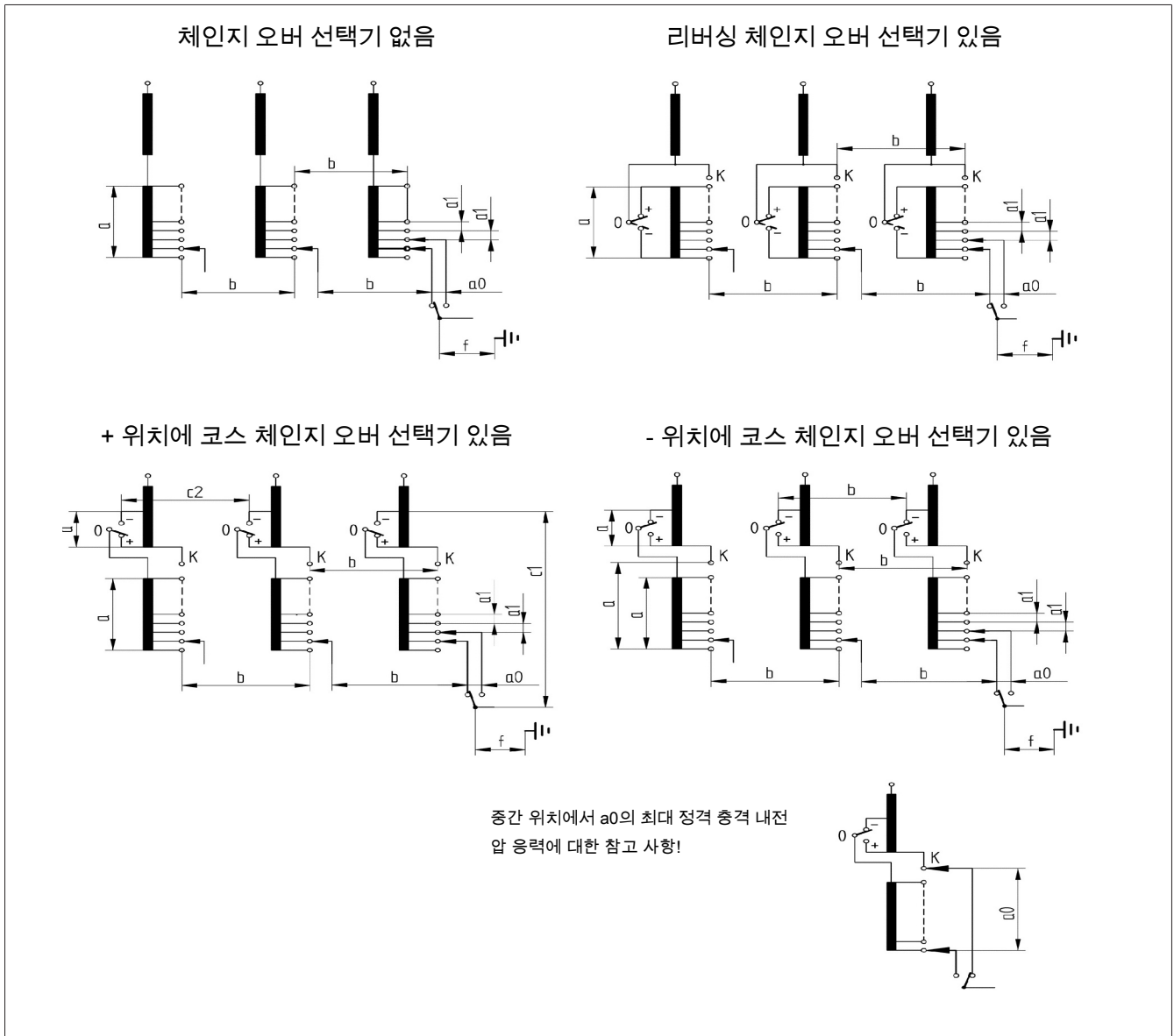
LI	전파 뇌충격(kV, 1.2/50 μ s)
LIC	재단파 뇌충격(kV, 1.2/50/3 μ s)
SI	개폐 충격 전압(kV, 250/2500 μ s)
AC	인가 전압(kV, 50Hz, 1분)

다이버터 스위치의 정격 절연 강도

절연 간격 f				
U_m ¹⁾	LI	LIC	SI	AC
72.5	350	385	-	140
123	550	605	460	230
170	750	825	620	325
245	1 050	1 155	850	460
300 ²⁾	1 050	1 155	850	460
362 ²⁾	1 175	1 290	950	510
420 ³⁾	1 425	1 570	1 175	630

표 12: 다이버터 스위치의 정격 절연 강도

¹⁾ IEC 60214-1에 따름: 부하시 탭 절환장치의 절연 설계에서 고려되는 3상 시스템 상간 전압의 최고 유효값

²⁾ 단상 부하시 탭 절환장치 및 2상 부하시 탭 절환장치 전용

³⁾ 단상 부하시 탭 절환장치 전용

R 선택기 내부 절연의 정격 절연 강도(탭 선택기 크기 RES 없음)

개별 선택기 간격의 허용 최대 작동 전압은 인가 전압(AC)에 대해 아래 나열된 값의 절반에 해당합니다.

절연 간격		탭 선택기 크기				
		RC	RD	RDE	RE	RF
a0	LI	150 ²⁾				
	LIC	165 ²⁾				
	SI	100 ²⁾				
	AC	20				

절연 간격		탭 선택기 크기					
		RC	RD	RDE	RE	RF	E
a1	LI	150					
	LIC	165					
	SI	100					
	AC	30					
a	LI	400	500	550	670	670	670
	LIC	440	550	605	735	735	735
	SI	260	325	355	435	435	435
	AC	100	145	165	220	220	180
b1 ¹⁾	LI	400	500	550	670	670	670
	LIC	440	550	605	735	735	735
	SI	260	325	355	435	435	435
	AC	120	160	180	220	280	180
c1	LI	550	590	660	900	900	820
	LIC	605	645	725	990	990	900
	SI	355	385	430	585	585	535
	AC	180	210	250	320	320	250
c2 ¹⁾	LI	550	590	660	930	1 000	820
	LIC	605	645	725	1 020	1 100	900
	SI	355	385	528	605	650	535
	AC	195	230	280	340	370	280

표 13: R 선택기 내부 절연의 정격 절연 강도

¹⁾ 단상 부하시 탭 절환장치에 해당하지 않음

²⁾ 1.2/50 μ s 뇌충격에서 배리스터 응답 전압: 45kV부터($U_{100\%}(t)_{standardized} \neq U_{75\%}(t)_{standardized}$), 3kA 침투 내전류에서 잔류 전압: 56kV

M 선택기 내부 절연의 정격 절연 강도(다중 코스 체인지 오버 선택기 없음)

개별 선택기 간격의 허용 최대 작동 전압은 인가 전압(AC)에 대해 아래 나열된 값의 절반에 해당합니다.

절연 간격		탭 선택기 크기			
		B	C	D	DE
a0	LI	150 ²⁾			
	LIC	165 ²⁾			
	SI	100 ²⁾			
	AC	20			

절연 간격		탭 선택기 크기			
		B	C	D	DE
a1	LI	150			
	LIC	165			
	SI	100			
	AC	30			
a	LI	265	350	490	550
	LIC	295	385	540	605
	SI	175	230	320	360
	AC	50	82	105	120
b1 ¹⁾	LI	265	350	490	550
	LIC	295	385	540	605
	SI	175	230	320	360
	AC	50	82	146	160
c1	LI	485	545	590	660
	LIC	535	600	650	725
	SI	315	355	385	430
	AC	143	178	208	230
c2 ¹⁾	LI	495	550	590	660
	LIC	545	605	650	725
	SI	325	360	385	430
	AC	150	182	225	250

표 14: M 선택기 내부 절연의 정격 절연 강도

¹⁾ 단상 부하시 탭 절환장치에 해당하지 않음

²⁾ 1.2/50 μ s 뇌충격에서 배리스터 응답 전압: 45kV부터($U_{100\%}(t)_{\text{standardized}} \neq U_{75\%}(t)_{\text{standardized}}$), 3kA 침투 내전류에서 잔류 전압: 56kV

2.4.2 탭 선택기 크기 B, C, D의 절연 간격, 다중 코스 체인지 오버 선택기 있음



그림 9: 탭 선택기 크기 B, C, D의 절연 간격, 다중 코스 체인지 오버 선택기 있음

a0	다이버터 스위치 상에서 선택된 탭과 사전 선택된 탭 사이
a1	(연결되거나 연결되지 않은) 하나의 탭 위치 권선의 파인 탭 선택기 접점 사이
a	탭 권선의 시작과 끝 사이 그리고 연결된 K 접점과 동일 위상의 탭 권선 임의 지점 사이
b	서로 다른 위상의 파인 탭 선택기 접점 사이 그리고 어떤 한 위상의 연결된 K 접점과 다른 위상의 탭 권선 임의 지점 사이
c1	한 위상의 임의 코스 탭과 동일 위상의 다이버터 스위치 출력 단자 사이
c2	서로 다른 위상에 있는 동일 이름의 연결되지 않은 코스 탭 사이
d1	같은 위상에 있는 연결된 코스 탭 접점과 인접 코스 탭 접점 사이
d2	같은 위상에 있는 연결되지 않은 인접 코스 탭 접점 사이
d3	동일 위상의 모든 코스 탭 연결의 시작과 끝 사이
f	다이버터 스위치 출력 단자와 접지 사이

절연 간격 f는 다이버터 스위치의 정격 절연 강도 [▶페이지 19]를 참조하십시오.

M 선택기 내부 절연의 정격 절연 강도, 다중 코스 체인지 오버 선택기 있음
 개별 선택기 간격에서의 허용 최대 작동 전압은 인가 전압(AC)에 대해 아래 나열된 값의 절반에 해당합니다.

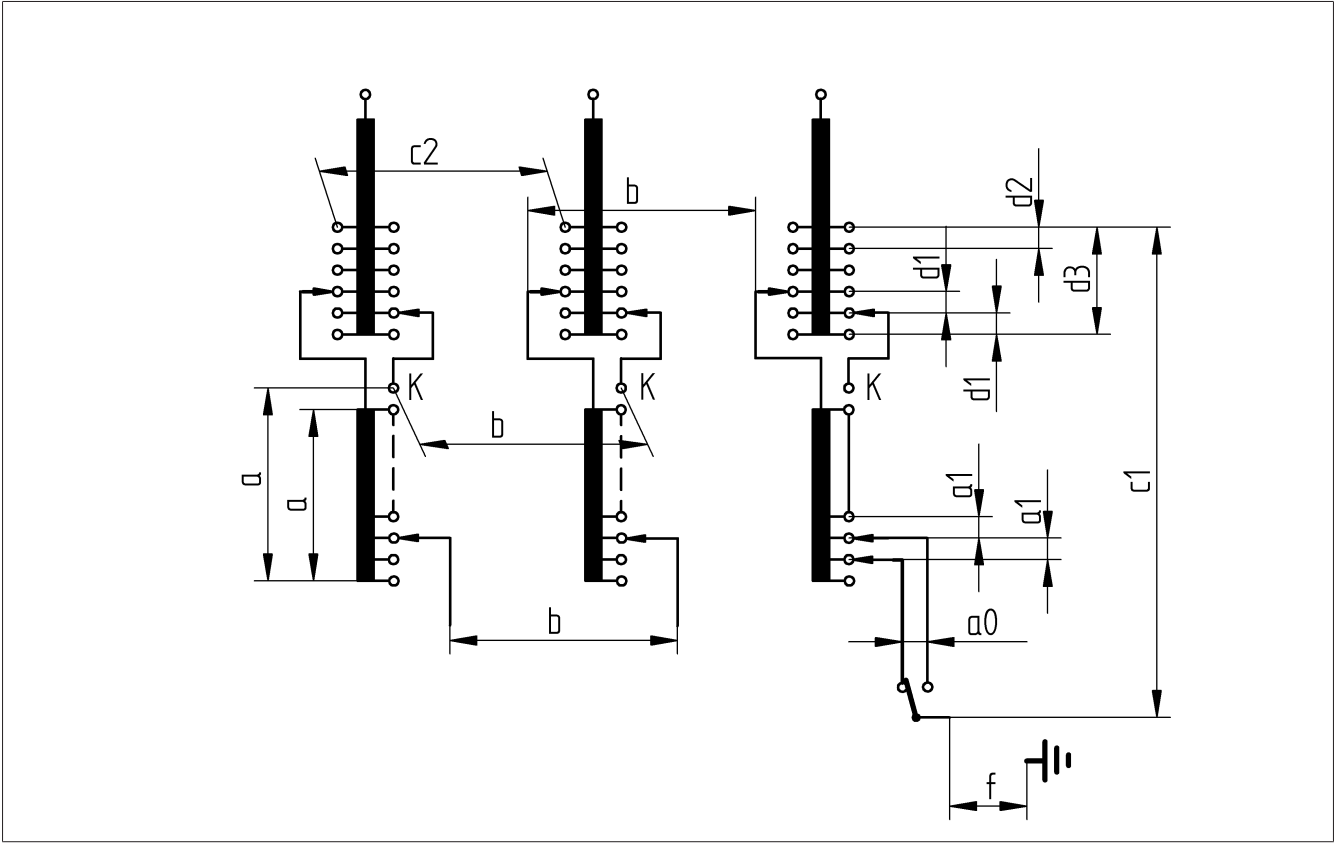
절연 간격		탭 선택기 크기		
		B	C	D
a0	LI	150 ²⁾		
	LIC	165 ²⁾		
	SI	100 ²⁾		
	AC	20		
a1	LI	150		
	LIC, SI	요청 시 값		
	AC	30		
a	LI	265	350	450
	LIC, SI	요청 시 값		
	AC	50	82	105
b ¹⁾	LI	265	350	450
	LIC, SI	요청 시 값		
	AC	50	82	146
c1	LI	455	525	590
	LIC, SI	요청 시 값		
	AC	127	165	210
c2 ¹⁾	LI	455	525	590
	LIC, SI	요청 시 값		
	AC	127	165	215
d1	LI	265	350	450
	LIC, SI	요청 시 값		
	AC	50	82	105
d2	LI	350	450	450
	LIC, SI	요청 시 값		
	AC	82	105	105
d3	LI	350	450	490
	LIC, SI	요청 시 값		
	AC	82	105	120

표 15: M 선택기 내부 절연의 정격 절연 강도, 다중 코스 체인지 오버 선택기 있음

¹⁾ 단상 부하시 탭 절환장치에 해당하지 않음

²⁾ 1.2/50 μ s 뇌충격에서 배리스터 응답 전압: 45kV부터($U_{100\%}(t)_{standardized} \neq U_{75\%}(t)_{standardized}$ 3kA 침투 내전류에서 잔류 전압: 70kV

2.4.3 선택기 크기 RES의 절연 간격

리버싱 체인지 오버 선택기 절연 간격



그림 10: 리버싱 체인지 오버 선택기 RES 절연 간격

a0	다이버터 스위치 상에서 선택된 탭과 사전 선택된 탭 사이
a1	(연결되거나 연결되지 않은) 하나의 탭 위치 권선의 파인 탭 선택기 접점 사이
a	탭 권선 시작과 끝 사이
a6	서로 다른 탭 권선의 파인 탭 선택기 접점 사이, 그리고 서로 다른 탭 권선의 체인지 오버 선택기 접점 사이. 이 접점은 탭 권선의 시작/끝 또는 파인 탭 선택기 접점과 연결되어 있습니다.
f	다이버터 스위치 출력 단자와 접지 사이

절연 간격 f는 다이버터 스위치의 정격 절연 강도 [▶페이지 19]를 참조하십시오.

코스 체인지 오버 선택기 절연 간격

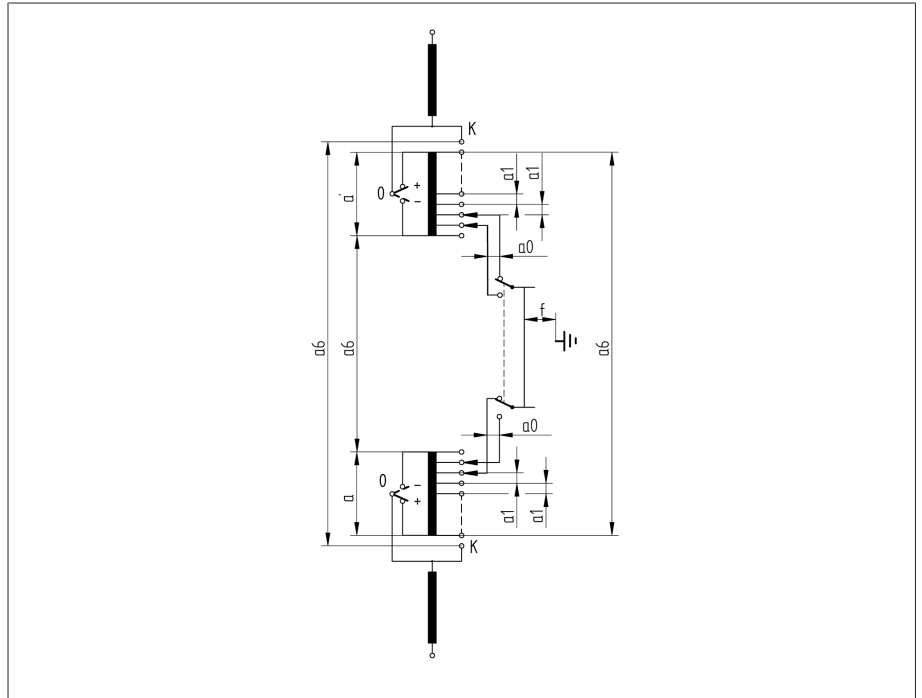
+ 위치에 코스 체인지 오버 선택기 있음

- 위치에 코스 체인지 오버 선택기 있음

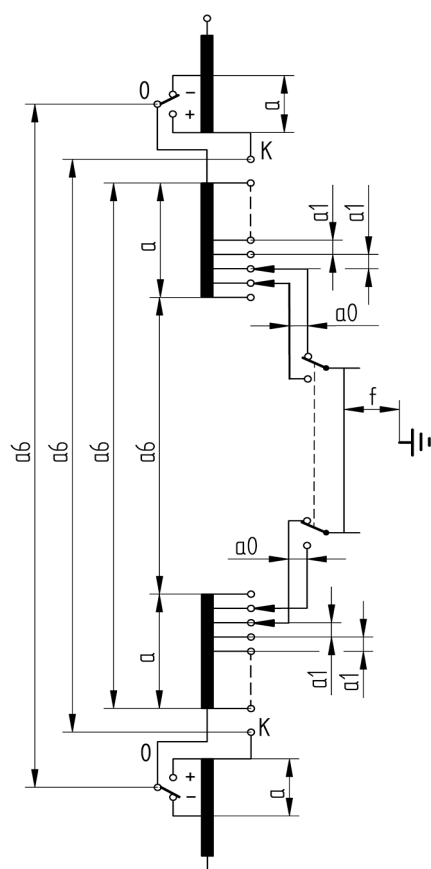
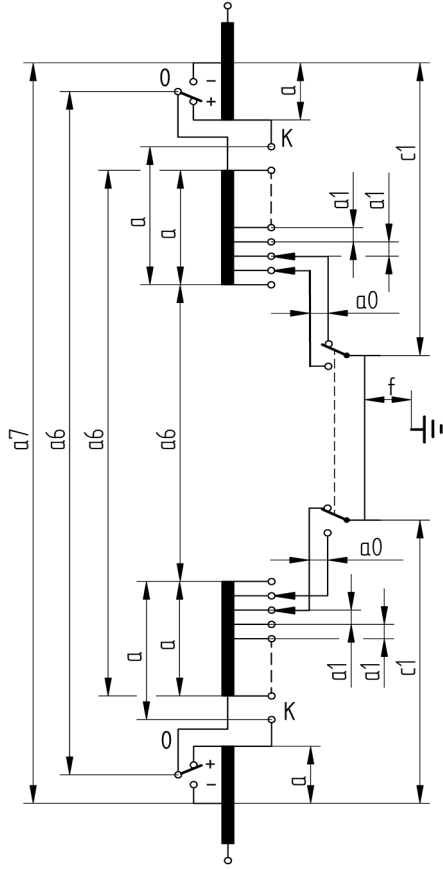

중간 위치에서 a0의 최대 정격 충격 내전압 응
력에 대한 참고 사항!



그림 11: 코스 체인지 오버 선택기 RES 절연 간격

a0	다이버터 스위치 상에서 선택된 탭과 사전 선택된 탭 사이
a1	(연결되거나 연결되지 않은) 하나의 탭 위치 권선의 파인 탭 선택기 접점 사이
a	탭 권선 시작부터 끝까지 거리, 코스 권선 시작부터 끝까지 거리. 체인지 오버 선택기의 (-) 위치에 코스 탭 선택기를 결선한 경우의 참고 사항: 충격 전압을 인가할 때는 K 파인 탭 선택기 접점에 연결된 코스 권선의 끝부터 동일 위상의 연결된 탭 권선의 끝에 있는 파인 탭 선택기 접점까지 사이의 허용 내전압 "a"를 유의하십시오.

a6	서로 다른 탭 권선의 파인 탭 선택기 접점 사이, 그리고 서로 다른 코스 권선의 체인지 오버 선택기 접점 사이. 이 접점은 탭 권선의 시작/끝 또는 파인 탭 선택기 접점과 연결되어 있습니다.
f	다이버터 스위치 출력 단자와 접지 사이
또한 체인지 오버 선택기의 (+) 위치에 코스 탭 선택기를 결선한 경우:	
c1	하나의 (-) 체인지 오버 선택기 접점과 인출선 사이
a7	(-) 체인지 오버 선택기 접점 사이

절연 간격 f는 다이버터 스위치의 정격 절연 강도 [▶페이지 19]를 참조하십시오.

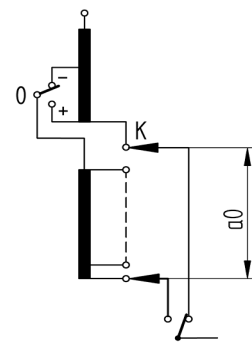
탭 선택기 크기 RES 내부 절연의 정격 절연 강도

개별 선택기 간격에서의 허용 최대 작동 전압은 인가 전압(AC)에 대해 아래 나열된 값의 절반에 해당합니다.

절연 간격		탭 선택기 크기		절연 간격		탭 선택기 크기	
		RES		RES			
a0	LI	150 ¹⁾	a6	LI	1 000		
	LIC	165 ¹⁾		LIC	1 100		
	SI	100 ¹⁾		SI	650		
	AC	20		AC	400		
a1	LI	150	a7	LI	1 200		
	LIC	165		LIC	1 320		
	SI	100		SI	780		
	AC	30		AC	500		
a	LI	670	c1	LI	900		
	LIC	735		LIC	990		
	SI	435		SI	585		
	AC	220		AC	320		

표 16: R 선택기 내부 절연의 정격 절연 강도

¹⁾ 1.2/50µs 뇌충격에서 배리스터 응답 전압: 45kV부터($U_{100\%}(t)_{standardized} \neq U_{75\%}(t)_{standardized}$, 3kA 침투 내전류에서 잔류 전압: 56kV

2.5 실현 가능한 연결

R 선택기, 탭 선택기 크기 RC/RD/RDE/RE/RF가 있는 VACUTAP® VR에 대한 실현 가능한 연결

아래에 나열된 연결도 역 체인지 오버 선택기 및 3개의 중간 위치(3W)가 있는 체인지 오버 선택기와 코스 탭 결선 및 3개의 중간 위치(3G)가 있는 체인지 오버 선택기에 실현될 수 있습니다.

체인지 오버 선택기 없음		역 체인지 오버 선택기 있음		코스 체인지 오버 선택기 있음	
탭 변환 구동	탭 선택기 크기	탭 변환 구동	탭 선택기 크기	탭 변환 구동	탭 선택기 크기
10050	RC/RD/RDE/RE/RF	10071W	RC/RD/RDE	10071G	RC/RD/RDE
10060	RC/RD/RDE/RE/RF	10081W	RC/RD/RDE	10081G	RC/RD/RDE
10070	RC/RD/RDE/RE/RF	10091W	RC/RD/RDE	10091G	RC/RD/RDE
10080	RC/RD/RDE/RE/RF	12101W	RC/RD/RDE	12101G	RC/RD/RDE
10090	RC/RD/RDE/RE/RF	14111W	RC/RD/RDE	14111G	RC/RD/RDE
10100	RC/RD/RDE/RE/RF	14121W	RC/RD/RDE	14121G	RC/RD/RDE
12110	RC/RD/RDE/RE/RF	16131W	RC/RD/RDE	16131G	RC/RD/RDE
12120	RC/RD/RDE/RE/RF	16141W	RC/RD/RDE	16141G	RC/RD/RDE
14130	RC/RD/RDE/RE/RF	18151W	RC/RD/RDE	18151G	RC/RD/RDE
14140	RC/RD/RDE/RE/RF	18161W	RC/RD/RDE	18161G	RC/RD/RDE
16150	RC/RD/RDE/RE/RF	10191W	RC/RD/RDE/RE/RF	10191G	RC/RD/RDE/RE/RF
16160	RC/RD/RDE/RE/RF	12231W	RC/RD/RDE/RE/RF	12231G	RC/RD/RDE/RE/RF
18170	RC/RD/RDE/RE/RF	14271W	RC/RD/RDE/RE/RF	14271G	RC/RD/RDE/RE/RF
18180	RC/RD/RDE/RE/RF	16311W	RC/RD/RDE/RE/RF	16311G	RC/RD/RDE/RE/RF
		18351W	RC/RD/RDE/RE/RF	18351G	RC/RD/RDE/RE/RF

표 17: R 선택기, 탭 선택기 크기 RC/RD/RDE/RE/RF가 있는 VACUTAP® VR에 대한 실현 가능한 연결

연결 12111W(G)에 따른 선택기는 14111W(G)에 따라 실현됩니다.

연결 14131W(G)에 따른 선택기는 16131W(G)에 따라 실현됩니다.

연결 16151W(G)에 따른 선택기는 18151W(G)에 따라 실현됩니다.

연결 18171W(G)에 따른 선택기는 실현될 수 없습니다.

탭 선택기 크기 RES는 3W/3G 디자인에만 사용 가능하고 연결 10193W(G)–18353W(G)에 대해 실현할 수 있습니다.

R 선택기, 탭 선택기 크기 E가 있는 VACUTAP® VR에 대한 실현 가능한 연결

역 체인지 오버 선택기 있음		코스 체인지 오버 선택기 있음	
탭 변환 구동	탭 선택기 크기	탭 변환 구동	탭 선택기 크기
10071W	E	10071G	E
10081W	E	10081G	E
10091W	E	10091G	E

역 체인지 오버 선택기 있음		코스 체인지 오버 선택기 있음	
12101W	E	12101G	E
12111W	E	12111G	E
14121W	E	14121G	E
14131W	E	14131G	E
16141W	E	16141G	E
18151W	E	18151G	E
18161W	E	18161G	E
10191W	E	10191G	E
12231W	E	12231G	E
14271W	E	14271G	E
16311W	E	16311G	E
18351W	E	18351G	E

표 18: R 선택기, 탭 선택기 크기 E가 있는 VACUTAP® VR에 대한 실현 가능한 연결

연결 10091W에 따른 선택기는 18091W에 따라 실현됩니다.

연결 12111W에 따른 선택기는 18111W에 따라 실현됩니다.

연결 14131W에 따른 선택기는 18131W에 따라 실현됩니다.

M 선택기, 탭 선택기 크기 B/C/D/DE가 있는 VACUTAP® VR에 대한 실현 가능한 연결

아래에 나열된 연결도 역 체인지 오버 선택기 및 3개의 중간 위치(3W)가 있는 체인지 오버 선택기와 코스 탭 결선 및 3개의 중간 위치(3G)가 있는 체인지 오버 선택기에 실현될 수 있습니다.

체인지 오버 선택기 없음		역 체인지 오버 선택기 있음		코스 체인지 오버 선택기 있음	
탭 변환 구동	탭 선택기 크기	탭 변환 구동	탭 선택기 크기	탭 변환 구동	탭 선택기 크기
10050	B/C/D/DE	10071W	B/C/D/DE	10071G	B/C/D/DE
10060	B/C/D/DE	10081W	B/C/D/DE	10081G	B/C/D/DE
10070	B/C/D/DE	10091W	B/C/D/DE	10091G	B/C/D/DE
10080	B/C/D/DE	12101W	B/C/D/DE	12101G	B/C/D/DE
10090	B/C/D/DE	12111W	B/C	12111G	B/C
10100	B/C/D/DE	14111W	D/DE	14111G	D/DE
12110	B/C/D/DE	14121W	B/C	14121G	B/C
12120	B/C/D/DE	14131W	B/C	14131G	B/C
14130	B/C/D/DE	16121W	D/DE	16121G	D/DE
14140	B/C/D/DE	16131W	D/DE	16131G	D/DE
16150	B/C/D/DE	16141W	B/C/D/DE	16141G	B/C/D/DE
16160	B/C/D/DE	16151W	B/C	16151G	B/C
18170	B/C/D/DE	18151W	D/DE	18151G	D/DE
18180	B/C/D/DE	18161W	B/C	18161G	B/C
		18171W	B/C	18171G	B/C

체인지 오버 선택기 없음		역 체인지 오버 선택기 있음		코스 체인지 오버 선택기 있음	
탭 변환 구동	탭 선택기 크기	탭 변환 구동	탭 선택기 크기	탭 변환 구동	탭 선택기 크기
		10191W	B/C/D/DE	10191G	B/C/D/DE
		12231W	B/C/D/DE	12231G	B/C/D/DE
		14271W	B/C/D/DE	14271G	B/C/D/DE
		16311W	B/C/D/DE	16311G	B/C/D/DE
		18351W	B/C/D/DE	18351G	B/C/D/DE

표 19: M 선택기, 탭 선택기 크기 B/C/D/DE가 있는 VACUTAP® VR에 대한 실현 가능한 연결

2.6 탭 권선 전위 연결

스위칭 구동 중에 탭 권선은 리버싱 체인지 오버 선택기 또는 코스 체인지 오버 선택기에 의해 잠깐 전원으로부터 차단됩니다. 그러면 탭 권선은 인접 권선의 전압과 그 권선 또는 접지 부품으로 인해 발생하는 결합 용량으로 인한 전위를 수용합니다.

하나의 접점은 언제나 탭 권선에 연결되고 다른 하나의 접점은 언제나 주 권선에 연결되기 때문에 탭 권선의 이러한 전위 전이는 비활성화된 체인지 오버 선택기 접점 사이에 그에 상응하는 전압을 만듭니다. 이 전압을 회복 전압 U_w 라고 합니다.

체인지 오버 선택기 접점을 분리할 때 용량성 전류가 차단되어야 합니다. 이 전류는 앞에서 말한 탭 권선의 결합 용량에 따라 다릅니다. 이 전류를 차단 전류 I_s 라고 합니다.

회복 전압 U_w 와 차단 전류 I_s 는 체인지 오버 선택기에서 허용치 이상의 방전을 초래할 수 있습니다. 허용 회복 전압 U_w 와 차단 전류 I_s 범위가 아래에 나열되었습니다.

2.6.1 R 선택기의 회복 전압과 차단 전류

AGIS("Active Gas Inhibition System")에서는 체인지 오버 선택기 작동 중에 발생하는 가스의 양을 줄여 줍니다. 회복 전압 및 차단 전류에 대한 자세한 내용은 기술 데이터 TD 61 - 일반 파트를 참조하십시오.

타이인 저항기가 없는 회복 전압 U_w 와 차단 전류 I_s



그림 12: 선택기 크기 RC, RD, RDE, RE, RF, RES에 대한 타이인 저항기 R_p 가 없을 때의 U_w 와 I_s 안내값

1	탭 선택기 크기 RC, RD, RDE(AGIS 미포함)	2	탭 선택기 크기 RC, RD, RDE(AGIS 포함)
3	탭 선택기 크기 RE, RF, RES(AGIS하고만 사용 가능)		

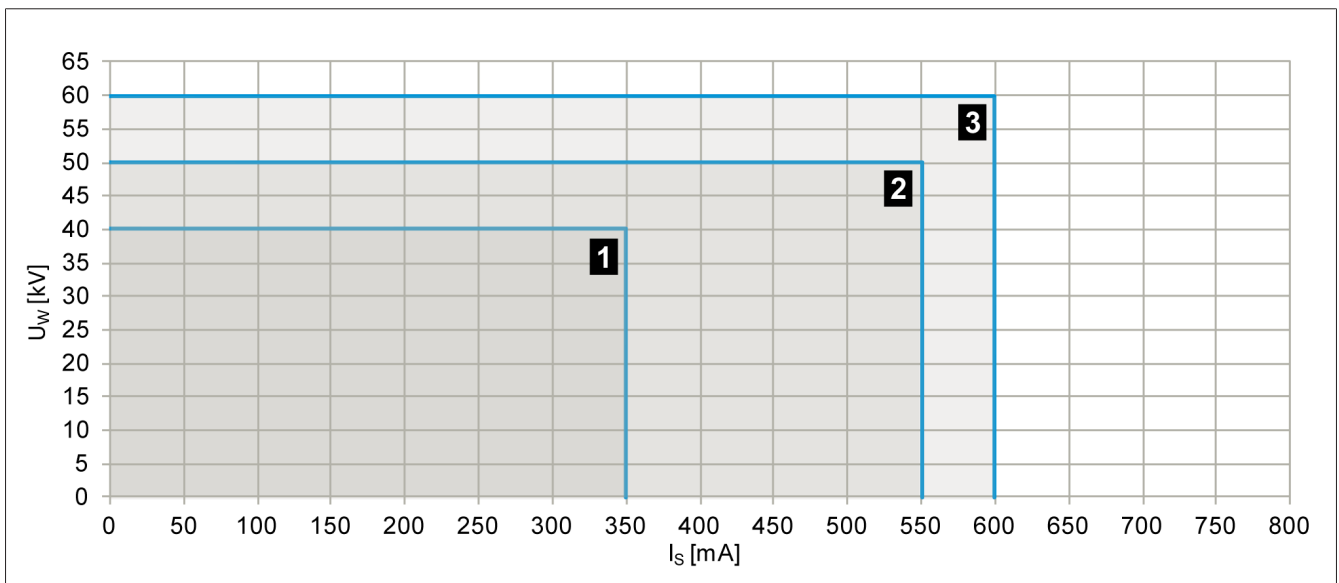

그림 13: 탭 선택기 크기 E에 대한 타이인 저항기 R_p 가 없을 때의 U_w 와 I_s 안내값

타이인 저항기가 있는 회복 전압 U_w 와 차단 전류 I_s

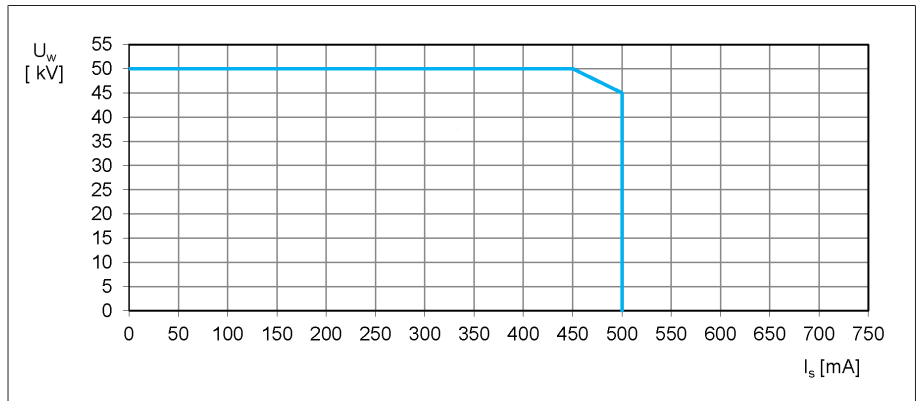

그림 14: 선택기 크기 RC, RD, RDE, RE, RF, RES에 대한 타이인 저항기 R_p 가 있을 때의 U_w 와 I_s 안내값

1	탭 선택기 크기 RC, RD, RDE(AGIS 미포함)	2	탭 선택기 크기 RC, RD, RDE(AGIS 포함)
3	탭 선택기 크기 RE, RF, RES(AGIS하고만 사용 가능)		

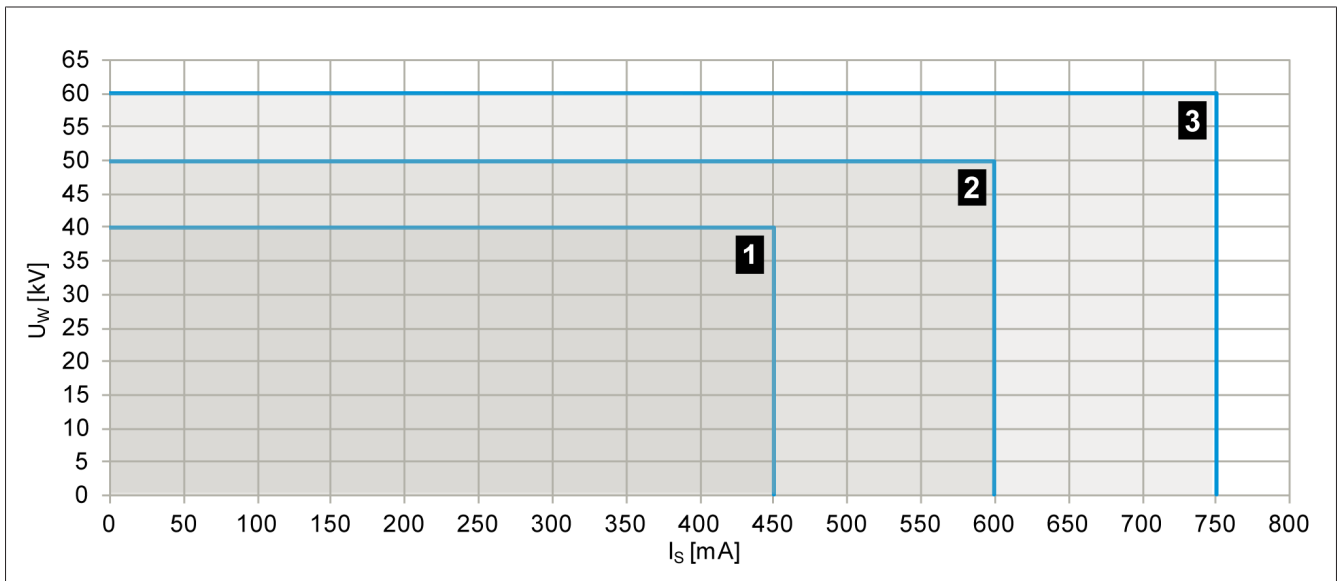

그림 15: 탭 선택기 크기 E에 대한 타이인 저항기 R_p 가 있을 때의 U_w 와 I_s 안내값

2.6.2 M 선택기의 회복 전압과 차단 전류

회복 전압 및 차단 전류에 대한 자세한 내용은 기술 데이터 TD 61 - 일반 파트를 참조하십시오.

타이인 저항기가 없는 회복 전압 U_w 와 차단 전류 I_s

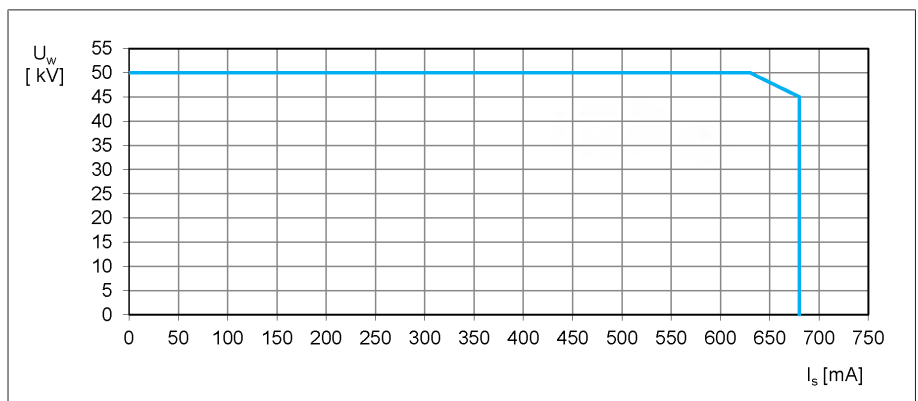

그림 16: 선택기 크기 B, C, D, DE에 대한 타이인 저항기 R_p 가 없을 때의 U_w 와 I_s 안내값

타이인 저항기가 있는 회복 전압 U_w 와 차단 전류 I_s

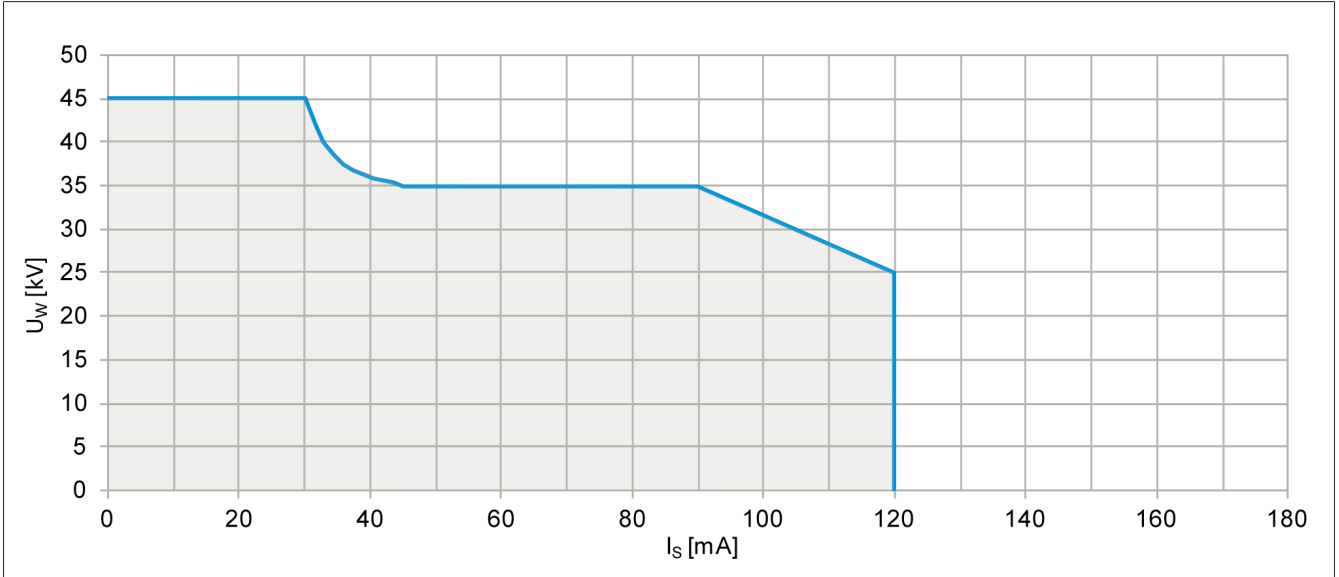

그림 17: 선택기 크기 B, C, D, DE에 대한 타이인 저항기 R_p 가 있을 때의 U_w 와 I_s 안내값

3 특수 설계

3.1 델타 결선을 위한 부하시 탭 절환장치 조합

단상 부하시 탭 절환장치는 2상 부하시 탭 절환장치와 결합하여 델타 결선에서 변압기 권선 전압을 설정할 수 있습니다. 이 2 칼럼 부하시 탭 절환장치 조합을 "VR III K"("K"는 독일어로 조합(Kombination)을 뜻함)라고 합니다.

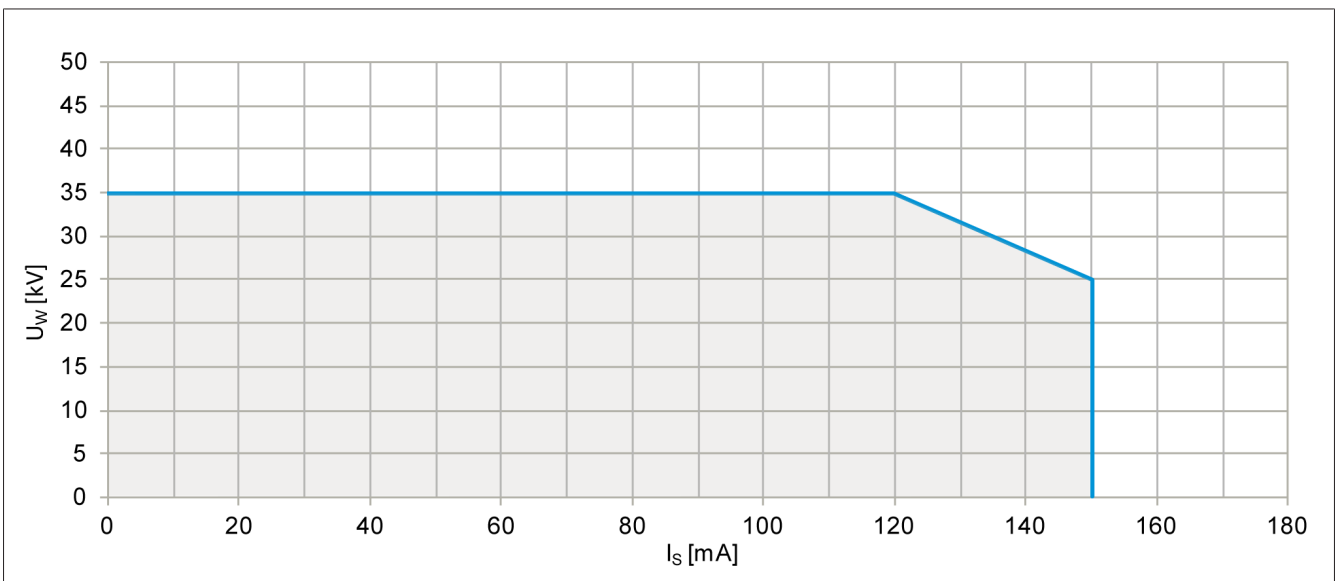
다음의 부하시 탭 절환장치 조합을 사용할 수 있습니다.

- VRS I 701/VRS II 702
- VRS I 1001/VRS II 1002
- VRS I 1301/VRS II 1302
- VRM I 701/VRM II 702
- VRM I 1001/VRM II 1002
- VRM I 1301/VRM II 1302
- VRL I 1301/VRL II 1302
- VRH I 651/VRH II 652
- VRH I 1301/VRH II 1302

이를 위한 탭 권선은 아래와 같이 제공되어야 합니다.



그림 18: 델타 결선 VRS I 701/VRS II 702를 위한 부하시 탭 절환장치 조합 VR III K(a = VRS I 701, b = VRS II 702)

3.2 다중 코스 체인지 오버 선택기가 있는 부하시 탭 절환장치

전압을 극히 미세하게 조정하기 위해서는 아주 많은 수의 작동 위치가 필요합니다. 아주 많은 수의 작동 위치는 다중 코스 태핑 배치를 통해서만 실현될 수 있습니다.

예를 들어, 107개의 작동 위치는 코코스 5탭 권선 1개와 18탭이 있는 탭 권선 1개를 사용함으로써 달성할 수 있습니다.

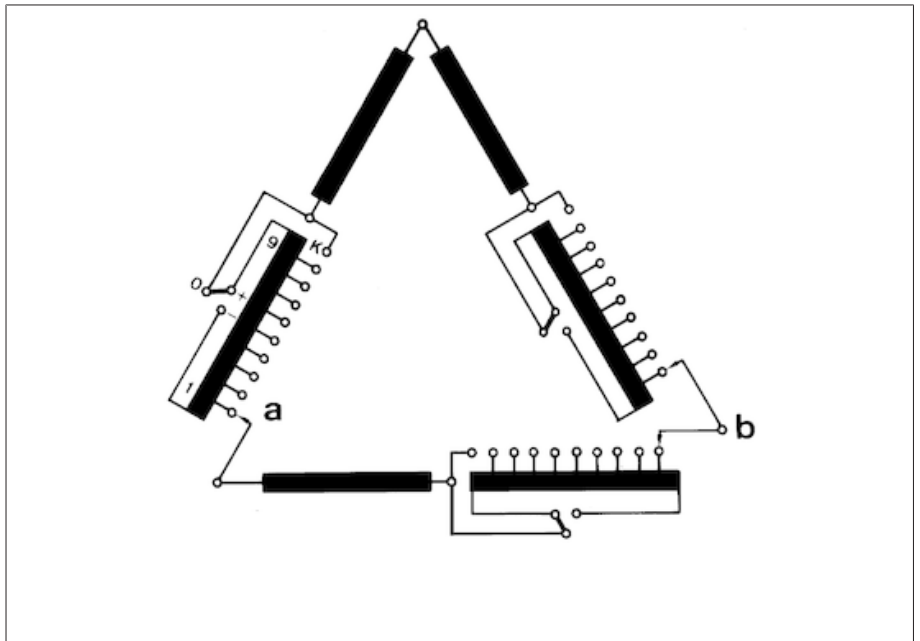
다중 코스 체인지 오버 선택기는 탭 선택기의 양쪽에 부착됩니다.

$U_m = 72.5 \sim$ 최대 300kV용, 2~5개의 코스 탭 연결(탭 선택기 크기 B, C)용, 또는 2개 및 3개의 코스 탭 연결(탭 선택기 크기 D)용 부하시 탭 변환기를 구매할 수 있습니다.

3.3 오픈형 중성점이 있는 Y 연결용 부하시 탭 절환장치

부하시 탭 절환장치에 오픈형 중성점이 있는 경우 **변류기만** 오픈형 중성점에 연결할 수 있습니다. 그렇지 않으면 중성점에서 허용치를 초과하는 과전압이 발생합니다.

i 원자료를 절대 연결해서는 안 됩니다.

3개의 오일 용기 출력 연결(= 오픈형 중성점)	VACUTAP® VRS/VRM/VRL III 700/1000/1300/1600 Y VACUTAP® VRH III 650/1300 Y	
변류기 연결 및 부하시 탭 절환장치 외부 중성점 형성	A) 오일 용기 출력 접점 간 허용된 테스트 전압	
	– 정격 충격 내전압	< 140 kV(1.2/50 μS) ¹⁾
	– 정격 단시간 상용 주파 내전압	1kV(50Hz, 1분)
	B) 오일 용기 출력 접점 간 허용 가능 최대 작동 전압	
1kV(50~60Hz)		
¹⁾ 1.2/50 μs 뇌충격에서 배리스터 응답 전압: > 1.4 kV, 1000 A(8/20 μs) 침투 내전류에서 잔류 전압: < 3 kV, 최대 허용 배리스터의 에너지 부하 < 100 J		

표 20: VACUTAP® VRS/VRM/VRL III 700/1000/1300/1600 Y 및 VACUTAP® VRH III 650/1300 Y용 허용 가능 테스트 전압 및 작동 전압

4 도면

4.1 유형 개요

MASCHINENFABRIK REINHAUSEN GMBH COPYRIGHT RESERVED
 THE REPRODUCTION, DISTRIBUTION AND UTILIZATION OF THIS DOCUMENT AS WELL AS THE COMMUNICATION OF ITS CONTENTS TO OTHERS WITHOUT EXPRESS AUTHORIZATION IS PROHIBITED. OFFENDERS WILL BE HELD LIABLE FOR THE PAYMENT OF DAMAGES. ALL RIGHTS RESERVED IN THE EVENT OF THE GRANT OF A PATENT, UTILITY MODEL OR DESIGN.

DATE	NAME	DOCUMENT NO.
06.05.2021	RAEDLINGER	SED 5097372 001 03
21.05.2021	HAUER	CHANGE NO.
21.05.2021	WANNINGER	1106874
SCALE		1:20

WITHOUT CHANGE-OVER SELECTOR 0

WITH CHANGE-OVER SELECTOR (REVERSING / COARSE CHANGE-OVER SELECTOR) W, G

VRS I 701
 VRS I 1001
 VRS I 1301

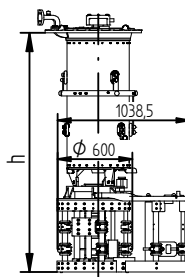
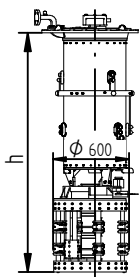

Um [kV]	h [mm]	
	SELECTOR SIZE	
	RC	RD / RDE
72,5	1837	1917
123	1967	2047
170	2097	2177
245	2197	2277
300	2349	2429
362	2452	2532
420	2571	2651

VRS II 702
 VRS II 1002
 VRS II 1302

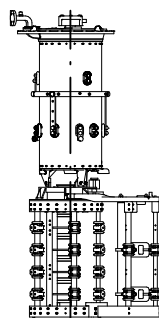
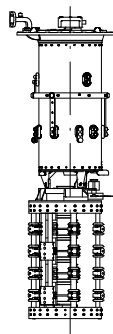

Um [kV]	h [mm]	
	SELECTOR SIZE	
	RC	RD / RDE
72,5	2177	2337
123	2307	2467
170	2437	2597
245	2537	2697
300	2689	2849
362	2792	2952

VRS I 2622

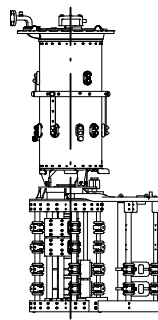
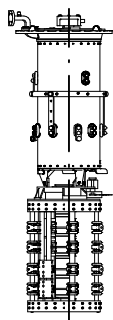

Um [kV]	h [mm]	
	SELECTOR SIZE	
	RC	RD / RDE
72,5	2137	2217
123	2267	2347
170	2397	2477
245	2497	2577
300	2649	2729
362	2752	2832
420	2871	2951

VRS III 700 Y
 VRS III 1000 Y
 VRS III 1300 Y

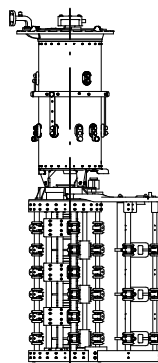
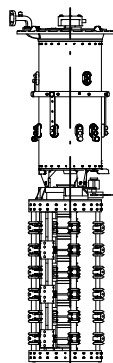

Um [kV]	h [mm]	
	SELECTOR SIZE	
	RC	RD / RDE
72,5	2517	2757
123	2647	2887
170	2777	3017
245	2877	3117

SELECTOR SIZE RC 72,5 kV DISPLAYED

DIMENSION IN mm EXCEPT AS NOTED



ON-LOAD TAP-CHANGER VACUTAP® VR®
 TYPE OVERVIEW VRS - SELECTOR SIZE RC/RD/RDE

SERIAL NUMBER

MATERIAL NUMBER
 100174272E

SHEET
 1/1

MASCHINENFABRIK REINHAUSEN GMBH COPYRIGHT RESERVED
 THE REPRODUCTION, DISTRIBUTION AND UTILIZATION OF THIS DOCUMENT AS WELL AS THE COMMUNICATION OF ITS CONTENTS TO OTHERS WITHOUT EXPRESS AUTHORIZATION IS PROHIBITED. OFFENDERS WILL BE HELD LIABLE FOR THE PAYMENT OF DAMAGES. ALL RIGHTS RESERVED IN THE EVENT OF A PATENT, UTILITY MODEL OR DESIGN.

DATE	NAME	DOCUMENT NO.
07.05.2021	RAEDLINGER	SED 5098990 001 02
21.05.2021	HAUER	CHANGE NO.
21.05.2021	WANNINGER	1106874
SCALE		1:20

VRM I 701
VRM I 1001
VRM I 1301
VRH I 651

WITHOUT CHANGE-OVER SELECTOR	0
------------------------------	---

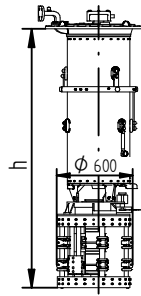

WITH CHANGE-OVER SELECTOR (REVERSING / COARSE CHANGE-OVER SELECTOR)	W, G
---	------

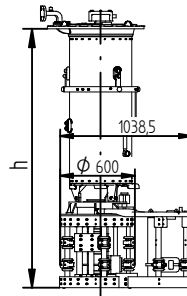

Um [kV]	h [mm]	
	SELECTOR SIZE	
	RC	RD / RDE
72,5	1988	2068
123	2118	2198
170	2248	2328
245	2348	2428
300	2500	2580
362	2603	2683
420	2722	2802

VRM II 702
VRM II 1002
VRM II 1302
VRH II 652

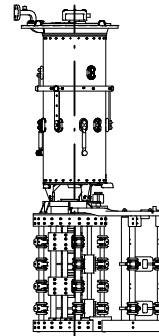
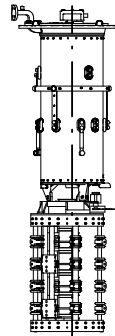

Um [kV]	h [mm]	
	SELECTOR SIZE	
	RC	RD / RDE
72,5	2328	2488
123	2458	2618
170	2588	2748
245	2688	2848
300	2840	3000
362	2943	3103

VRM I 2622

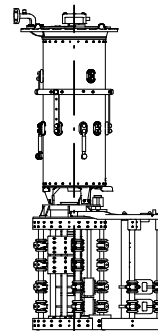
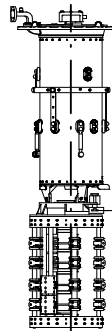

Um [kV]	h [mm]	
	SELECTOR SIZE	
	RC	RD / RDE
72,5	2288	2368
123	2418	2498
170	2548	2628
245	2648	2728
300	2800	2880
362	2903	2983
420	3022	3102

VRM III 700 Y
VRM III 1000 Y
VRM III 1300 Y
VRH III 650 Y

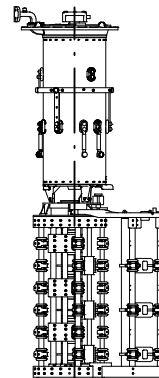
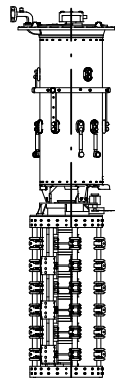

Um [kV]	h [mm]	
	SELECTOR SIZE	
	RC	RD / RDE
72,5	2668	2908
123	2798	3038
170	2928	3168
245	3028	3268

SELECTOR SIZE RC 72,5 kV DISPLAYED

DIMENSION
IN mm
EXCEPT AS
NOTED



ON-LOAD TAP-CHANGER VACUTAP® VR®
TYPE OVERVIEW VRM/H650 - SELECTOR SIZE RC/RD/RDE

SERIAL NUMBER

MATERIAL NUMBER
100174492E

SHEET
1/1

MASCHINENFABRIK REINHAUSEN GMBH COPYRIGHT RESERVED
 THE REPRODUCTION, DISTRIBUTION AND UTILIZATION OF THIS DOCUMENT AS WELL AS THE COMMUNICATION OF ITS CONTENTS TO OTHERS WITHOUT EXPRESS AUTHORIZATION IS PROHIBITED. OFFENDERS WILL BE HELD LIABLE FOR THE PAYMENT OF DAMAGES. ALL RIGHTS RESERVED IN THE EVENT OF THE GRANT OF A PATENT, UTILITY MODEL OR DESIGN.

DATE	NAME	DOCUMENT NO.
DFTR. 26.07.2022	BUTERUS	SED 5099116 001 03
CHKD. 27.07.2022	WREDE	CHANGE NO.
STAND 27.07.2022	KLEYN	116192
		SCALE
		120

WITHOUT CHANGE-OVER SELECTOR 0

WITH CHANGE-OVER SELECTOR (REVERSING / COARSE CHANGE-OVER SELECTOR) W, G

VRL I 1301
VRH I 1301

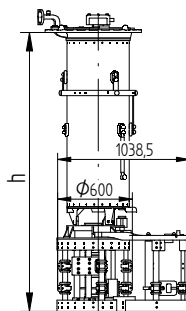
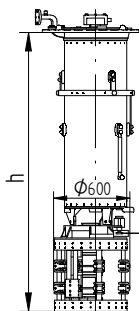

Um [kV]	h [mm]	
	SELECTOR SIZE	
	RC	RD / RDE
72,5	2140	2220
123	2270	2350
170	2400	2480
245	2500	2580
300	2652	2732
362	2755	2835
420	2874	2954

VRL II 1302
VRH II 1302

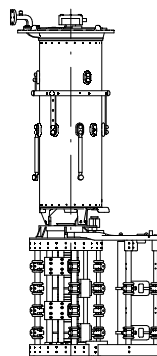
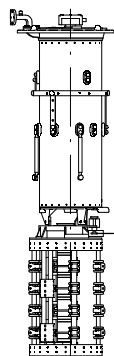

Um [kV]	h [mm]	
	SELECTOR SIZE	
	RC	RD / RDE
72,5	2480	2640
123	2610	2770
170	2740	2900
245	2840	3000
300	2992	3152
362	3095	3255

VRL I 2622
VRH I 2622
VRL I 1601

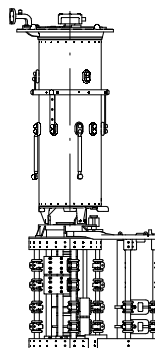
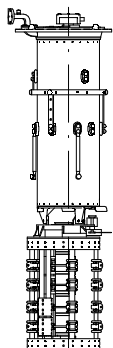

Um [kV]	h [mm]	
	SELECTOR SIZE	
	RC	RD / RDE
72,5	2440	2520
123	2570	2650
170	2700	2780
245	2800	2880
300	2952	3032
362	3055	3135
420	3174	3254

VRL III 1300 Y
VRH III 1300 Y

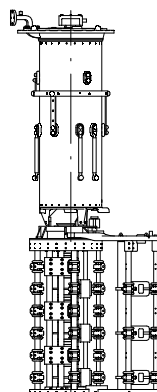
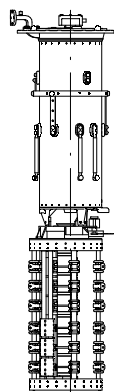

Um [kV]	h [mm]	
	SELECTOR SIZE	
	RC	RD / RDE
72,5	2820	3060
123	2950	3190
170	3080	3320
245	3180	3420

SELECTOR SIZE RC 72,5 kV DISPLAYED

DIMENSION IN mm EXCEPT AS NOTED



ON-LOAD TAP-CHANGER VACUTAP® VR®
 TYPE OVERVIEW VRL/H1300/1601 - SELECTOR SIZE RC/RD/RDE
 DIMENSION DRAWING

SERIAL NUMBER

MATERIAL NUMBER
100174533E

SHEET
1/1

MASCHINENFABRIK REINHAUSEN GMBH COPYRIGHT RESERVED
 THE REPRODUCTION, DISTRIBUTION AND UTILIZATION OF THIS DOCUMENT AS WELL AS THE COMMUNICATION OF ITS CONTENTS TO OTHERS WITHOUT EXPRESS AUTHORIZATION IS PROHIBITED. OFFENDERS WILL BE HELD LIABLE FOR THE PAYMENT OF DAMAGES. ALL RIGHTS RESERVED IN THE EVENT OF THE GRANT OF A PATENT, UTILITY MODEL OR DESIGN.

DATE	NAME	DOCUMENT NO.
10.05.2021	RAEDLINGER	SED 5115917 001 01
21.05.2021	HAUER	CHANGE NO.
21.05.2021	WANNINGER	1106874
SCALE		1:20

VRS I 701
VRS I 1001
VRS I 1301

WITHOUT CHANGE-OVER SELECTOR 0

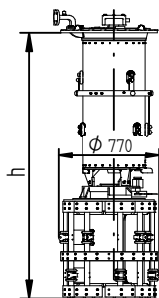

WITH CHANGE-OVER SELECTOR (REVERSING / COARSE CHANGE-OVER SELECTOR) W, G

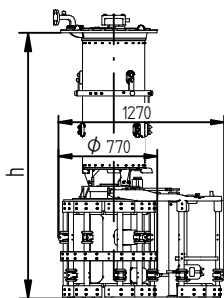

Um [kV]	h [mm]	
	SELECTOR SIZE	
	RE	RF
72,5	2038	-
123	2168	-
170	2298	-
245	2398	-
300	2550	-
362	2653	-
420	2772	-

VRS II 702
VRS II 1002
VRS II 1302

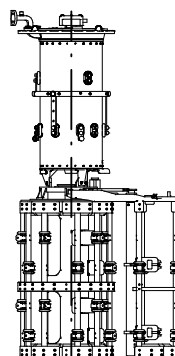
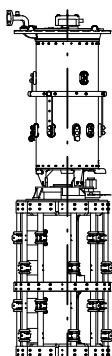

Um [kV]	h [mm]	
	SELECTOR SIZE	
	RE	RF
72,5	2498	2578
123	2628	2708
170	2758	2838
245	2858	2938
300	3010	3090
362	3113	3193

VRS I 2622

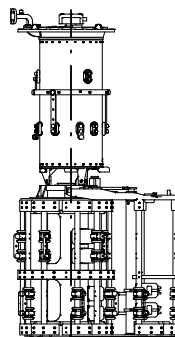
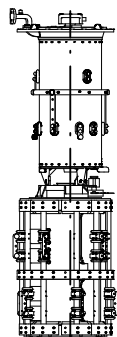

Um [kV]	h [mm]	
	SELECTOR SIZE	
	RE	RF
72,5	2337	-
123	2467	-
170	2597	-
245	2697	-
300	2849	-
362	2952	-
420	3071	-

VRS III 700 Y
VRS III 1000 Y
VRS III 1300 Y

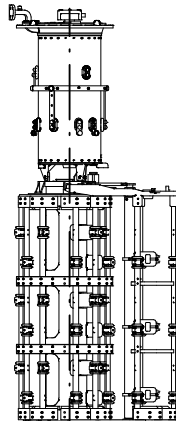
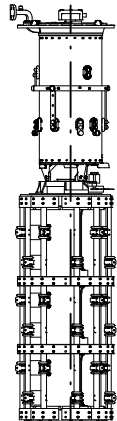

Um [kV]	h [mm]	
	SELECTOR SIZE	
	RE	RF
72,5	3018	3178
123	3148	3308
170	3278	3438
245	3378	3538

RE 72,5 kV DISPLAYED

DIMENSION IN mm EXCEPT AS NOTED



ON-LOAD TAP-CHANGER VACUTAP® VR®
TYPE OVERVIEW VRS - RE/RF

SERIAL NUMBER

MATERIAL NUMBER
100175911E

SHEET
1/1

MASCHINENFABRIK REINHAUSEN GMBH COPYRIGHT RESERVED
 THE REPRODUCTION, DISTRIBUTION AND UTILIZATION OF THIS DOCUMENT AS WELL AS THE COMMUNICATION OF ITS CONTENTS TO OTHERS WITHOUT EXPRESS AUTHORIZATION IS PROHIBITED. OFFENDERS WILL BE HELD LIABLE FOR THE PAYMENT OF DAMAGES. ALL RIGHTS RESERVED IN THE EVENT OF THE GRANT OF A PATENT, UTILITY MODEL OR DESIGN.

DATE	NAME	DOCUMENT NO.
10.05.2021	RAEDLINGER	SED 5117864-001 02
21.05.2021	HAUER	CHANGE NO.
21.05.2021	WANNINGER	1106874
SCALE		1:20

VRM I 701
VRM I 1001
VRM I 1301
VRH I 651

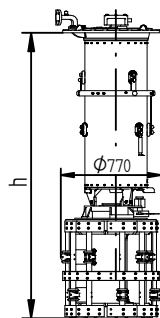

WITHOUT CHANGE-OVER SELECTOR	0
------------------------------	---

WITH CHANGE-OVER SELECTOR (REVERSING / COARSE CHANGE-OVER SELECTOR)	W, G
---	------

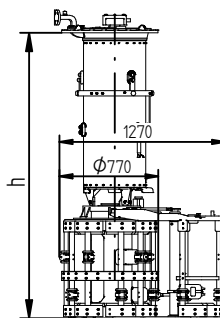

Um [kV]	h [mm]	
	SELECTOR SIZE	
	RE	RF
72,5	2190	-
123	2320	-
170	2450	-
245	2550	-
300	2702	-
362	2805	-
420	2924	-

VRM II 702
VRM II 1002
VRM II 1302
VRH II 652

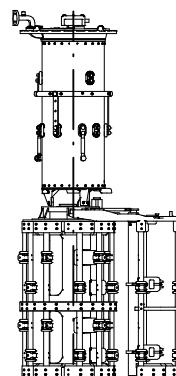
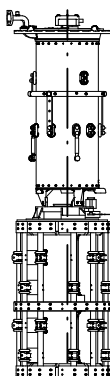

Um [kV]	h [mm]	
	SELECTOR SIZE	
	RE	RF
72,5	2650	2730
123	2780	2860
170	2910	2990
245	3010	3090
300	3162	3242
362	3265	3345

VRM I 2622

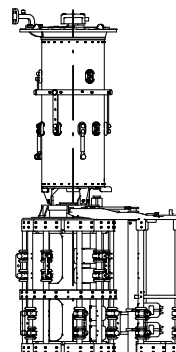
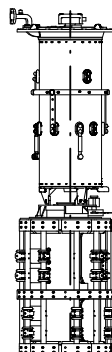

Um [kV]	h [mm]	
	SELECTOR SIZE	
	RE	RF
72,5	2488	-
123	2618	-
170	2748	-
245	2848	-
300	3000	-
362	3103	-
420	3222	-

VRM III 700 Y
VRM III 1000 Y
VRM III 1300 Y
VRH III 650 Y
VRX I 652

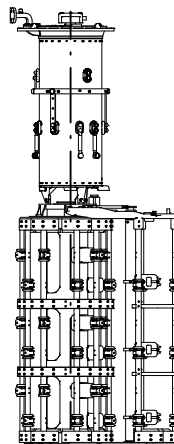
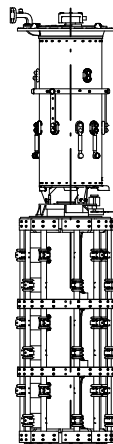

Um [kV]	h [mm]		
	SELECTOR SIZE		
	RE	RF	RES
72,5	3170	3330	3168
123	3300	3460	3298
170	3430	3590	3428
245	3530	3690	3528
300	-	-	3680
362	-	-	3783
420	-	-	3902

RE 72,5 kV DISPLAYED

DIMENSION
IN mm
EXCEPT AS
NOTED



ON-LOAD TAP-CHANGER VACUTAP® VR®
TYPE OVERVIEW VRM/X/H650 - RE/RF/RES

SERIAL NUMBER

MATERIAL NUMBER
100176221E

SHEET
1/1

MASCHINENFABRIK REINHAUSEN GMBH COPYRIGHT RESERVED
 THE REPRODUCTION, DISTRIBUTION AND UTILIZATION OF THIS DOCUMENT AS WELL AS THE COMMUNICATION OF ITS CONTENTS TO OTHERS WITHOUT EXPRESS AUTHORIZATION IS PROHIBITED. OFFENDERS WILL BE HELD LIABLE FOR THE PAYMENT OF DAMAGES. ALL RIGHTS RESERVED IN THE EVENT OF THE GRANT OF A PATENT, UTILITY MODEL OR DESIGN.

DATE	NAME	DOCUMENT NO.
02.08.2022	BUTERUS	SED 519135 001 04
02.08.2022	WREDE	CHANGE NO.
02.08.2022	KLEYN	116192
SCALE		120

DIMENSION
IN mm
EXCEPT AS
NOTED



ON-LOAD TAP-CHANGER VACUTAP® VR®
 TYPE OVERVIEW VRL/VRH/VRX 1300/1601 - RE/RF/RES
 DIMENSION DRAWING

SERIAL NUMBER

-	SHEET
100176263E	1/1

WITHOUT CHANGE-OVER
SELECTOR 0

WITH CHANGE-OVER SELECTOR
(REVERSING / COARSE CHANGE-OVER SELECTOR) W, G

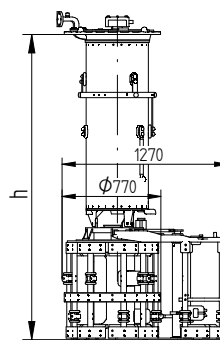
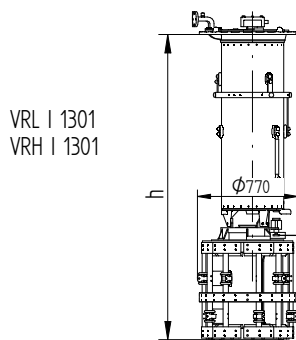

Um [kV]	h [mm]	
	SELECTOR SIZE	
	RE	RF
72,5	2341	-
123	2471	-
170	2601	-
245	2701	-
300	2853	-
362	2956	-
420	3075	-

VRL II 1302
VRH II 1302

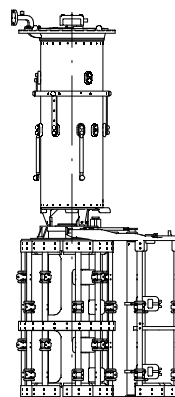
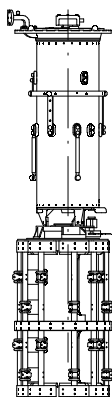

Um [kV]	h [mm]	
	SELECTOR SIZE	
	RE	RF
72,5	2801	2883
123	2931	3013
170	3061	3143
245	3161	3243
300	3313	3395
362	3416	3498

VRL I 2622
VRH I 2622
VRL I 1601

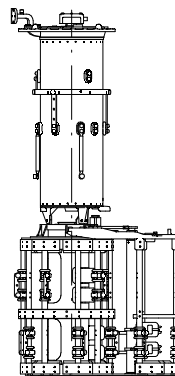
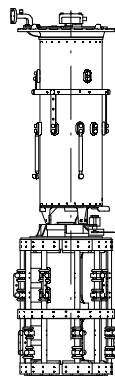

Um [kV]	h [mm]	
	SELECTOR SIZE	
	RE	RF
72,5	2640	-
123	2770	-
170	2900	-
245	3000	-
300	3152	-
362	3255	-
420	3374	-

VRL III 1300 Y
VRH III 1300 Y
VRX I 1302

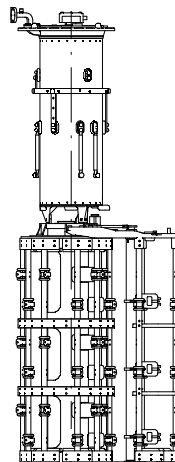
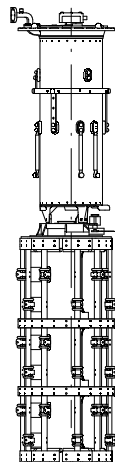

Um [kV]	h [mm]		
	SELECTOR SIZE		
	RE	RF	RES
72,5	3321	3481	3320
123	3451	3611	3450
170	3581	3741	3580
245	3681	3841	3680
300	-	-	3832
362	-	-	3935
420	-	-	4054

SELECTOR SIZE RE 72,5 kV REPRESENTED

© MASCHINENFABRIK REINHAUSEN GMBH 2018
 THE REPRODUCTION, DISTRIBUTION AND UTILIZATION OF THIS DOCUMENT AS WELL AS THE COMMUNICATION OF ITS CONTENTS TO OTHERS WITHOUT EXPRESS AUTHORIZATION IS PROHIBITED. OFFENDERS WILL BE HELD LIABLE FOR THE PAYMENT OF DAMAGES. ALL RIGHTS RESERVED IN THE EVENT OF THE GRANT OF A PATENT, UTILITY MODEL OR DESIGN.

DATE	NAME	DOCUMENT NO.
19.04.2018	RAEDLINGER	SED 5125019 001 02
25.04.2018	HAUER	CHANGE NO.
25.04.2018	PRODASTSCHUK	1087395
DFTR.	SCALE	1:20
CHKD.		
STAND.		

DIMENSION
 IN mm
 EXCEPT AS
 NOTED



ON-LOAD TAP-CHANGER VACUTAP® VR
 TYPE OVERVIEW VRS - B/C/D/DE

SERIAL NUMBER

MATERIAL NUMBER
 100176971E

SHEET
 1/1

WITHOUT CHANGE-OVER
 SELECTOR 0

WITH CHANGE-OVER SELECTOR
 (REVERSING / COARSE CHANGE-OVER SELECTOR) W, G

VRS I 701

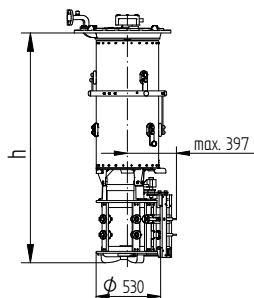
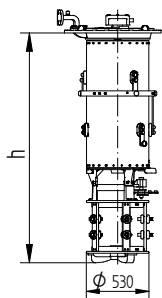

Um [kV]	h [mm]		
	SELECTOR SIZE		
	B	C	D/DE
72,5	1686	1761	1956
123	1816	1891	2086
170	1946	2021	2216
245	2046	2121	2316
300	2198	2273	2468
362	2301	2376	2571
420	2420	2495	2690

VRS I 1001

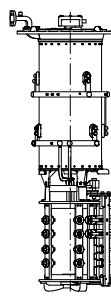
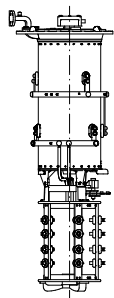

Um [kV]	h [mm]		
	SELECTOR SIZE		
	B	C	D/DE
72,5	1896	1971	2166
123	2026	2101	2296
170	2156	2231	2426
245	2256	2331	2526
300	2408	2483	2678
362	2511	2586	2781
420	2630	2705	2900

VRS I 1301

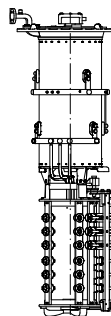
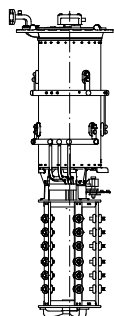

Um [kV]	h [mm]		
	SELECTOR SIZE		
	B	C	D/DE
72,5	2106	2181	2376
123	2236	2311	2506
170	2366	2441	2636
245	2466	2541	2736
300	2618	2693	2888
362	2721	2796	2991
420	2840	2915	3110

VRS II 702

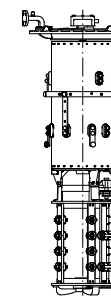
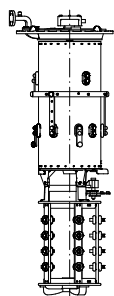

Um [kV]	h [mm]		
	SELECTOR SIZE		
	B	C	D/DE
72,5	1876	2001	2326
123	2006	2131	2456
170	2136	2261	2586
245	2236	2361	2686
300	2388	2513	2838
362	2491	2616	2941

VRS III 700 Y

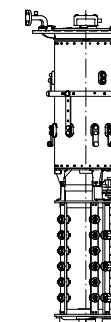
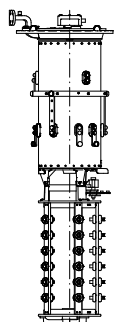

Um [kV]	h [mm]		
	SELECTOR SIZE		
	B	C	D/DE
72,5	2066	2241	2696
123	2196	2371	2826
170	2326	2501	2956
245	2426	2601	3056

SELECTOR SIZE C - 72,5 kV REPRESENTED

© MASCHINENFABRIK REINHAUSEN GMBH 2018
 THE REPRODUCTION, DISTRIBUTION AND UTILIZATION OF THIS DOCUMENT AS WELL AS THE COMMUNICATION OF ITS CONTENTS TO OTHERS WITHOUT EXPRESS AUTHORIZATION IS PROHIBITED. OFFENDERS WILL BE HELD LIABLE FOR THE PAYMENT OF DAMAGES. ALL RIGHTS RESERVED IN THE EVENT OF THE GRANT OF A PATENT, UTILITY MODEL OR DESIGN.

DATE	NAME	DOCUMENT NO.
DFTR. 19.04.2018	RAEDLINGER	SED 5125480 001 02
CHKD. 25.04.2018	HAUER	SCALE
STAND. 25.04.2018	PRODASTSCHUK	120

DIMENSION
 IN mm
 EXCEPT AS
 NOTED



ON-LOAD TAP-CHANGER VACUTAP® VR
 TYPE OVERVIEW VRM - B/C/D/DE

SERIAL NUMBER

MATERIAL NUMBER
 100176981E

SHEET
 1/1

WITHOUT CHANGE-OVER
 SELECTOR 0

WITH CHANGE-OVER SELECTOR
 (REVERSING / COARSE CHANGE-OVER SELECTOR) W, G

VRM I 701

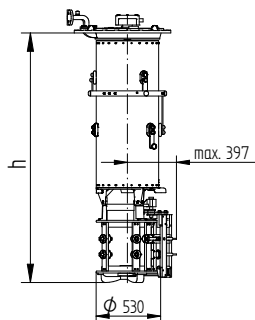
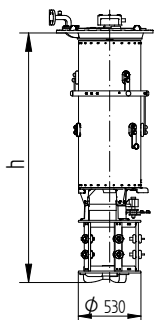

Um [kV]	h [mm]		
	SELECTOR SIZE		
	B	C	D/DE
72,5	1838	1913	2108
123	1968	2043	2238
170	2098	2173	2368
245	2198	2273	2468
300	2350	2425	2620
362	2453	2528	2723
420	2572	2647	2842

VRM I 1001

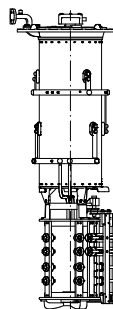
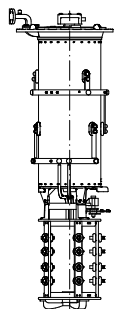

Um [kV]	h [mm]		
	SELECTOR SIZE		
	B	C	D/DE
72,5	2048	2123	2318
123	2178	2253	2448
170	2308	2383	2578
245	2408	2483	2678
300	2560	2635	2830
362	2663	2738	2933
420	2782	2857	3052

VRM I 1301

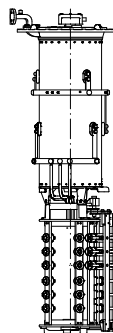
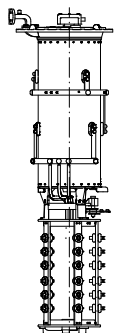

Um [kV]	h [mm]		
	SELECTOR SIZE		
	B	C	D/DE
72,5	2258	2333	2528
123	2388	2463	2658
170	2518	2593	2788
245	2618	2693	2888
300	2770	2845	3040
362	2873	2948	3143
420	2992	3067	3262

VRM II 702

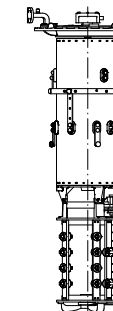
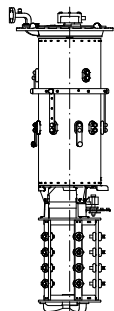

Um [kV]	h [mm]		
	SELECTOR SIZE		
	B	C	D/DE
72,5	2028	2153	2478
123	2158	2283	2608
170	2288	2413	2738
245	2388	2513	2838
300	2540	2665	2990
362	2643	2768	3093

VRM III 700 Y

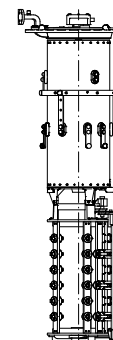
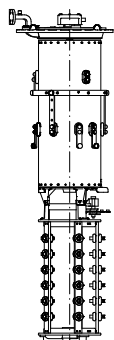

Um [kV]	h [mm]		
	SELECTOR SIZE		
	B	C	D/DE
72,5	2218	2393	2848
123	2348	2523	2978
170	2478	2653	3108
245	2578	2753	3208

SELECTOR SIZE C - 72,5 kV REPRESENTED

© MASCHINENFABRIK REINHAUSEN GMBH 2017
 THE REPRODUCTION, DISTRIBUTION AND UTILIZATION OF THIS DOCUMENT AS WELL AS THE COMMUNICATION OF ITS CONTENTS TO OTHERS WITHOUT EXPRESS AUTHORIZATION IS PROHIBITED. OFFENDERS WILL BE HELD LIABLE FOR THE PAYMENT OF DAMAGES. ALL RIGHTS RESERVED IN THE EVENT OF A PATENT, UTILITY MODEL OR DESIGN.

DATE	NAME	DOCUMENT NO.
DFTR. 13.07.2017	BUTERUS	SED 5552801.001 00
CHKD. 13.07.2017	WREDE	CHANGE NO.
STAND. 14.07.2017	KLEYN	1082427

VRS I 701

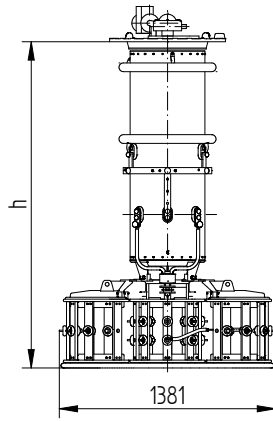

Um [kV]	h [mm]		
	SELECTOR SIZE		
	B	C	D
72,5	1648	1723	1918
123	1778	1853	2048
170	1908	1983	2178
245	2008	2083	2278
300	2160	2235	2430

VRS I 1001

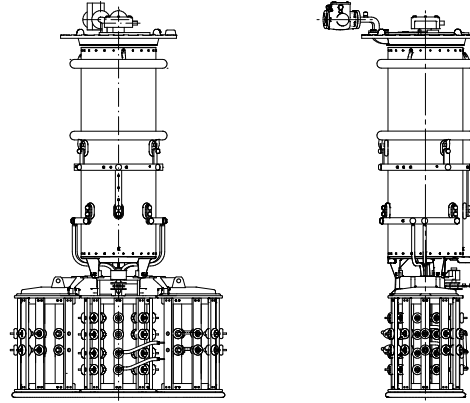

Um [kV]	h [mm]		
	SELECTOR SIZE		
	B	C	D
72,5	1858	1933	2128
123	1988	2063	2258
170	2118	2193	2388
245	2218	2293	2488
300	2370	2445	2640

VRS I 1301

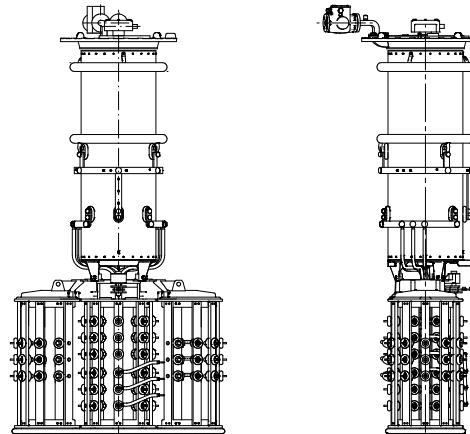

Um [kV]	h [mm]		
	SELECTOR SIZE		
	B	C	D
72,5	2068	2143	2338
123	2198	2273	2468
170	2328	2403	2598
245	2428	2503	2698
300	2580	2655	2850

VRS III 700 Y

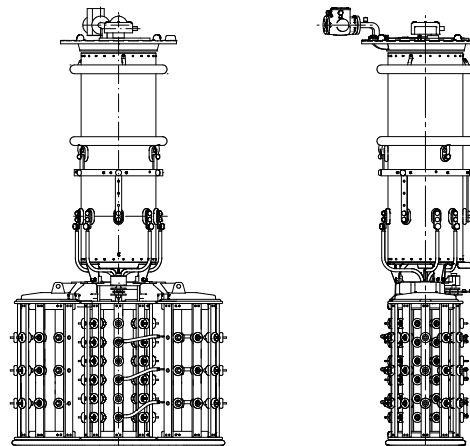

Um [kV]	h [mm]		
	SELECTOR SIZE		
	B	C	D
72,5	2028	2203	2658
123	2158	2333	2788
170	2288	2463	2918
245	2388	2563	3018

DIMENSION
 IN mm
 EXCEPT AS
 NOTED



ON-LOAD TAP-CHANGER VACUTAP® VR
 TYPE OVERVIEW VRS-B/C/D WITH MULTIPLE COARSE CHANGE-OVER SEL
 DIMENSION DRAWING

SERIAL NUMBER

MATERIAL NUMBER
 100208830E

SHEET
 1/1

© MASCHINENFABRIK REINHAUSEN GMBH 2018
 THE REPRODUCTION, DISTRIBUTION AND UTILIZATION OF THIS DOCUMENT AS WELL AS THE COMMUNICATION OF ITS CONTENTS TO OTHERS WITHOUT EXPRESS AUTHORIZATION IS PROHIBITED. OFFENDERS WILL BE HELD LIABLE FOR THE PAYMENT OF DAMAGES. ALL RIGHTS RESERVED IN THE EVENT OF A PATENT, UTILITY MODEL OR DESIGN.

DATE	NAME	DOCUMENT NO.
DFTR. 19.04.2018	RAEDLINGER	SED 6015835 001 00
CHKD. 25.04.2018	HAUER	CHANGE NO.
STAND. 25.04.2018	PRODASTSCHUK	1087395

VRM I 701

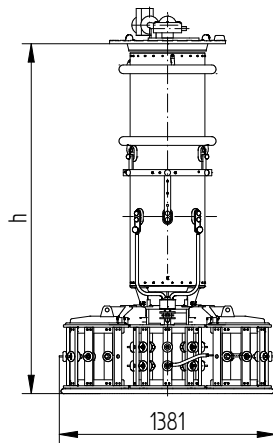

Um [kV]	h [mm]		
	SELECTOR SIZE		
	B	C	D
72,5	1800	1875	2070
123	1930	2005	2200
170	2060	2135	2330
245	2160	2235	2430
300	2312	2387	2582

VRM I 1001

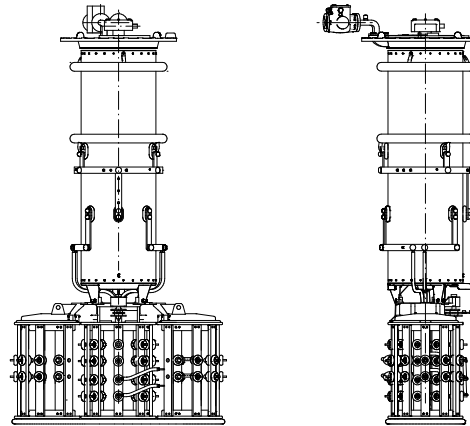

Um [kV]	h [mm]		
	SELECTOR SIZE		
	B	C	D
72,5	2010	2085	2280
123	2140	2215	2410
170	2270	2345	2540
245	2370	2445	2640
300	2522	2597	2792

VRM I 1301

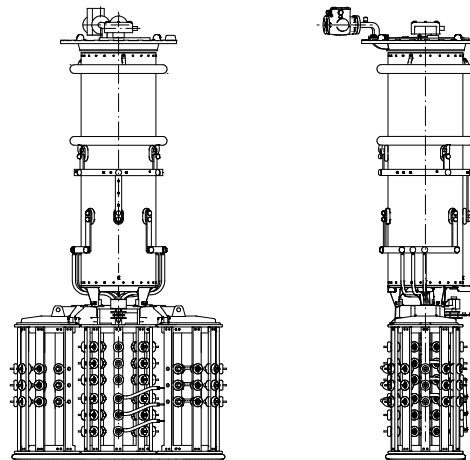

Um [kV]	h [mm]		
	SELECTOR SIZE		
	B	C	D
72,5	2220	2295	2490
123	2350	2425	2620
170	2480	2555	2750
245	2580	2655	2850
300	2732	2807	3002

VRM III 700 Y

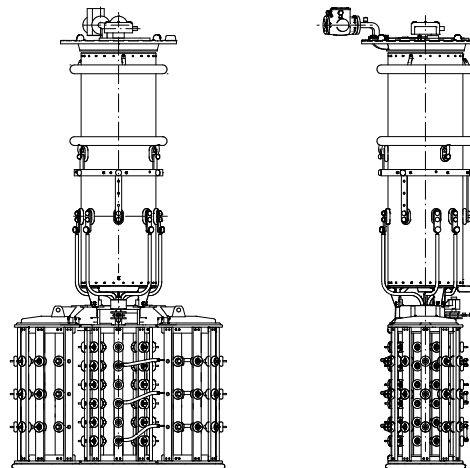

Um [kV]	h [mm]		
	SELECTOR SIZE		
	B	C	D
72,5	2180	2355	2810
123	2310	2485	2940
170	2440	2615	3070
245	2540	2715	3170

SELECTOR SIZE C - 245 kV REPRESENTED

DIMENSION
 IN mm
 EXCEPT AS
 NOTED



ON-LOAD TAP-CHANGER VACUTAP® VR
 VRM - B/C/D WITH MULTIPLE COARSE CHANGE-OVER SELECTOR
 TYPE OVERVIEW

SERIAL NUMBER

MATERIAL NUMBER
 101170700E

SHEET
 1/1

MASCHINENFABRIK REINHAUSEN GMBH COPYRIGHT RESERVED
 THE REPRODUCTION, DISTRIBUTION AND UTILIZATION OF THIS DOCUMENT AS WELL AS THE COMMUNICATION OF ITS CONTENTS TO OTHERS WITHOUT EXPRESS AUTHORIZATION IS
 PROHIBITED. OFFENDERS WILL BE HELD LIABLE FOR THE PAYMENT OF DAMAGES. ALL RIGHTS RESERVED IN THE EVENT OF THE GRANT OF A PATENT, UTILITY MODEL OR DESIGN.

DATE	NAME	DOCUMENT NO.
DFTR. 26.07.2022	BUTERUS	SED 8915332 001 00
CHKD. 27.07.2022	WREDE	CHANGE NO.
STAND 27.07.2022	KLEYN	1116192
		SCALE
		120

DIMENSION
 IN mm
 EXCEPT AS
 NOTED



ON-LOAD TAP-CHANGER VACUTAP® VR®
 TYPE OVERVIEW VRL III 1600 E
 DIMENSION DRAWING

SERIAL NUMBER

MATERIAL NUMBER	SHEET
101715770E	1/1

VRL III 1600 E

WITH CHANGE-OVER SELECTOR (REVERSING /
 COARSE CHANGE-OVER SELECTOR) W, G

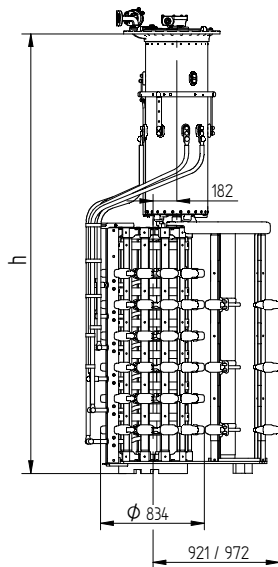

72,5 kV DISPLAYED

Um [kV]	h [mm]
72,5	3372
123	3502
170	3632
245	3732

© MASCHINENFABRIK REINHAUSEN GMBH 2020
 THE REPRODUCTION, DISTRIBUTION AND UTILIZATION OF THIS DOCUMENT AS WELL AS THE COMMUNICATION OF ITS CONTENTS TO OTHERS WITHOUT EXPRESS AUTHORIZATION IS PROHIBITED. OFFENDERS WILL BE HELD LIABLE FOR THE PAYMENT OF DAMAGES. ALL RIGHTS RESERVED IN THE EVENT OF THE GRANT OF A PATENT, UTILITY MODEL OR DESIGN.

WITHOUT CHANGE-OVER SELECTOR 0

WITH CHANGE-OVER SELECTOR
 (REVERSING / COARSE CHANGE-OVER SELECTOR) W, G

VRL I 1801
 VRL I 2001
 VRL I 2401

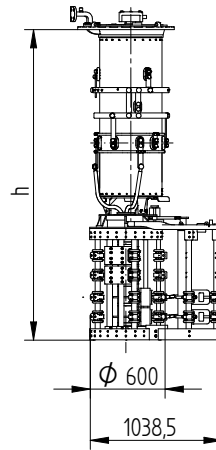
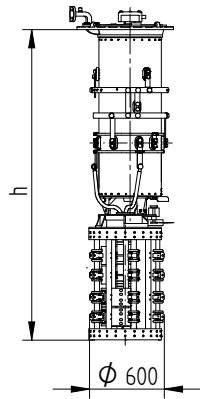

Um [kV]	h [mm]	
	SELECTOR SIZE	
	RC	RD / RDE
72,5	2381	2461
123	2511	2591
170	2641	2721
245	2741	2821
300	2893	2973
362	2996	3076
420	3115	3195

SELECTOR SIZE RC 72,5kV DISPLAYED

VRL I 1801
 VRL I 2001
 VRL I 2401

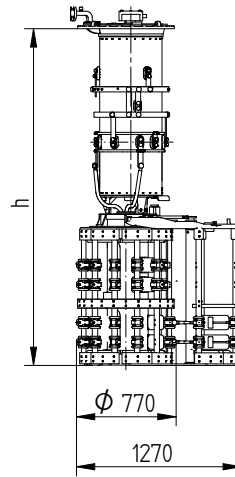
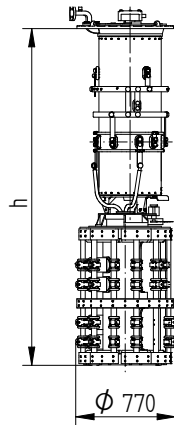

Um [kV]	h [mm]
	SELECTOR SIZE
	RE
72,5	2582
123	2712
170	2842
245	2942
300	3094
362	3197
420	3316

SELECTOR SIZE RE 72,5kV DISPLAYED

DATE	NAME	DOCUMENT NO.
DFTR.	-	SED 8367967 001 01
CHKD.	WREDE	CHANGE NO.
STAND.	-	111654
		SCALE
		1:20

DIMENSION
 IN mm
 EXCEPT AS
 NOTED



ON-LOAD TAP-CHANGER VACUTAP® VR®
 VRL I 1801/2001/2401 - SELECTOR SIZE RC/RD/RDE/RE
 TYPE OVERVIEW

SERIAL NUMBER

MATERIAL NUMBER
 101624790E

SHEET
 1/1

© MASCHINENFABRIK REINHAUSEN GMBH 2020
 THE REPRODUCTION, DISTRIBUTION AND UTILIZATION OF THIS DOCUMENT AS WELL AS THE COMMUNICATION OF ITS CONTENTS TO OTHERS WITHOUT EXPRESS AUTHORIZATION IS PROHIBITED. OFFENDERS WILL BE HELD LIABLE FOR THE PAYMENT OF DAMAGES. ALL RIGHTS RESERVED IN THE EVENT OF THE GRANT OF A PATENT, UTILITY MODEL OR DESIGN.

DATE	NAME	DOCUMENT NO.
05.11.2021	BUTERUS	SED 8367952 001 00
08.11.2021	WREDE	CHANGE NO.
09.11.2021	KLEYN	1109989
DFTR.	SCALE	120
CHKD.		
STAND		

DIMENSION
 IN mm
 EXCEPT AS
 NOTED



ON-LOAD TAP-CHANGER VACUTAP® VR®
 VRL I 2601/3001/3201 - SELECTOR SIZE RC/RD/RDE/RE
 TYPE OVERVIEW

SERIAL NUMBER

MATERIAL NUMBER
 101624760E

SHEET
 1/1

WITHOUT CHANGE-OVER SELECTOR 0

WITH CHANGE-OVER SELECTOR
 (REVERSING / COARSE CHANGE-OVER SELECTOR) W, G

VRL I 2601
 VRL I 3001
 VRL I 3201

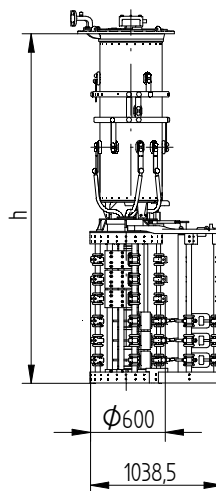
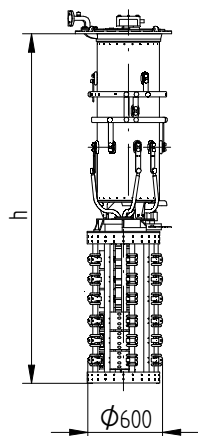

SELECTOR SIZE RC 72,5kV DISPLAYED

Um [kV]	h [mm]	
	SELECTOR SIZE	
	RC	RD / RDE
72,5	2681	2761
123	2811	2891
170	2941	3021
245	3041	3121
300	3193	3273
362	3296	3376
420	3415	3495

VRL I 2601
 VRL I 3001
 VRL I 3201

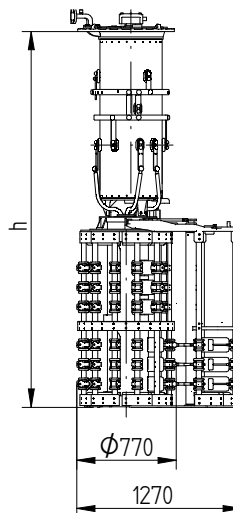
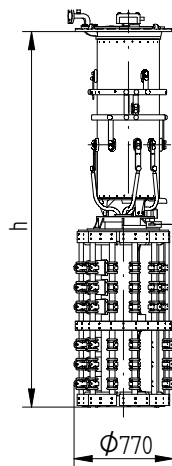

SELECTOR SIZE RE 72,5kV DISPLAYED

Um [kV]	h [mm]
	SELECTOR SIZE
	RE
72,5	2882
123	3012
170	3142
245	3242
300	3394
362	3497
420	3616

4.2 치수도

© MASCHINENFABRIK REINHAUSEN GMBH 2018
 THE REPRODUCTION, DISTRIBUTION AND UTILIZATION OF THIS DOCUMENT AS WELL AS THE COMMUNICATION OF ITS CONTENTS TO OTHERS WITHOUT EXPRESS AUTHORIZATION IS PROHIBITED. OFFENDERS WILL BE HELD LIABLE FOR THE PAYMENT OF DAMAGES. ALL RIGHTS RESERVED IN THE EVENT OF THE GRANT OF A PATENT, UTILITY MODEL OR DESIGN.

DATE	NAME	DOCUMENT NO.
DFTR. 18.01.2018	RAEDLINGER	SED 5142887 001 01
CHKD. 23.01.2018	MENZELS	CHANGE NO.
STANDJ 23.01.2018	PRODASTSCHUK	1085481
		SCALE 1:10

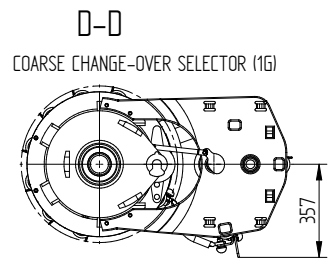
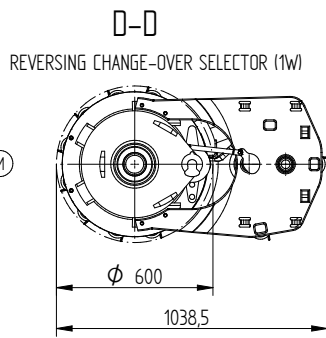
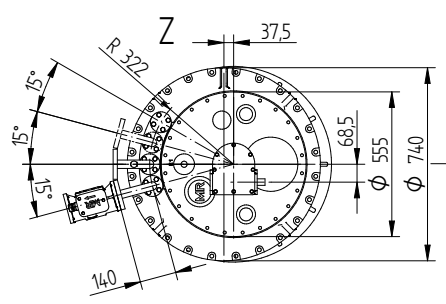
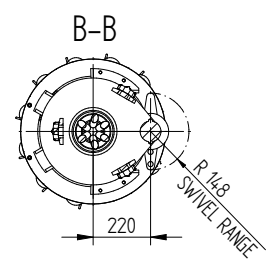
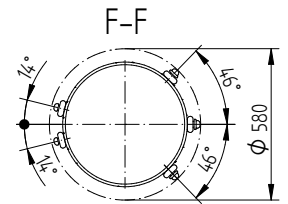
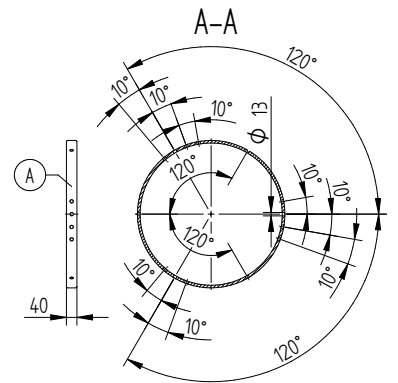
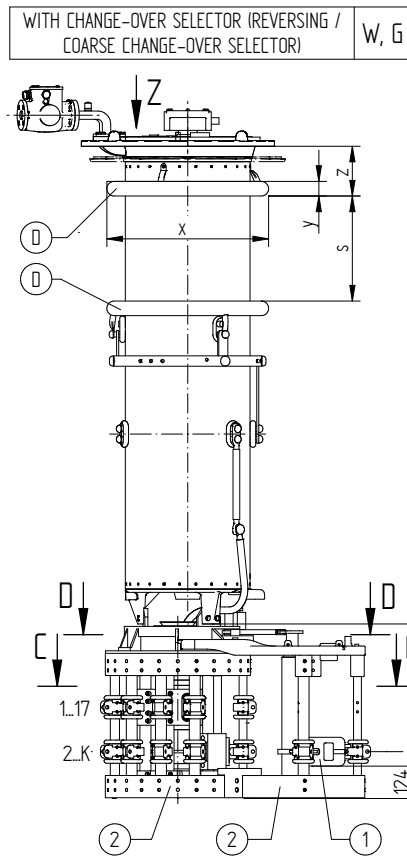
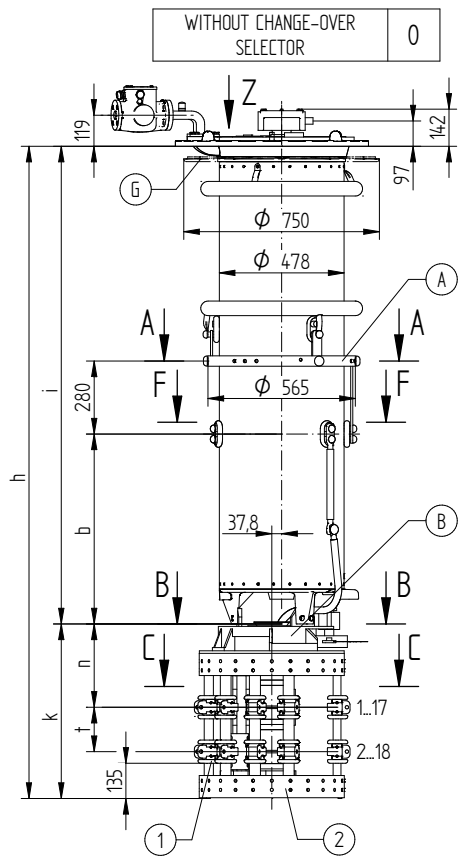

FOR THE TYPE OF OLTC-HEAD REFER TO THE ORDER-SPECIFIC DRAWING OF THE OLTC-HEAD AND DRIVE SHAFTS

- (M) - DRIVE SIDE OF SELECTOR
- (A) - ON-LOAD TAP-CHANGER CURRENT TAKE-OFF TERMINAL
- (B) - IS CONNECTED TO POTENTIAL OF (A)
- (D) - SHIELDING RINGS FOR UM OF 170 kV OR GREATER
- (G) - SUPPORTING FLANGE FOR THE BELL-TYPE TANK INSTALLATION IS OPTIONAL
- (1) - BOTTOM-MOST LIVE PARTS; THESE ARE CONNECTED TO THE POTENTIAL OF THE ASSOCIATED AND/OR WIRED CONNECTION CONTACT
- (2) - SELECTOR BASE IS MADE OF INSULATING MATERIAL

- THE DETAILED CONNECTION DIAGRAM IS BINDING FOR THE DESIGNATION OF THE CONNECTION CONTACTS AND PHASES
- C-C: REFER TO 10009030
- D-D: TYPE WITH CONNECTING LEAD 3W/3G REFER TO 10010019

DIMENSION IN mm EXCEPT AS NOTED



ON-LOAD TAP-CHANGER VACUTAP® VR
 VR S/M/L/H | 651/701/1001/1301 - 72.5...420 kV - RC/RD/RDE
 DIMENSION DRAWING

SERIAL NUMBER	
MATERIAL NUMBER	SHEET
100178561E	1 / 2

© MASCHINENFABRIK REINHAUSEN GMBH 2018
 THE REPRODUCTION, DISTRIBUTION AND UTILIZATION OF THIS DOCUMENT AS WELL AS THE COMMUNICATION OF ITS CONTENTS TO OTHERS WITHOUT EXPRESS AUTHORIZATION IS PROHIBITED. OFFENDERS WILL BE HELD LIABLE FOR THE PAYMENT OF DAMAGES. ALL RIGHTS RESERVED IN THE EVENT OF THE GRANT OF A PATENT, UTILITY MODEL OR DESIGN.

VACUTAP® VRS

SELECTOR SIZE		RC							RD / RDE						
Um [kV]		72,5	123	170	245	300	362	420	72,5	123	170	245	300	362	420
DIMENSIONS [mm]	h	1837	1967	2097	2197	2349	2452	2571	1917	2047	2177	2277	2429	2532	2651
	i	1168	1298	1428	1528	1680	1783	1902	1168	1298	1428	1528	1680	1783	1902
	b	425							425						
	s	-	-	302	402	554	573	692	-	-	302	402	554	573	692
	z	-	-	191	191	191	228	228	-	-	191	191	191	228	228
	x	-	-	∅ 620	∅ 620	∅ 620	∅ 695	∅ 695	-	-	∅ 620	∅ 620	∅ 620	∅ 695	∅ 695
	y	-	-	∅ 56	∅ 56	∅ 56	∅ 100	∅ 100	-	-	∅ 56	∅ 56	∅ 56	∅ 100	∅ 100
	k	669							749						
	n	319							359						
	t	170							210						
q	489							569							
OIL VOLUME [dm³]		160	180	200	220	240	260	280	160	180	200	220	240	260	280
DISPLACEMENT [dm³]		249	269	299	319	349	389	409	250	270	300	320	350	390	410
MAX. WEIGHT [kg]		358	364	377	380	386	393	398	363	369	382	385	391	398	403

VACUTAP® VRM / VRH 651

SELECTOR SIZE		RC							RD / RDE						
Um [kV]		72,5	123	170	245	300	362	420	72,5	123	170	245	300	362	420
DIMENSIONS [mm]	h	1988	2118	2248	2348	2500	2603	2722	2068	2198	2328	2428	2580	2683	2802
	i	1319	1449	1579	1679	1831	1934	2053	1319	1449	1579	1679	1831	1934	2053
	b	576							576						
	s	-	-	302	402	554	573	692	-	-	302	402	554	573	692
	z	-	-	191	191	191	228	228	-	-	191	191	191	228	228
	x	-	-	∅ 620	∅ 620	∅ 620	∅ 695	∅ 695	-	-	∅ 620	∅ 620	∅ 620	∅ 695	∅ 695
	y	-	-	∅ 56	∅ 56	∅ 56	∅ 100	∅ 100	-	-	∅ 56	∅ 56	∅ 56	∅ 100	∅ 100
	k	669							749						
	n	319							359						
	t	170							210						
q	489							569							
OIL VOLUME [dm³]		180	200	230	245	270	285	305	180	200	230	245	270	285	305
DISPLACEMENT [dm³]		269	299	329	349	379	419	439	270	300	330	350	380	420	440
MAX. WEIGHT [kg]		367	373	386	390	395	402	407	372	378	391	395	400	407	412

VACUTAP® VRL / VRH 1301

SELECTOR SIZE		RC							RD / RDE						
Um [kV]		72,5	123	170	245	300	362	420	72,5	123	170	245	300	362	420
DIMENSIONS [mm]	h	2140	2270	2400	2500	2652	2755	2874	2220	2350	2480	2580	2732	2835	2954
	i	1471	1601	1731	1831	1983	2086	2205	1471	1601	1731	1831	1983	2086	2205
	b	728							728						
	s	-	-	302	402	554	573	692	-	-	302	402	554	573	692
	z	-	-	191	191	191	228	228	-	-	191	191	191	228	228
	x	-	-	∅ 620	∅ 620	∅ 620	∅ 695	∅ 695	-	-	∅ 620	∅ 620	∅ 620	∅ 695	∅ 695
	y	-	-	∅ 56	∅ 56	∅ 56	∅ 100	∅ 100	-	-	∅ 56	∅ 56	∅ 56	∅ 100	∅ 100
	k	669							749						
	n	319							359						
	t	170							210						
q	489							569							
OIL VOLUME [dm³]		210	230	250	270	290	310	330	210	230	250	270	290	310	330
DISPLACEMENT [dm³]		299	329	359	379	409	449	469	300	330	360	380	410	450	470
MAX. WEIGHT [kg]		377	383	395	399	405	412	416	382	388	400	404	410	417	421

DATE	NAME	DOCUMENT NO.	SCALE
18.01.2018	RAEDLINGER	SED 5142887 001 01	1:10
23.01.2018	MENZELS	CHANGE NO.	
23.01.2018	PRODASTSEHIK	1085481	

DIMENSION
IN mm
EXCEPT AS
NOTED



ON-LOAD TAP-CHANGER VACUTAP® VR
 VR S/M/L/H | 651/701/1001/1301 - 72,5...420 kV - RC/RD/RDE
 DIMENSION DRAWING

SERIAL NUMBER

MATERIAL NUMBER
100178561E

SHEET
2/2

© MASCHINENFABRIK REINHAUSEN GMBH 2016
 THE REPRODUCTION, DISTRIBUTION AND UTILIZATION OF THIS DOCUMENT AS WELL AS THE COMMUNICATION OF ITS CONTENTS TO OTHERS WITHOUT EXPRESS AUTHORIZATION IS PROHIBITED. OFFENDERS WILL BE HELD LIABLE FOR THE PAYMENT OF DAMAGES. ALL RIGHTS RESERVED IN THE EVENT OF THE GRANT OF A PATENT, UTILITY MODEL OR DESIGN.

DATE	NAME	DOCUMENT NO.
24.10.2016	BUTERUS	SED 5143008 001 00
CHKD. 26.10.2016	WREDE	SCALE
STAND. 26.10.2016	PRODASTSCHUK	1077332

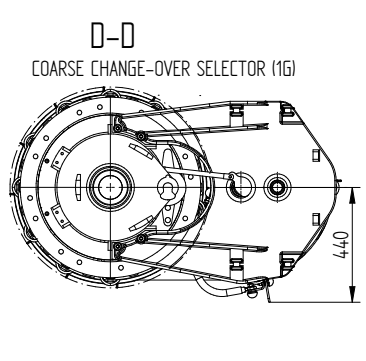
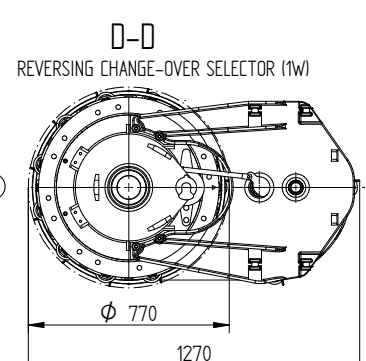
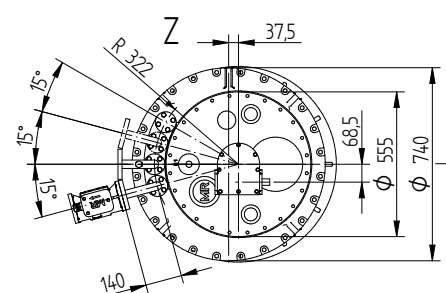
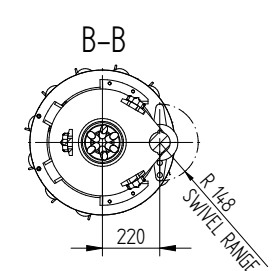
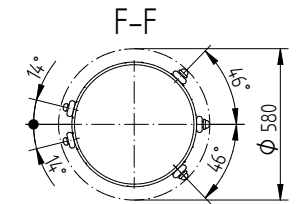
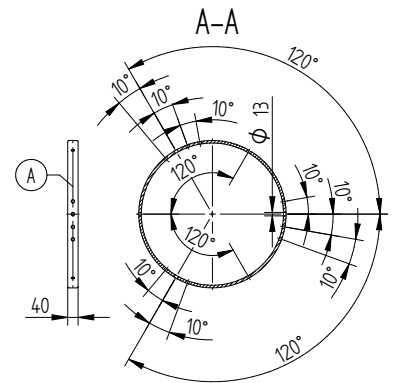
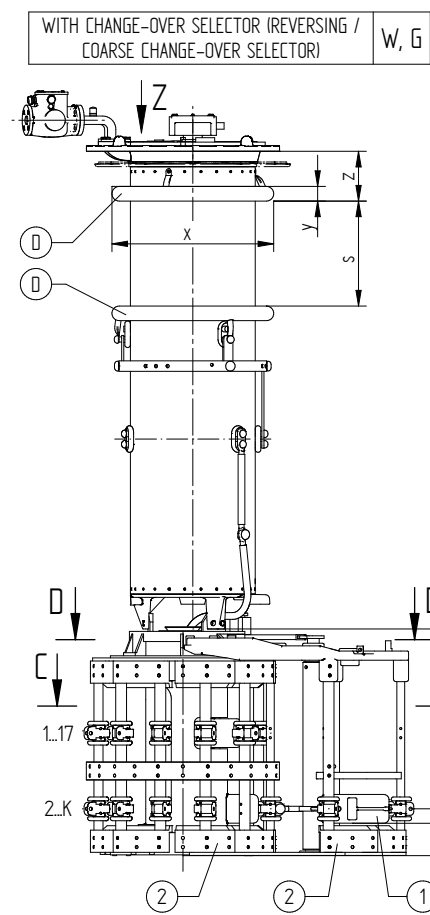
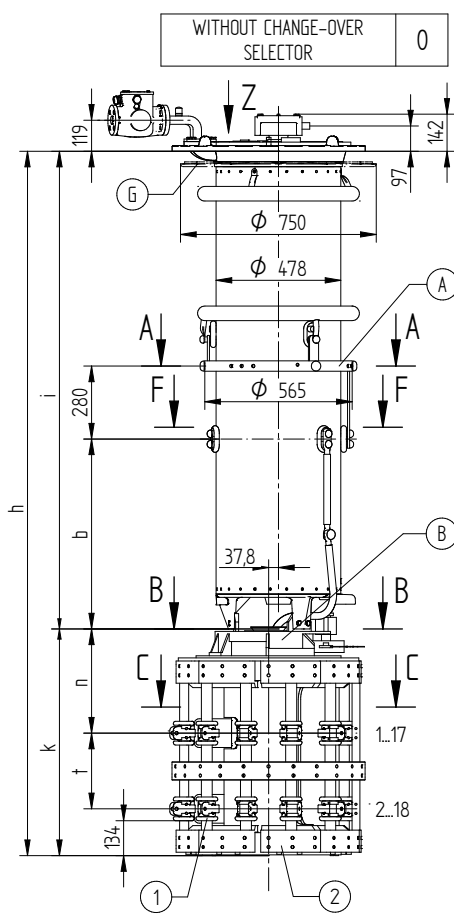

FOR THE TYPE OF OLTC-HEAD REFER TO THE ORDER-SPECIFIC DRAWING OF THE OLTC-HEAD AND DRIVE SHAFTS

- (M) - DRIVE SIDE OF SELECTOR
- (A) - ON-LOAD TAP-CHANGER CURRENT TAKE-OFF TERMINAL
- (B) - IS CONNECTED TO POTENTIAL OF (A)
- (D) - SHIELDING RINGS FOR UM OF 170 KV OR GREATER
- (G) - SUPPORTING FLANGE FOR THE BELL-TYPE TANK INSTALLATION IS OPTIONAL
- (1) - BOTTOM-MOST LIVE PARTS; THESE ARE CONNECTED TO THE POTENTIAL OF THE ASSOCIATED AND/OR WIRED CONNECTION CONTACT
- (2) - SELECTOR BASE IS MADE OF INSULATING MATERIAL

- THE DETAILED CONNECTION DIAGRAM IS BINDING FOR THE DESIGNATION OF THE CONNECTION CONTACTS AND PHASES
- C-C: REFER TO 10016570
- D-D: TYPE WITH CONNECTING LEAD 3W/3G REFER TO 10017264

DIMENSION IN mm EXCEPT AS NOTED



ON-LOAD TAP-CHANGER VACUTAP® VR
 VR S/M/L/H | 651/701/1001/1301 - 72,5...420 kV - RE
 DIMENSION DRAWING

SERIAL NUMBER	
-	
MATERIAL NUMBER	SHEET
100178570E	1/2

© MASCHINENFABRIK REINHAUSEN GMBH 2016
 THE REPRODUCTION, DISTRIBUTION AND UTILIZATION OF THIS DOCUMENT AS WELL AS THE COMMUNICATION OF ITS CONTENTS TO OTHERS WITHOUT EXPRESS AUTHORIZATION IS PROHIBITED. OFFENDERS WILL BE HELD LIABLE FOR THE PAYMENT OF DAMAGES. ALL RIGHTS RESERVED IN THE EVENT OF THE GRANT OF A PATENT, UTILITY MODEL OR DESIGN.

VACUTAP® VRS

SELECTOR SIZE		RE						
Um [kV]		72,5	123	170	245	300	362	420
DIMENSIONS [mm]	h	2038	2168	2298	2398	2550	2653	2772
	i	1168	1298	1428	1528	1680	1783	1902
	b	425						
	s	-	-	302	402	554	573	692
	z	-	-	191	191	191	228	228
	x	-	-	∅ 620	∅ 620	∅ 620	∅ 695	∅ 695
	y	-	-	∅ 56	∅ 56	∅ 56	∅100	∅100
	k	870						
	n	400						
	t	290						
q	690							
OIL CONTENT [dm³]		160	180	200	220	240	260	280
DISPLACEMENT [dm³]		280	300	330	350	380	420	440
MAX. WEIGHT [kg]		419	425	438	441	447	454	459

VACUTAP® VRM / VRH 651

SELECTOR SIZE		RE						
Um [kV]		72,5	123	170	245	300	362	420
DIMENSIONS [mm]	h	2190	2320	2450	2550	2702	2805	2924
	i	1320	1450	1580	1680	1832	1935	2054
	b	576						
	s	-	-	302	402	554	573	692
	z	-	-	191	191	191	228	228
	x	-	-	∅ 620	∅ 620	∅ 620	∅ 695	∅ 695
	y	-	-	∅ 56	∅ 56	∅ 56	∅100	∅100
	k	870						
	n	400						
	t	290						
q	690							
OIL CONTENT [dm³]		180	200	230	245	270	285	305
DISPLACEMENT [dm³]		300	330	360	380	410	450	470
MAX. WEIGHT [kg]		428	434	447	451	456	463	468

VACUTAP® VRL / VRH 1301

SELECTOR SIZE		RE						
Um [kV]		72,5	123	170	245	300	362	420
DIMENSIONS [mm]	h	2341	2471	2601	2701	2853	2956	3075
	i	1471	1601	1731	1831	1983	2086	2205
	b	728						
	s	-	-	302	402	554	573	692
	z	-	-	191	191	191	228	228
	x	-	-	∅ 620	∅ 620	∅ 620	∅ 695	∅ 695
	y	-	-	∅ 56	∅ 56	∅ 56	∅100	∅100
	k	870						
	n	400						
	t	290						
q	690							
OIL CONTENT [dm³]		210	230	250	270	290	310	330
DISPLACEMENT [dm³]		330	360	390	410	440	480	500
MAX. WEIGHT [kg]		438	444	456	460	466	473	477

DATE	NAME	DOCUMENT NO.
DFTR. 24.10.2016	BUTERUS	SED 5143008 001 00
CHKD. 26.10.2016	WREDE	CHANGE NO. -
STAND. 26.10.2016	PRODASTSCHUK	1077332

DIMENSION
IN mm
EXCEPT AS
NOTED



ON-LOAD TAP-CHANGER VACUTAP® VR
VR S/M/L/H | 651/701/1001/1301 - 72,5...420 kV - RE
DIMENSION DRAWING

SERIAL NUMBER

MATERIAL NUMBER
100178570E

SHEET
2/2

MASCHINENFABRIK REINHAUSEN GMBH COPYRIGHT RESERVED
 THE REPRODUCTION, DISTRIBUTION AND UTILIZATION OF THIS DOCUMENT AS WELL AS THE COMMUNICATION OF ITS CONTENTS TO OTHERS WITHOUT EXPRESS AUTHORIZATION IS PROHIBITED. OFFENDERS WILL BE HELD LIABLE FOR THE PAYMENT OF DAMAGES. ALL RIGHTS RESERVED IN THE EVENT OF THE GRANT OF A PATENT, UTILITY MODEL OR DESIGN.

DATE	NAME	DOCUMENT NO.
07.05.2021	RAEDLINGER	SED 5144508_001_02
21.05.2021	HAUER	CHANGE NO.
21.05.2021	WANNINGER	1106874
SCALE		1:10

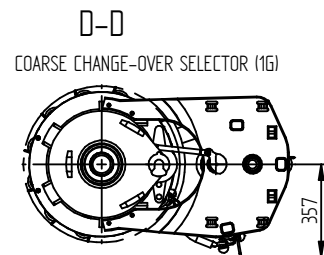
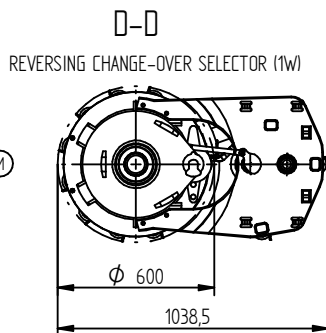
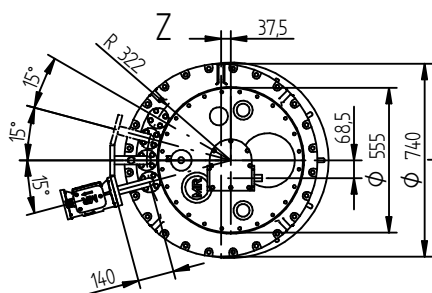
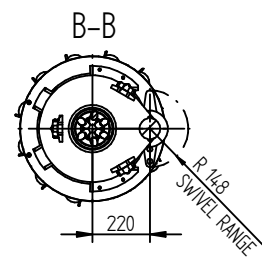
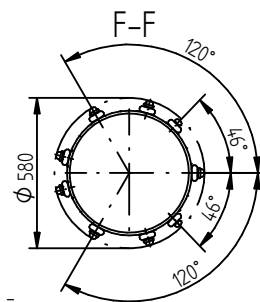
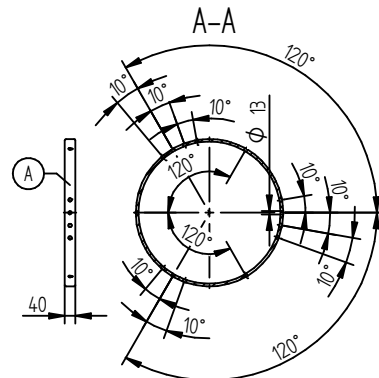
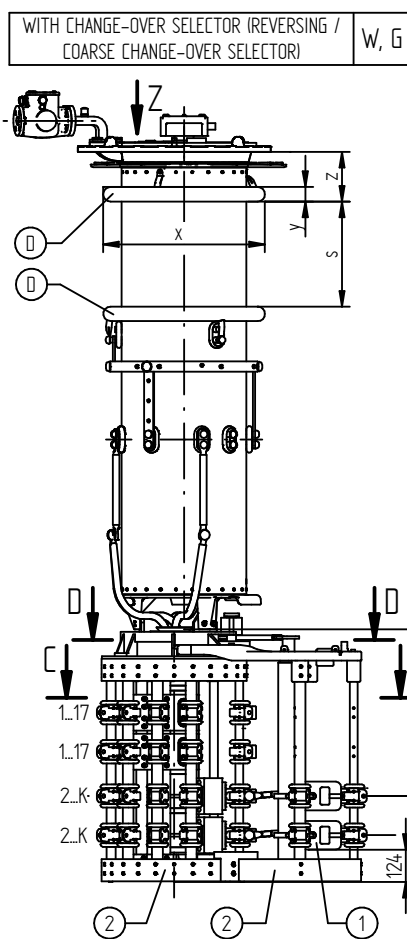
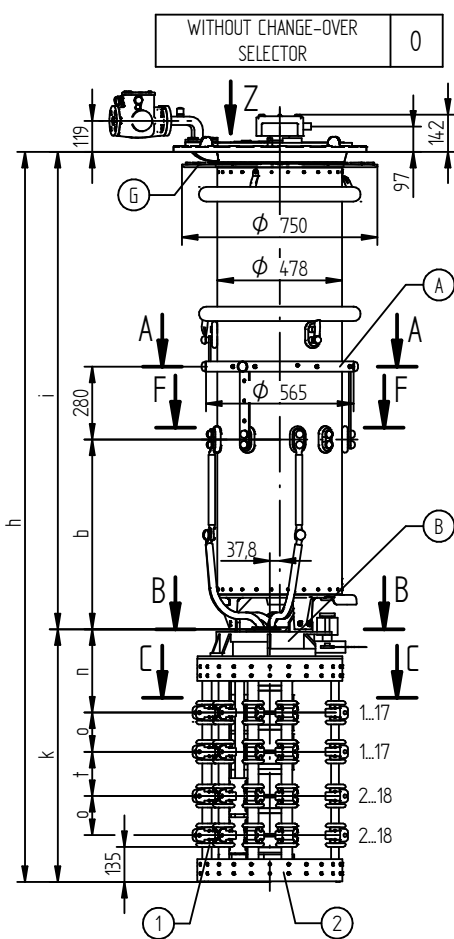

FOR THE TYPE OF OLTC-HEAD REFER TO THE ORDER-SPECIFIC DRAWING OF THE OLTC-HEAD AND DRIVE SHAFTS

- (M) - DRIVE SIDE OF SELECTOR
- (A) - ON-LOAD TAP-CHANGER CURRENT TAKE-OFF TERMINAL
- (B) - IS CONNECTED TO POTENTIAL OF (A)
- (D) - SHIELDING RINGS FOR UM OF 170 KV OR GREATER
- (G) - SUPPORTING FLANGE FOR THE BELL-TYPE TANK INSTALLATION IS OPTIONAL
- (1) - BOTTOM-MOST LIVE PARTS; THESE ARE CONNECTED TO THE POTENTIAL OF THE ASSOCIATED AND/OR WIRED CONNECTION CONTACT
- (2) - SELECTOR BASE IS MADE OF INSULATING MATERIAL

- THE DETAILED CONNECTION DIAGRAM IS BINDING FOR THE DESIGNATION OF THE CONNECTION CONTACTS AND PHASES
- C-C: REFER TO 10009030
- D-D: TYPE WITH CONNECTING LEAD 3W/3G REFER TO 10010019

DIMENSION IN mm EXCEPT AS NOTED



ON-LOAD TAP-CHANGER VACUTAP® VR®
 VRS/M/L/H | 2622-72,5...420-RC/RD/RDE-WITH FORCED CURRENT SPLITTING
 DIMENSION DRAWING

SERIAL NUMBER

MATERIAL NUMBER 100178622E SHEET 1/2

MASCHINENFABRIK REINHAUSEN GMBH COPYRIGHT RESERVED
 THE REPRODUCTION, DISTRIBUTION AND UTILIZATION OF THIS DOCUMENT AS WELL AS THE COMMUNICATION OF ITS CONTENTS TO OTHERS WITHOUT EXPRESS AUTHORIZATION IS PROHIBITED. OFFENDERS WILL BE HELD LIABLE FOR THE PAYMENT OF DAMAGES. ALL RIGHTS RESERVED IN THE EVENT OF A PATENT, UTILITY MODEL OR DESIGN.

DATE	07.05.2021	DOCUMENT NO.	SED 5144508_001_02
DFTR.	RAEDLINGER	NAME	HAUJER
CHKD.	21.05.2021	CHANGE NO.	1106874
STAND	21.05.2021	SCALE	1:10

VACUTAP® VRS

SELECTOR SIZE		RC							RD / RDE						
Um [kV]		72,5	123	170	245	300	362	420	72,5	123	170	245	300	362	420
DIMENSIONS [mm]	h	2137	2267	2397	2497	2649	2752	2871	2217	2347	2477	2577	2729	2832	2951
	i	1168	1298	1428	1528	1680	1783	1902	1168	1298	1428	1528	1680	1783	1902
	b	425							425						
	s	-	-	302	402	554	573	692	-	-	302	402	554	573	692
	z	-	-	191	191	191	228	228	-	-	191	191	191	228	228
	x	-	-	∅ 620	∅ 620	∅ 620	∅ 695	∅ 695	-	-	∅ 620	∅ 620	∅ 620	∅ 695	∅ 695
	y	-	-	∅ 56	∅ 56	∅ 56	∅ 100	∅ 100	-	-	∅ 56	∅ 56	∅ 56	∅ 100	∅ 100
	k	969							1049						
	n	319							359						
	o	150							150						
	t	170							210						
	r	150							150						
q	639							719							
OIL VOLUME [dm³]		155	175	195	215	235	255	275	155	175	195	215	235	255	275
DISPLACEMENT [dm³]		263	283	313	333	363	403	423	265	285	315	335	365	405	425
MAX. WEIGHT [kg]		450	456	469	472	478	485	490	455	461	474	477	483	490	495

VACUTAP® VRM

SELECTOR SIZE		RC							RD / RDE						
Um [kV]		72,5	123	170	245	300	362	420	72,5	123	170	245	300	362	420
DIMENSIONS [mm]	h	2288	2418	2548	2648	2800	2903	3022	2368	2498	2628	2728	2880	2983	3102
	i	1319	1449	1579	1679	1831	1934	2053	1319	1449	1579	1679	1831	1934	2053
	b	576							576						
	s	-	-	302	402	554	573	692	-	-	302	402	554	573	692
	z	-	-	191	191	191	228	228	-	-	191	191	191	228	228
	x	-	-	∅ 620	∅ 620	∅ 620	∅ 695	∅ 695	-	-	∅ 620	∅ 620	∅ 620	∅ 695	∅ 695
	y	-	-	∅ 56	∅ 56	∅ 56	∅ 100	∅ 100	-	-	∅ 56	∅ 56	∅ 56	∅ 100	∅ 100
	k	969							1049						
	n	319							359						
	o	150							150						
	t	170							210						
	r	150							150						
q	639							719							
OIL VOLUME [dm³]		175	195	225	240	265	280	300	175	195	225	240	265	280	300
DISPLACEMENT [dm³]		283	313	343	363	393	433	453	285	315	345	365	395	435	455
MAX. WEIGHT [kg]		466	472	484	488	494	500	505	471	477	489	493	499	505	510

VACUTAP® VRL / VRH

SELECTOR SIZE		RC							RD / RDE						
Um [kV]		72,5	123	170	245	300	362	420	72,5	123	170	245	300	362	420
DIMENSIONS [mm]	h	2440	2570	2700	2800	2952	3055	3174	2520	2650	2780	2880	3032	3135	3254
	i	1471	1601	1731	1831	1983	2086	2205	1471	1601	1731	1831	1983	2086	2205
	b	728							728						
	s	-	-	302	402	554	573	692	-	-	302	402	554	573	692
	z	-	-	191	191	191	228	228	-	-	191	191	191	228	228
	x	-	-	∅ 620	∅ 620	∅ 620	∅ 695	∅ 695	-	-	∅ 620	∅ 620	∅ 620	∅ 695	∅ 695
	y	-	-	∅ 56	∅ 56	∅ 56	∅ 100	∅ 100	-	-	∅ 56	∅ 56	∅ 56	∅ 100	∅ 100
	k	969							1049						
	n	319							359						
	o	150							150						
	t	170							210						
	r	150							150						
q	639							719							
OIL VOLUME [dm³]		205	225	245	265	285	305	325	205	225	245	265	285	305	325
DISPLACEMENT [dm³]		313	343	373	393	423	463	483	315	345	375	395	425	465	485
MAX. WEIGHT [kg]		479	485	497	501	507	514	519	484	490	502	506	512	519	524

DIMENSION IN mm EXCEPT AS NOTED



ON-LOAD TAP-CHANGER VACUTAP® VR®
 VRS/M/L/H | 2622-72,5...420-RC/RD/RDE-WITH FORCED CURRENT SPLITTING
 DIMENSION DRAWING

SERIAL NUMBER

MATERIAL NUMBER 100178622E SHEET 2/2

MASCHINENFABRIK REINHAUSEN GMBH COPYRIGHT RESERVED
 THE REPRODUCTION, DISTRIBUTION AND UTILIZATION OF THIS DOCUMENT AS WELL AS THE COMMUNICATION OF ITS CONTENTS TO OTHERS WITHOUT EXPRESS AUTHORIZATION IS PROHIBITED. OFFENDERS WILL BE HELD LIABLE FOR THE PAYMENT OF DAMAGES. ALL RIGHTS RESERVED IN THE EVENT OF THE GRANT OF A PATENT, UTILITY MODEL OR DESIGN.

DATE	NAME	DOCUMENT NO.
10.05.2021	RAEDLINGER	SED 5144510 001 02
21.05.2021	HAUER	CHANGE NO.
21.05.2021	WANNINGER	1106874
SCALE		1:10

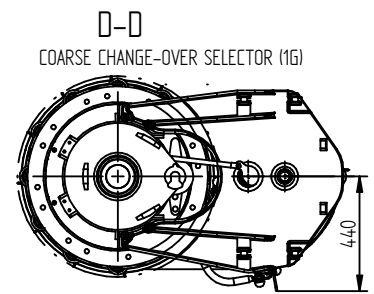
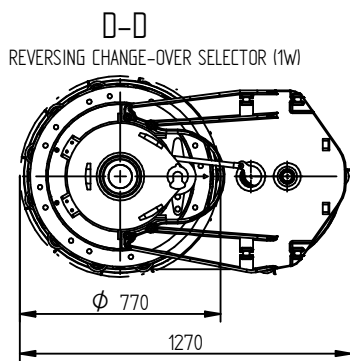
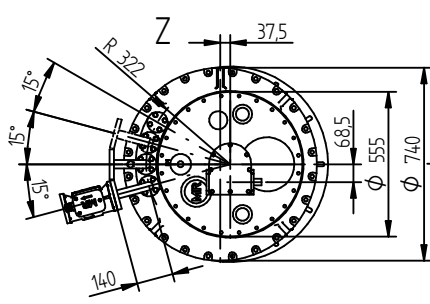
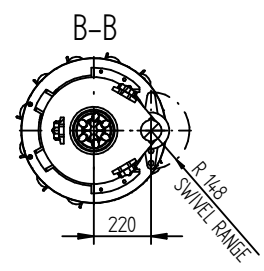
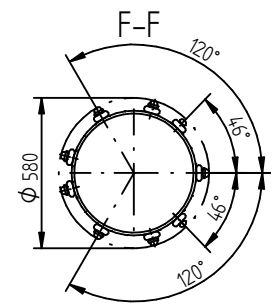
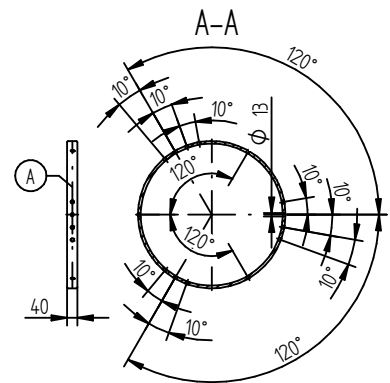
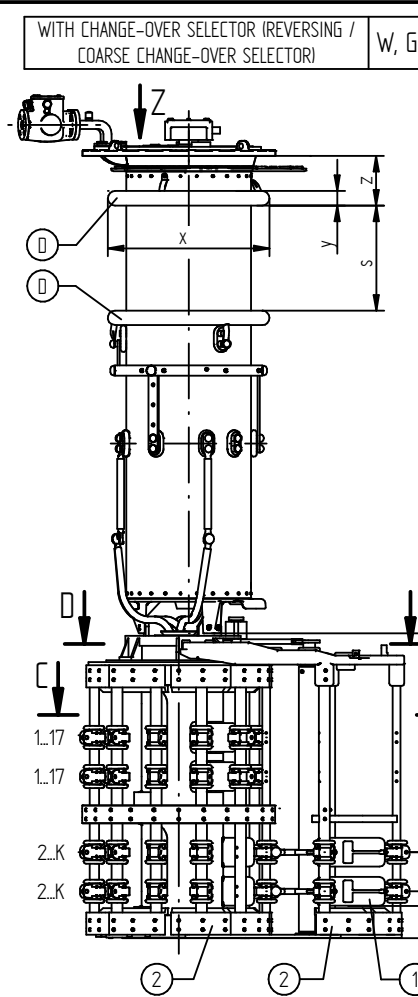
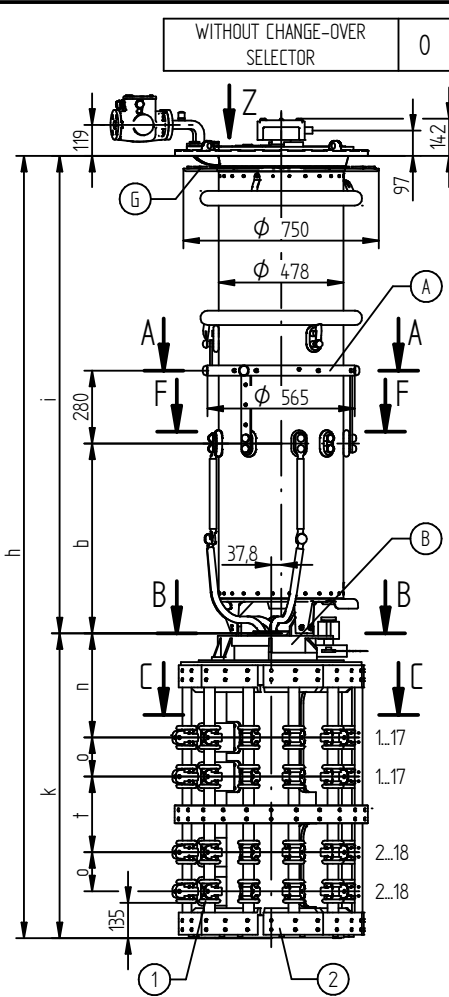

FOR THE TYPE OF OLTC-HEAD REFER TO THE ORDER-SPECIFIC DRAWING OF THE OLTC-HEAD AND DRIVE SHAFTS

- (M) - DRIVE SIDE OF SELECTOR
- (A) - ON-LOAD TAP-CHANGER CURRENT TAKE-OFF TERMINAL
- (B) - IS CONNECTED TO POTENTIAL OF (A)
- (D) - SHIELDING RINGS FOR UM OF 170 KV OR GREATER
- (G) - SUPPORTING FLANGE FOR THE BELL-TYPE TANK INSTALLATION IS OPTIONAL
- (1) - BOTTOM-MOST LIVE PARTS; THESE ARE CONNECTED TO THE POTENTIAL OF THE ASSOCIATED AND/OR WIRED CONNECTION CONTACT
- (2) - SELECTOR BASE IS MADE OF INSULATING MATERIAL

- THE DETAILED CONNECTION DIAGRAM IS BINDING FOR THE DESIGNATION OF THE CONNECTION CONTACTS AND PHASES
- C-C: REFER TO 10016570
- D-D: TYPE WITH CONNECTING LEAD 3W/3G REFER TO 10017264

DIMENSION IN mm EXCEPT AS NOTED



ON-LOAD TAP-CHANGER VACUTAP® VR®
 VRS/M/L/H | 2622-72,5...420 kV-RE-WITH FORCED CURRENT SPLITTING
 DIMENSION DRAWING

SERIAL NUMBER	-
MATERIAL NUMBER	100178631E
SHEET	1/2

MASCHINENFABRIK REINHAUSEN GMBH COPYRIGHT RESERVED
 THE REPRODUCTION, DISTRIBUTION AND UTILIZATION OF THIS DOCUMENT AS WELL AS THE COMMUNICATION OF ITS CONTENTS TO OTHERS WITHOUT EXPRESS AUTHORIZATION IS PROHIBITED. OFFENDERS WILL BE HELD LIABLE FOR THE PAYMENT OF DAMAGES. ALL RIGHTS RESERVED IN THE EVENT OF THE GRANT OF A PATENT, UTILITY MODEL OR DESIGN.

VACUTAP® VRS

SELECTOR SIZE		RE						
Um [kV]		72,5	123	170	245	300	362	420
DIMENSIONS [mm]	h	2337	2467	2597	2697	2849	2952	3071
	i	1168	1298	1428	1528	1680	1783	1902
	b	425						
	s	-	-	302	402	554	573	692
	z	-	-	191	191	191	228	228
	x	-	-	∅ 620	∅ 620	∅ 620	∅ 695	∅ 695
	y	-	-	∅ 56	∅ 56	∅ 56	∅100	∅100
	k	1169						
	n	399						
	o	150						
	t	290						
	r	150						
	q	839						
OIL VOLUME [dm³]		155	175	195	215	235	255	275
DISPLACEMENT [dm³]		298	318	348	368	398	438	458
MAX. WEIGHT [kg]		512	518	531	534	540	547	552

VACUTAP® VRM

SELECTOR SIZE		RE						
Um [kV]		72,5	123	170	245	300	362	420
DIMENSIONS [mm]	h	2488	2618	2748	2848	3000	3103	3222
	i	1319	1449	1579	1679	1831	1934	2053
	b	576						
	s	-	-	302	402	554	573	692
	z	-	-	191	191	191	228	228
	x	-	-	∅ 620	∅ 620	∅ 620	∅ 695	∅ 695
	y	-	-	∅ 56	∅ 56	∅ 56	∅100	∅100
	k	1169						
	n	399						
	o	150						
	t	290						
	r	150						
	q	839						
OIL VOLUME [dm³]		175	195	225	240	265	280	300
DISPLACEMENT [dm³]		318	348	378	398	428	468	488
MAX. WEIGHT [kg]		528	534	546	550	556	562	567

VACUTAP® VRL / VRH

SELECTOR SIZE		RE						
Um [kV]		72,5	123	170	245	300	362	420
DIMENSIONS [mm]	h	2640	2770	2900	3000	3152	3255	3374
	i	1471	1601	1731	1831	1983	2086	2205
	b	728						
	s	-	-	302	402	554	573	692
	z	-	-	191	191	191	228	228
	x	-	-	∅ 620	∅ 620	∅ 620	∅ 695	∅ 695
	y	-	-	∅ 56	∅ 56	∅ 56	∅100	∅100
	k	1169						
	n	399						
	o	150						
	t	290						
	r	150						
	q	839						
OIL VOLUME [dm³]		205	225	245	265	285	305	325
DISPLACEMENT [dm³]		348	378	408	428	458	498	518
MAX. WEIGHT [kg]		541	547	559	563	569	576	581

DATE	NAME	DOCUMENT NO.
10.05.2021	RAEDLINGER	SED 5144510 001 02
21.05.2021	HAUER	SCALE
21.05.2021	WANNINGER	CHANGE NO. 1106874
		1:10

DIMENSION IN mm EXCEPT AS NOTED



ON-LOAD TAP-CHANGER VACUTAP® VR®
 VRS/M/L/H | 2622-72,5...420 kV-RE-WITH FORCED CURRENT SPLITTING
 DIMENSION DRAWING

SERIAL NUMBER

MATERIAL NUMBER 100178631E SHEET 2/2

MASCHINENFABRIK REINHAUSEN GMBH COPYRIGHT RESERVED
 THE REPRODUCTION, DISTRIBUTION AND UTILIZATION OF THIS DOCUMENT AS WELL AS THE COMMUNICATION OF ITS CONTENTS TO OTHERS WITHOUT EXPRESS AUTHORIZATION IS PROHIBITED. OFFENDERS WILL BE HELD LIABLE FOR THE PAYMENT OF DAMAGES. ALL RIGHTS RESERVED IN THE EVENT OF A PATENT, UTILITY MODEL OR DESIGN.

DATE	NAME	DOCUMENT NO.
07.05.2021	RAEDLINGER	SED 5'152467 001 03
21.05.2021	HAUER	CHANGE NO.
21.05.2021	WANNINGER	1106874
SCALE		1:10

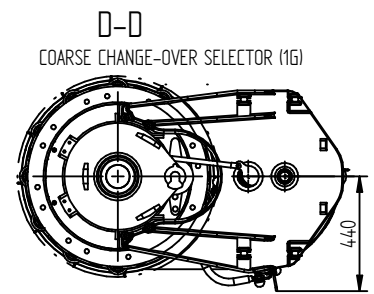
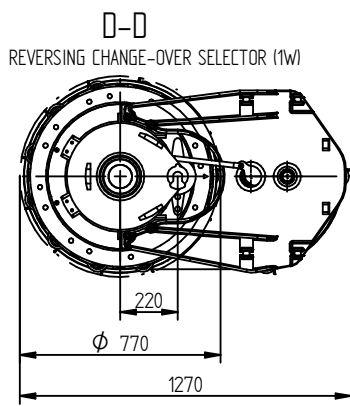
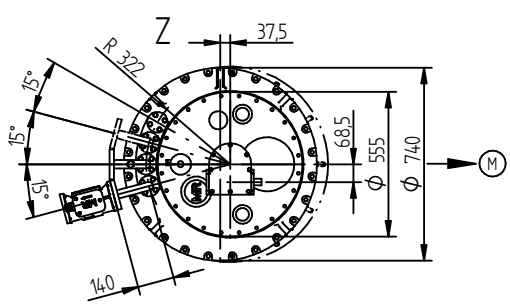
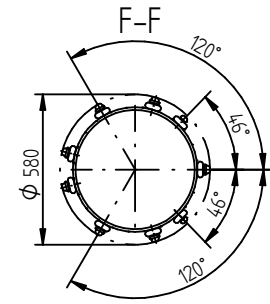
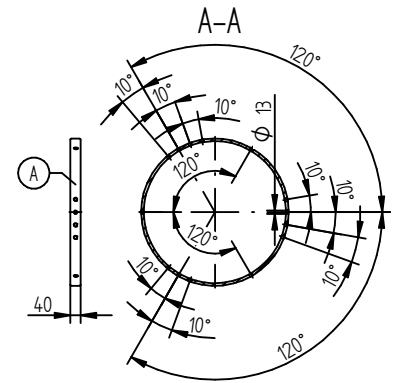
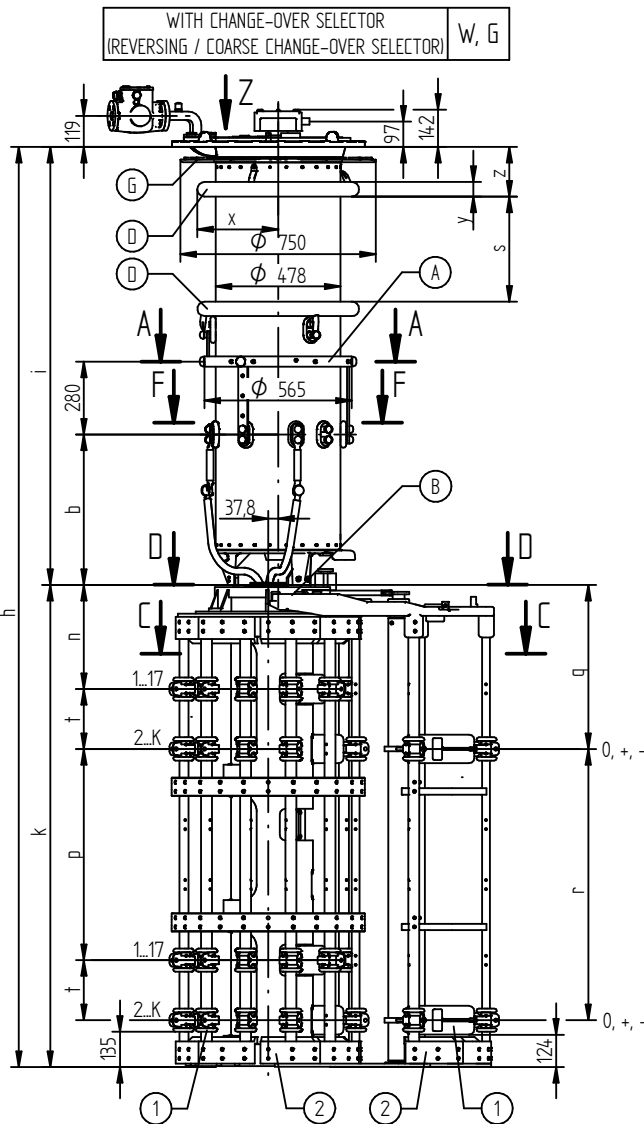

FOR THE TYPE OF OLTC-HEAD REFER TO THE ORDER-SPECIFIC DRAWING OF THE OLTC-HEAD AND DRIVE SHAFTS

- (M) - DRIVE SIDE OF SELECTOR
- (A) - ON-LOAD TAP-CHANGER CURRENT TAKE-OFF TERMINAL
- (B) - IS CONNECTED TO POTENTIAL OF (A)
- (D) - SHIELDING RINGS FOR UM OF 170 KV OR GREATER
- (G) - SUPPORTING FLANGE FOR THE BELL-TYPE TANK INSTALLATION IS OPTIONAL
- (1) - BOTTOM-MOST LIVE PARTS; THESE ARE CONNECTED TO THE POTENTIAL OF THE ASSOCIATED AND/OR WIRED CONNECTION CONTACT
- (2) - SELECTOR BASE IS MADE OF INSULATING MATERIAL

- THE DETAILED CONNECTION DIAGRAM IS BINDING FOR THE DESIGNATION OF THE CONNECTION CONTACTS AND PHASES
- C-C: REFER TO 10016570
- D-D: TYPE WITH CONNECTING LEAD 3W/3G REFER TO 10017264

DIMENSION IN mm EXCEPT AS NOTED



ON-LOAD TAP-CHANGER VACUTAP® VR®
 VRX I 652/1302 - 72,5...420 kV - RES
 DIMENSION DRAWING

SERIAL NUMBER	-
MATERIAL NUMBER	100178673E
SHEET	1/2

MASCHINENFABRIK REINHAUSEN GMBH COPYRIGHT RESERVED
 THE REPRODUCTION, DISTRIBUTION AND UTILIZATION OF THIS DOCUMENT AS WELL AS THE COMMUNICATION OF ITS CONTENTS TO OTHERS WITHOUT EXPRESS AUTHORIZATION IS PROHIBITED. OFFENDERS WILL BE HELD LIABLE FOR THE PAYMENT OF DAMAGES. ALL RIGHTS RESERVED IN THE EVENT OF THE GRANT OF A PATENT, UTILITY MODEL OR DESIGN.

VACUTAP® VRX | 652

SELECTOR SIZE		RES						
Um [kV]		72,5	123	170	245	300	362	420
DIMENSIONS [mm]	h	3168	3298	3428	3528	3680	3783	3902
	i	1319	1449	1579	1679	1831	1934	2053
	b	576						
	s	-	-	302	402	554	573	692
	z	-	-	191	191	191	228	228
	x	-	-	∅ 620	∅ 620	∅ 620	∅ 695	∅ 695
	y	-	-	∅ 56	∅ 56	∅ 56	∅ 100	∅ 100
	k	1849						
	n	399						
	t	230						
	p	810						
	r	1040						
	q	629						
OIL VOLUME [dm³]		175	195	225	240	265	280	300
DISPLACEMENT [dm³]		460	490	520	540	570	610	630
MAX. WEIGHT [kg]		609	615	627	631	637	643	648

VACUTAP® VRX | 1302

SELECTOR SIZE		RES						
Um [kV]		72,5	123	170	245	300	362	420
DIMENSIONS [mm]	h	3320	3450	3580	3680	3832	3935	4054
	i	1471	1601	1731	1831	1983	2086	2205
	b	728						
	s	-	-	302	402	554	573	692
	z	-	-	191	191	191	228	228
	x	-	-	∅ 620	∅ 620	∅ 620	∅ 695	∅ 695
	y	-	-	∅ 56	∅ 56	∅ 56	∅ 100	∅ 100
	k	1849						
	n	399						
	t	230						
	p	810						
	r	1040						
	q	629						
OIL VOLUME [dm³]		205	225	245	265	285	305	325
DISPLACEMENT [dm³]		490	520	550	570	600	640	660
MAX. WEIGHT [kg]		622	628	640	644	650	657	662

DATE	NAME	DOCUMENT NO.
07.05.2021	RAEDLINGER	SED 5152467 001 03
21.05.2021	HAUER	CHANGE NO.
21.05.2021	WANNINGER	1106874
SCALE	1:10	

DIMENSION
IN mm
EXCEPT AS
NOTED



ON-LOAD TAP-CHANGER VACUTAP® VR®
VRX | 652/1302 - 72,5...420 kV - RES
DIMENSION DRAWING

SERIAL NUMBER

-	
MATERIAL NUMBER	SHEET
100178673E	2/2

© MASCHINENFABRIK REINHAUSEN GMBH 2018
 THE REPRODUCTION, DISTRIBUTION AND UTILIZATION OF THIS DOCUMENT AS WELL AS THE COMMUNICATION OF ITS CONTENTS TO OTHERS WITHOUT EXPRESS AUTHORIZATION IS PROHIBITED. OFFENDERS WILL BE HELD LIABLE FOR THE PAYMENT OF DAMAGES. ALL RIGHTS RESERVED IN THE EVENT OF THE GRANT OF A PATENT, UTILITY MODEL OR DESIGN.

DATE	NAME	DOCUMENT NO.
DFTR. 18.01.2018	RAEDLINGER	SED 5144363 001 01
CHKD. 23.01.2018	MENZELS	CHANGE NO.
STANDJ 23.01.2018	PRODASTSCHUK	1085481
		SCALE
		1:10

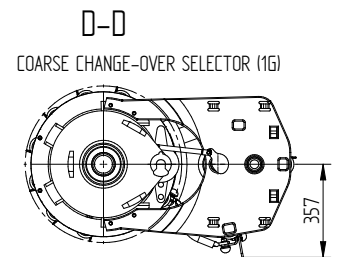
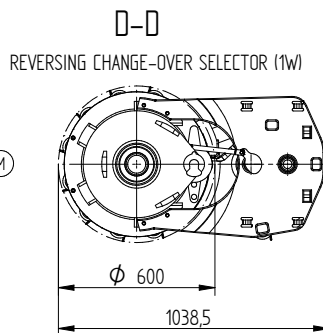
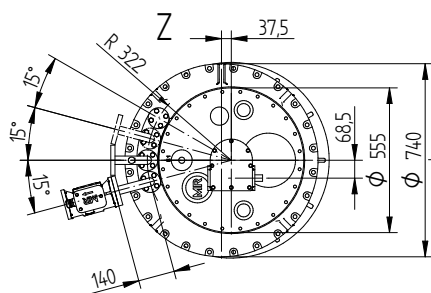
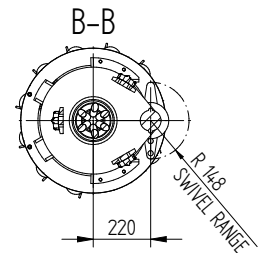
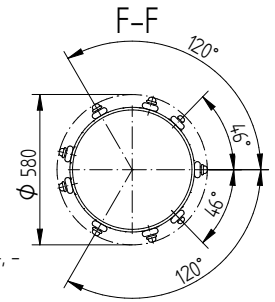
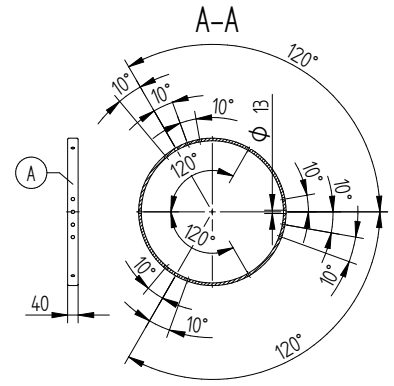
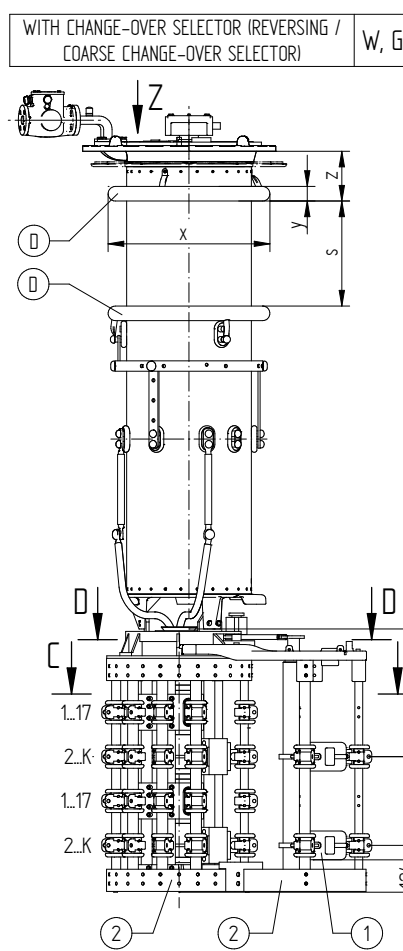
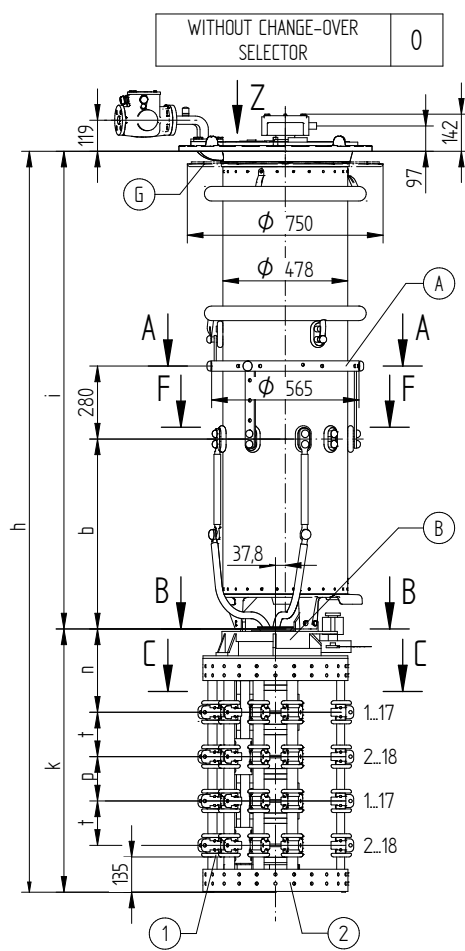

FOR THE TYPE OF OLTC-HEAD REFER TO THE ORDER-SPECIFIC DRAWING OF THE OLTC-HEAD AND DRIVE SHAFTS

- (M) - DRIVE SIDE OF SELECTOR
- (A) - ON-LOAD TAP-CHANGER CURRENT TAKE-OFF TERMINAL
- (B) - IS CONNECTED TO POTENTIAL OF (A)
- (D) - SHIELDING RINGS FOR UM OF 170 kV OR GREATER
- (G) - SUPPORTING FLANGE FOR THE BELL-TYPE TANK INSTALLATION IS OPTIONAL
- (1) - BOTTOM-MOST LIVE PARTS; THESE ARE CONNECTED TO THE POTENTIAL OF THE ASSOCIATED AND/OR WIRED CONNECTION CONTACT
- (2) - SELECTOR BASE IS MADE OF INSULATING MATERIAL

- THE DETAILED CONNECTION DIAGRAM IS BINDING FOR THE DESIGNATION OF THE CONNECTION CONTACTS AND PHASES
- C-C: REFER TO 10009030
- D-D: TYPE WITH CONNECTING LEAD 3W/3G REFER TO 10010019

DIMENSION
IN mm
EXCEPT AS
NOTED



ON-LOAD TAP-CHANGER VACUTAP® VR
 VR S/M/L/H II 652/702/1002/1302 - 72.5...362 kV - RC/RD/RDE
 DIMENSION DRAWING

SERIAL NUMBER

MATERIAL NUMBER
100178591E

SHEET
1/2

© MASCHINENFABRIK REINHAUSEN GMBH 2018
 THE REPRODUCTION, DISTRIBUTION AND UTILIZATION OF THIS DOCUMENT AS WELL AS THE COMMUNICATION OF ITS CONTENTS TO OTHERS WITHOUT EXPRESS AUTHORIZATION IS PROHIBITED. OFFENDERS WILL BE HELD LIABLE FOR THE PAYMENT OF DAMAGES. ALL RIGHTS RESERVED IN THE EVENT OF THE GRANT OF A PATENT, UTILITY MODEL OR DESIGN.

DATE	NAME	DOCUMENT NO.
18.01.2018	RAEDLINGER	SED 5144363 001 01
23.01.2018	MENZELS	CHANGE NO.
23.01.2018	PRODASTSCHUK	1085481
DFTR.	SCALE	1:10

VACUTAP® VRS

SELECTOR SIZE	RC						RD / RDE						
Um [kV]	72,5	123	170	245	300	362	72,5	123	170	245	300	362	
DIMENSIONS [mm]	h	2177	2307	2437	2537	2689	2792	2337	2467	2597	2697	2849	2952
	i	1168	1298	1428	1528	1680	1783	1168	1298	1428	1528	1680	1783
	b	425						425					
	s	-	-	302	402	554	573	-	-	302	402	554	573
	z	-	-	191	191	191	228	-	-	191	191	191	228
	x	-	-	∅ 620	∅ 620	∅ 620	∅ 695	-	-	∅ 620	∅ 620	∅ 620	∅ 695
	y	-	-	∅ 56	∅ 56	∅ 56	∅ 100	-	-	∅ 56	∅ 56	∅ 56	∅ 100
	k	1009						1169					
	n	319						359					
	t	170						210					
	p	170						210					
	r	340						420					
	q	489						569					
OIL VOLUME [dm³]	155	175	195	215	235	255	155	175	195	215	235	255	
DISPLACEMENT [dm³]	263	283	313	333	363	403	266	286	316	336	366	406	
MAX. WEIGHT [kg]	434	440	453	456	462	469	442	448	461	464	470	477	

VACUTAP® VRM / VRH 652

SELECTOR SIZE	RC						RD / RDE						
Um [kV]	72,5	123	170	245	300	362	72,5	123	170	245	300	362	
DIMENSIONS [mm]	h	2328	2458	2588	2688	2840	2943	2488	2618	2748	2848	3000	3103
	i	1319	1449	1579	1679	1831	1934	1319	1449	1579	1679	1831	1934
	b	576						576					
	s	-	-	302	402	554	573	-	-	302	402	554	573
	z	-	-	191	191	191	228	-	-	191	191	191	228
	x	-	-	∅ 620	∅ 620	∅ 620	∅ 695	-	-	∅ 620	∅ 620	∅ 620	∅ 695
	y	-	-	∅ 56	∅ 56	∅ 56	∅ 100	-	-	∅ 56	∅ 56	∅ 56	∅ 100
	k	1009						1169					
	n	319						359					
	t	170						210					
	p	170						210					
	r	340						420					
	q	489						569					
OIL VOLUME [dm³]	175	195	225	240	265	280	175	195	225	240	265	280	
DISPLACEMENT [dm³]	283	313	343	363	393	433	286	316	346	366	396	436	
MAX. WEIGHT [kg]	450	456	468	472	478	484	458	464	476	480	486	492	

VACUTAP® VRL / VRH 1302

SELECTOR SIZE	RC						RD / RDE						
Um [kV]	72,5	123	170	245	300	362	72,5	123	170	245	300	362	
DIMENSIONS [mm]	h	2480	2610	2740	2840	2992	3095	2640	2770	2900	3000	3152	3255
	i	1471	1601	1731	1831	1983	2086	1471	1601	1731	1831	1983	2086
	b	728						728					
	s	-	-	302	402	554	573	-	-	302	402	554	573
	z	-	-	191	191	191	228	-	-	191	191	191	228
	x	-	-	∅ 620	∅ 620	∅ 620	∅ 695	-	-	∅ 620	∅ 620	∅ 620	∅ 695
	y	-	-	∅ 56	∅ 56	∅ 56	∅ 100	-	-	∅ 56	∅ 56	∅ 56	∅ 100
	k	1009						1169					
	n	319						359					
	t	170						210					
	p	170						210					
	r	340						420					
	q	489						569					
OIL VOLUME [dm³]	205	225	245	265	285	305	205	225	245	265	285	305	
DISPLACEMENT [dm³]	313	343	373	393	423	463	316	346	376	396	426	466	
MAX. WEIGHT [kg]	463	469	481	485	491	498	471	477	489	493	499	506	

DIMENSION
IN mm
EXCEPT AS
NOTED



ON-LOAD TAP-CHANGER VACUTAP® VR
 VR S/M/L/H II 652/702/1002/1302 - 72,5...362 kV - RC/RD/RDE
 DIMENSION DRAWING

SERIAL NUMBER

MATERIAL NUMBER
100178591E

SHEET
2/2

© MASCHINENFABRIK REINHAUSEN GMBH 2016
 THE REPRODUCTION, DISTRIBUTION AND UTILIZATION OF THIS DOCUMENT AS WELL AS THE COMMUNICATION OF ITS CONTENTS TO OTHERS WITHOUT EXPRESS AUTHORIZATION IS PROHIBITED. OFFENDERS WILL BE HELD LIABLE FOR THE PAYMENT OF DAMAGES. ALL RIGHTS RESERVED IN THE EVENT OF THE GRANT OF A PATENT, UTILITY MODEL OR DESIGN.

DATE	NAME	DOCUMENT NO.
24.10.2016	BUTERUS	SED 5144498 001 00
CHKD. 26.10.2016	WREDE	CHANGE NO.
STAND. 26.10.2016	PRODASTSCHUK	1077332
		SCALE
		-

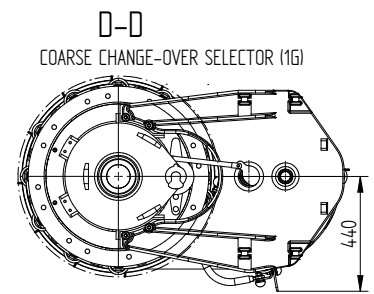
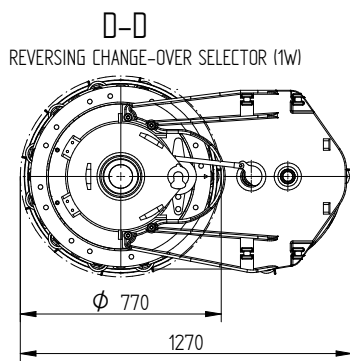
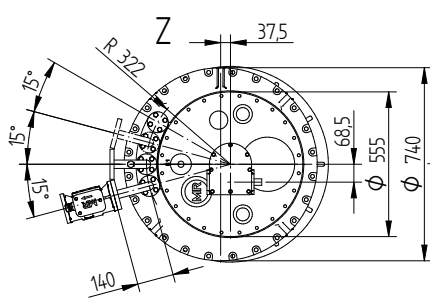
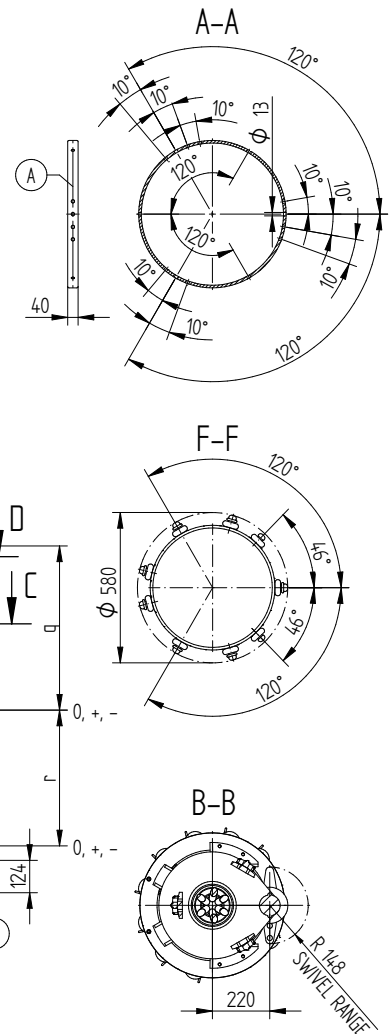
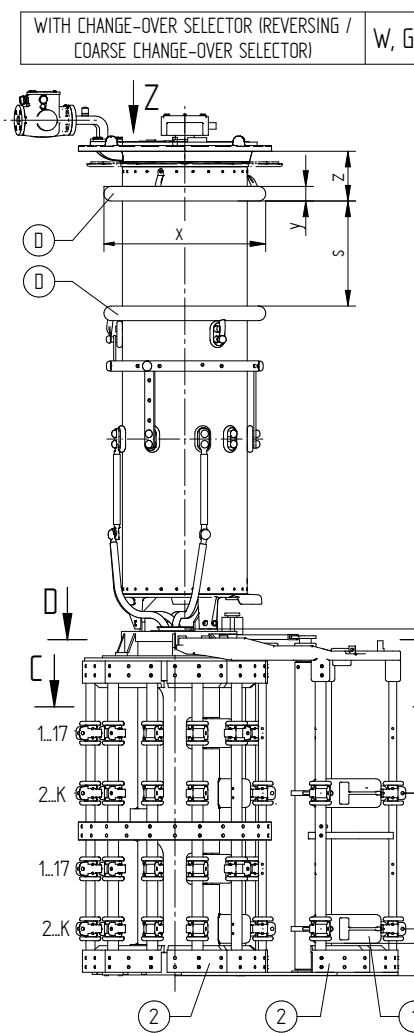
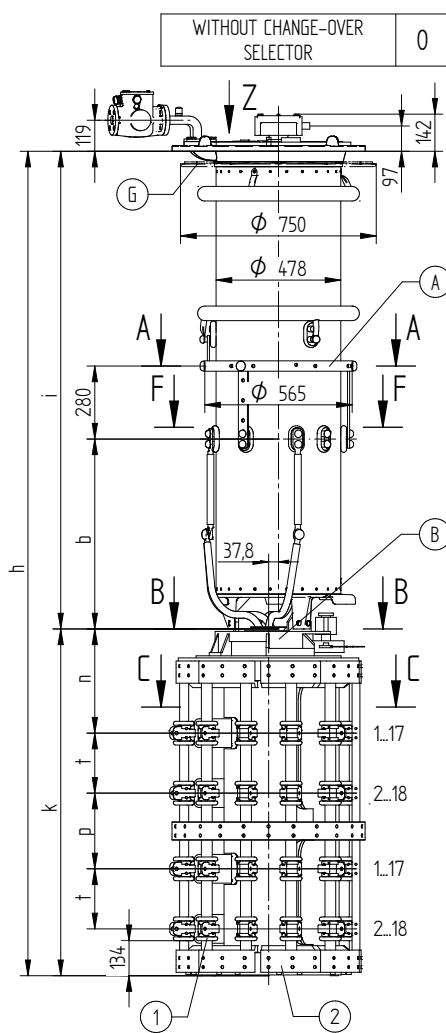

FOR THE TYPE OF OLTC-HEAD REFER TO THE ORDER-SPECIFIC DRAWING OF THE OLTC-HEAD AND DRIVE SHAFTS

- (M) - DRIVE SIDE OF SELECTOR
- (A) - ON-LOAD TAP-CHANGER CURRENT TAKE-OFF TERMINAL
- (B) - IS CONNECTED TO POTENTIAL OF (A)
- (D) - SHIELDING RINGS FOR UM OF 170 KV OR GREATER
- (G) - SUPPORTING FLANGE FOR THE BELL-TYPE TANK INSTALLATION IS OPTIONAL
- (1) - BOTTOM-MOST LIVE PARTS; THESE ARE CONNECTED TO THE POTENTIAL OF THE ASSOCIATED AND/OR WIRED CONNECTION CONTACT
- (2) - SELECTOR BASE IS MADE OF INSULATING MATERIAL

- THE DETAILED CONNECTION DIAGRAM IS BINDING FOR THE DESIGNATION OF THE CONNECTION CONTACTS AND PHASES
 - C-C: REFER TO 10016570
 - D-D: TYPE WITH CONNECTING LEAD 3W/3G REFER TO 10017264

DIMENSION IN mm EXCEPT AS NOTED



ON-LOAD TAP-CHANGER VACUTAP® VR
 VR S/M/L/H II 652/702/1002/1302 - 72,5...362 kV - RE/RF
 DIMENSION DRAWING

SERIAL NUMBER	
-	
MATERIAL NUMBER	SHEET
100178600E	1/2

VACUTAP® VRS

SELECTOR SIZE		RE						RF					
Um [kV]		72,5	123	170	245	300	362	72,5	123	170	245	300	362
DIMENSIONS [mm]	h	2498	2628	2758	2858	3010	3113	2578	2708	2838	2938	3090	3193
	i	1168	1298	1428	1528	1680	1783	1168	1298	1428	1528	1680	1783
	b	425						425					
	s	-	-	302	402	554	573	-	-	302	402	554	573
	z	-	-	191	191	191	228	-	-	191	191	191	228
	x	-	-	∅ 620	∅ 620	∅ 620	∅ 695	-	-	∅ 620	∅ 620	∅ 620	∅ 695
	y	-	-	∅ 56	∅ 56	∅ 56	∅100	-	-	∅ 56	∅ 56	∅ 56	∅100
	k	1330						1410					
	n	400						400					
	t	230						230					
	p	290						370					
	r	520						600					
q	630						630						
OIL CONTENT [dm³]		155	175	195	215	235	255	155	175	195	215	235	255
DISPLACEMENT [dm³]		302	322	352	372	402	442	305	325	355	375	405	445
MAX. WEIGHT [kg]		512	518	531	534	540	547	519	525	538	541	547	554

VACUTAP® VRM / VRH 652

SELECTOR SIZE		RE						RF					
Um [kV]		72,5	123	170	245	300	362	72,5	123	170	245	300	362
DIMENSIONS [mm]	h	2650	2780	2910	3010	3162	3265	2730	2860	2990	3090	3242	3345
	i	1320	1450	1580	1680	1832	1935	1320	1450	1580	1680	1832	1935
	b	576						576					
	s	-	-	302	402	554	573	-	-	302	402	554	573
	z	-	-	191	191	191	228	-	-	191	191	191	228
	x	-	-	∅ 620	∅ 620	∅ 620	∅ 695	-	-	∅ 620	∅ 620	∅ 620	∅ 695
	y	-	-	∅ 56	∅ 56	∅ 56	∅100	-	-	∅ 56	∅ 56	∅ 56	∅100
	k	1330						1410					
	n	400						400					
	t	230						230					
	p	290						370					
	r	520						600					
q	630						630						
OIL CONTENT [dm³]		175	195	225	240	265	280	175	195	225	240	265	280
DISPLACEMENT [dm³]		322	352	382	402	432	472	325	355	385	405	435	475
MAX. WEIGHT [kg]		528	534	546	550	556	562	535	541	553	557	563	569

VACUTAP® VRL / VRH 1302

SELECTOR SIZE		RE						RF					
Um [kV]		72,5	123	170	245	300	362	72,5	123	170	245	300	362
DIMENSIONS [mm]	h	2801	2931	3061	3161	3313	3416	2881	3011	3141	3241	3393	3496
	i	1471	1601	1731	1831	1983	2086	1471	1601	1731	1831	1983	2086
	b	728						728					
	s	-	-	302	402	554	573	-	-	302	402	554	573
	z	-	-	191	191	191	228	-	-	191	191	191	228
	x	-	-	∅ 620	∅ 620	∅ 620	∅ 695	-	-	∅ 620	∅ 620	∅ 620	∅ 695
	y	-	-	∅ 56	∅ 56	∅ 56	∅100	-	-	∅ 56	∅ 56	∅ 56	∅100
	k	1330						1410					
	n	400						400					
	t	230						230					
	p	290						370					
	r	520						600					
q	630						630						
OIL CONTENT [dm³]		205	225	245	265	285	305	205	225	245	265	285	305
DISPLACEMENT [dm³]		352	382	412	432	462	502	355	385	415	435	465	505
MAX. WEIGHT [kg]		541	547	559	563	569	576	548	554	566	570	576	583

DATE	24.10.2016	DOCUMENT NO.	SED 5144498_001 00
DFTR.	24.10.2016	NAME	BUTERUS
CHKD.	26.10.2016	WREDE	1077332
STANDJ	26.10.2016	CHANGE NO.	1077332
		PRODASTSCHUK	-

DIMENSION
IN mm
EXCEPT AS
NOTED



ON-LOAD TAP-CHANGER VACUTAP® VR
VR S/M/L/H II 652/702/1002/1302 - 72,5...362 kV - RE/RF
DIMENSION DRAWING

SERIAL NUMBER

MATERIAL NUMBER
100178600E

SHEET
2/2

© MASCHINENFABRIK REINHAUSEN GMBH 2018
 THE REPRODUCTION, DISTRIBUTION AND UTILIZATION OF THIS DOCUMENT AS WELL AS THE COMMUNICATION OF ITS CONTENTS TO OTHERS WITHOUT EXPRESS AUTHORIZATION IS PROHIBITED. OFFENDERS WILL BE HELD LIABLE FOR THE PAYMENT OF DAMAGES. ALL RIGHTS RESERVED IN THE EVENT OF THE GRANT OF A PATENT, UTILITY MODEL OR DESIGN.

DATE	NAME	DOCUMENT NO.
DFTR. 18.01.2018	RAEDLINGER	SED 5144516 001 02
CHKD. 23.01.2018	MENZELS	SCALE
STANDJ 23.01.2018	PRODASTSCHUK	1:10
		CHANGE NO. 1085481

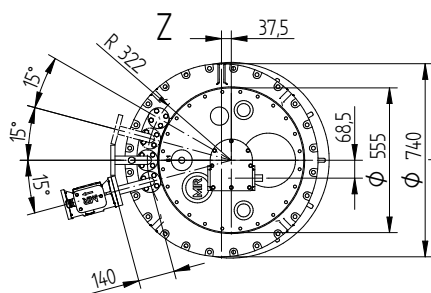
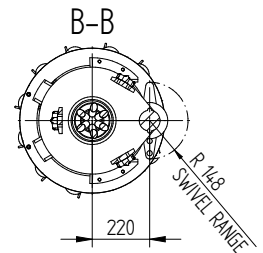
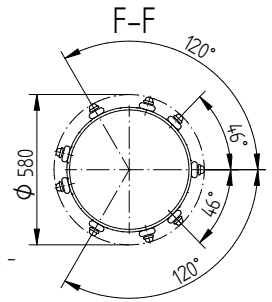
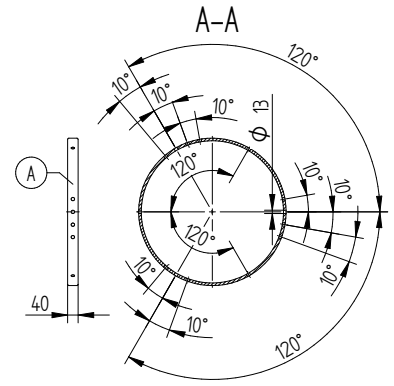
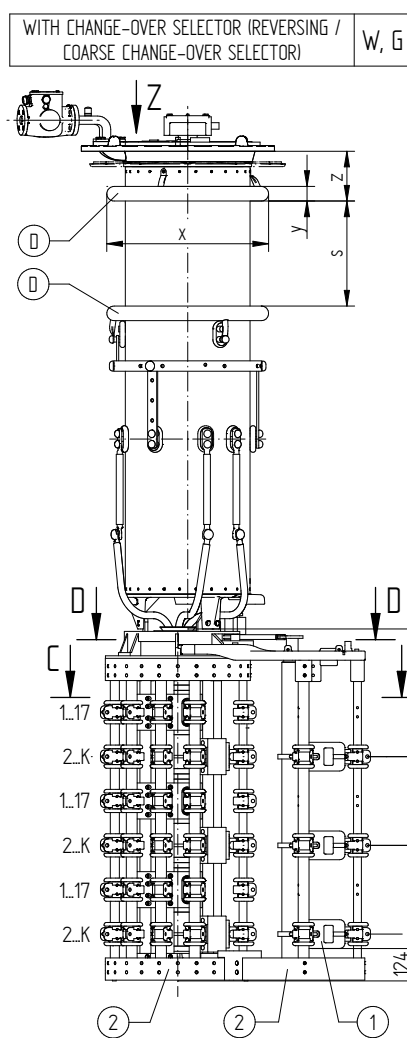
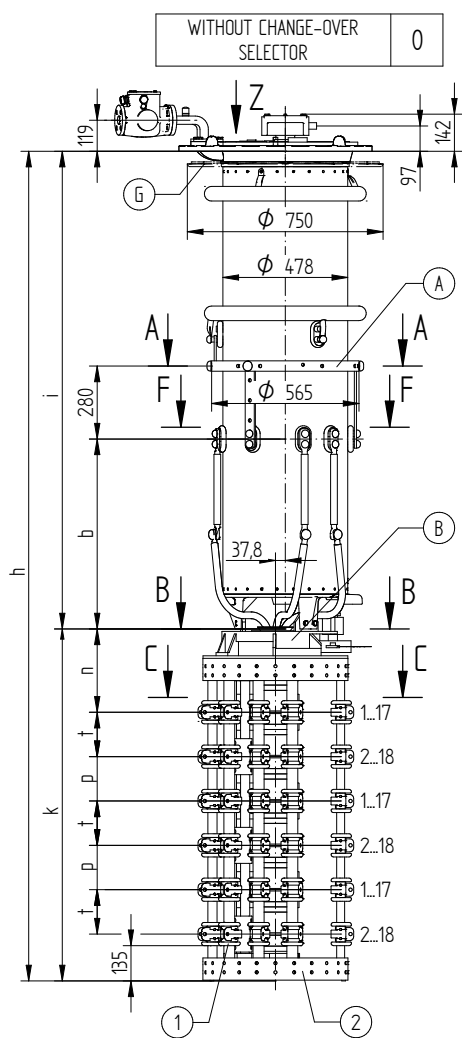

D-D REVERSING CHANGE-OVER SELECTOR (1W)

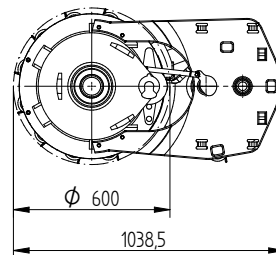

D-D COARSE CHANGE-OVER SELECTOR (1G)

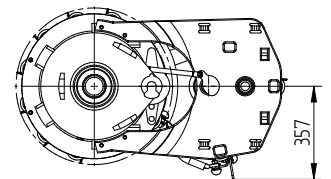

FOR THE TYPE OF OLTC-HEAD REFER TO THE ORDER-SPECIFIC DRAWING OF THE OLTC-HEAD AND DRIVE SHAFTS

- (M) - DRIVE SIDE OF SELECTOR
- (A) - ON-LOAD TAP-CHANGER CURRENT TAKE-OFF TERMINAL
- (B) - IS CONNECTED TO POTENTIAL OF (A)
- (D) - SHIELDING RINGS FOR UM OF 170 kV OR GREATER
- (G) - SUPPORTING FLANGE FOR THE BELL-TYPE TANK INSTALLATION IS OPTIONAL
- (1) - BOTTOM-MOST LIVE PARTS; THESE ARE CONNECTED TO THE POTENTIAL OF THE ASSOCIATED AND/OR WIRED CONNECTION CONTACT
- (2) - SELECTOR BASE IS MADE OF INSULATING MATERIAL

- THE DETAILED CONNECTION DIAGRAM IS BINDING FOR THE DESIGNATION OF THE CONNECTION CONTACTS AND PHASES
- C-C: REFER TO 10009030
- D-D: TYPE WITH CONNECTING LEAD 3W/3G REFER TO 10010019

DIMENSION IN mm EXCEPT AS NOTED



ON-LOAD TAP-CHANGER VACUTAP® VR
 VR S/M/L/H III 650/700/1000/1300 - 72.5...245 kV - RC/RD/RDE
 DIMENSION DRAWING

SERIAL NUMBER

MATERIAL NUMBER 100178641E SHEET 1/2

© MASCHINENFABRIK REINHAUSEN GMBH 2018
 THE REPRODUCTION, DISTRIBUTION AND UTILIZATION OF THIS DOCUMENT AS WELL AS THE COMMUNICATION OF ITS CONTENTS TO OTHERS WITHOUT EXPRESS AUTHORIZATION IS PROHIBITED. OFFENDERS WILL BE HELD LIABLE FOR THE PAYMENT OF DAMAGES. ALL RIGHTS RESERVED IN THE EVENT OF THE GRANT OF A PATENT, UTILITY MODEL OR DESIGN.

DATE	NAME	DOCUMENT NO.
DFTR. 18.01.2018	RAEDLINGER	SED 5144516 001 02
CHKD. 23.01.2018	MENZELS	SCALE 1:10
STANDJ 23.01.2018	PRODASTSCHUK	CHANGE NO. 1085481

VACUTAP® VRS

SELECTOR SIZE	RC				RD / RDE				
Um [kV]	72,5	123	170	245	72,5	123	170	245	
DIMENSIONS [mm]	h	2517	2647	2777	2877	2757	2887	3017	3117
	i	1168	1298	1428	1528	1168	1298	1428	1528
	b	425				425			
	s	-	-	302	402	-	-	302	402
	Z	-	-	191	191	-	-	191	191
	X	-	-	∅ 620	∅ 620	-	-	∅ 620	∅ 620
	y	-	-	∅ 56	∅ 56	-	-	∅ 56	∅ 56
	k	1349				1589			
	n	319				359			
	t	170				210			
	p	170				210			
	r	340				420			
q	489				569				
OIL VOLUME [dm³]	150	170	190	210	150	170	190	210	
DISPLACEMENT [dm³]	278	298	328	348	284	304	334	354	
MAX. WEIGHT [kg]	502	508	520	524	514	520	532	536	

VACUTAP® VRM / VRH 650

SELECTOR SIZE	RC				RD / RDE				
Um [kV]	72,5	123	170	245	72,5	123	170	245	
DIMENSIONS [mm]	h	2668	2798	2928	3028	2908	3038	3168	3268
	i	1319	1449	1579	1679	1319	1449	1579	1679
	b	576				576			
	s	-	-	302	402	-	-	302	402
	Z	-	-	191	191	-	-	191	191
	X	-	-	∅ 620	∅ 620	-	-	∅ 620	∅ 620
	y	-	-	∅ 56	∅ 56	-	-	∅ 56	∅ 56
	k	1349				1589			
	n	319				359			
	t	170				210			
	p	170				210			
	r	340				420			
q	489				569				
OIL VOLUME [dm³]	170	190	220	235	170	190	220	235	
DISPLACEMENT [dm³]	298	328	358	378	304	334	364	384	
MAX. WEIGHT [kg]	522	529	541	545	534	541	553	557	

VACUTAP® VRL / VRH 1300

SELECTOR SIZE	RC				RD / RDE				
Um [kV]	72,5	123	170	245	72,5	123	170	245	
DIMENSIONS [mm]	h	2820	2950	3080	3180	3060	3190	3320	3420
	i	1471	1601	1731	1831	1471	1601	1731	1831
	b	728				728			
	s	-	-	302	402	-	-	302	402
	Z	-	-	191	191	-	-	191	191
	X	-	-	∅ 620	∅ 620	-	-	∅ 620	∅ 620
	y	-	-	∅ 56	∅ 56	-	-	∅ 56	∅ 56
	k	1349				1589			
	n	319				359			
	t	170				210			
	p	170				210			
	r	340				420			
q	489				569				
OIL VOLUME [dm³]	200	220	240	260	200	220	240	260	
DISPLACEMENT [dm³]	328	358	388	408	334	364	394	414	
MAX. WEIGHT [kg]	540	546	559	562	552	558	571	574	

DIMENSION IN mm EXCEPT AS NOTED



ON-LOAD TAP-CHANGER VACUTAP® VR
 VR S/M/L/H III 650/700/1000/1300 - 72,5...245 kV - RC/RD/RDE
 DIMENSION DRAWING

SERIAL NUMBER

MATERIAL NUMBER 100178641E
 SHEET 2/2

© MASCHINENFABRIK REINHAUSEN GMBH 2016
 THE REPRODUCTION, DISTRIBUTION AND UTILIZATION OF THIS DOCUMENT AS WELL AS THE COMMUNICATION OF ITS CONTENTS TO OTHERS WITHOUT EXPRESS AUTHORIZATION IS PROHIBITED. OFFENDERS WILL BE HELD LIABLE FOR THE PAYMENT OF DAMAGES. ALL RIGHTS RESERVED IN THE EVENT OF THE GRANT OF A PATENT, UTILITY MODEL OR DESIGN.

DATE	NAME	DOCUMENT NO.
DFTR. 25.10.2016	BUTERUS	SED 5'152434-001 00
CHKD. 26.10.2016	WREDE	SCALE -
STAND. 26.10.2016	PRODASTSCHUK	CHANGE NO. 1077332

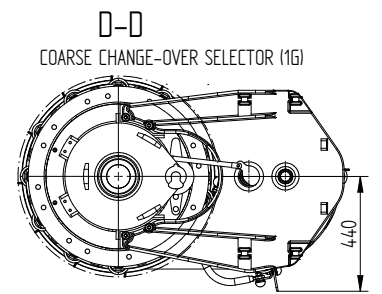
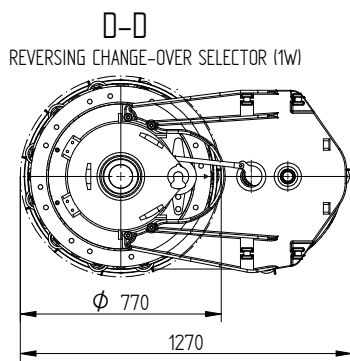
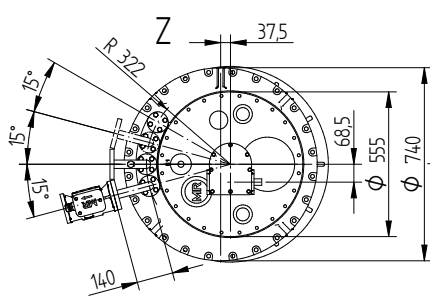
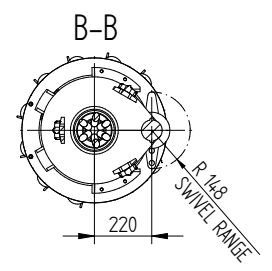
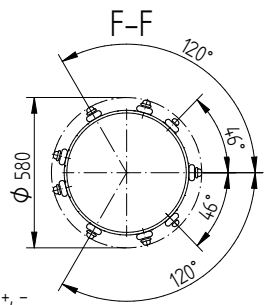
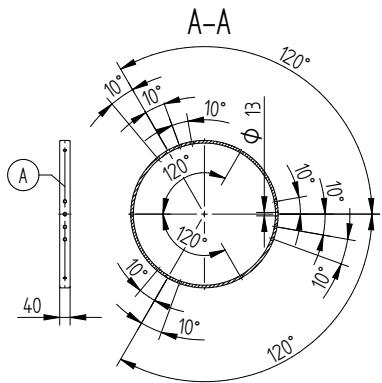
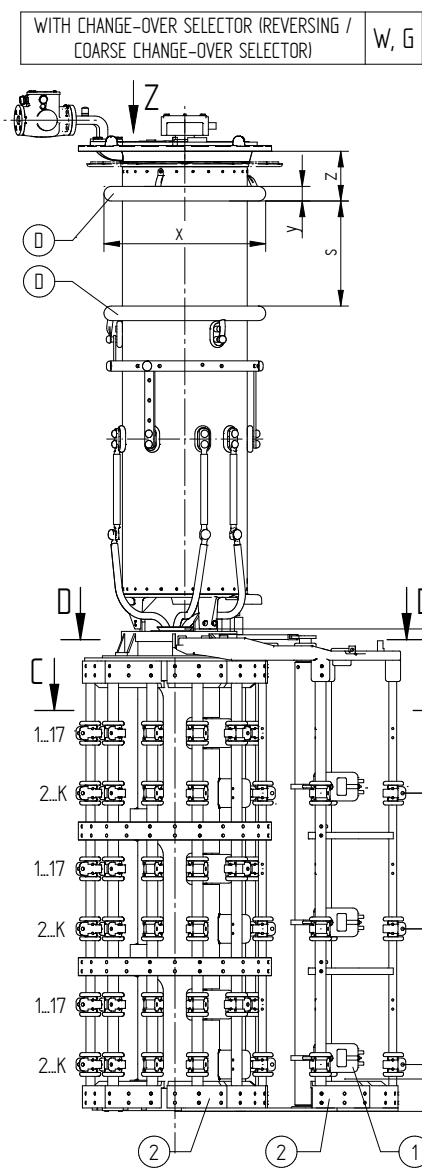
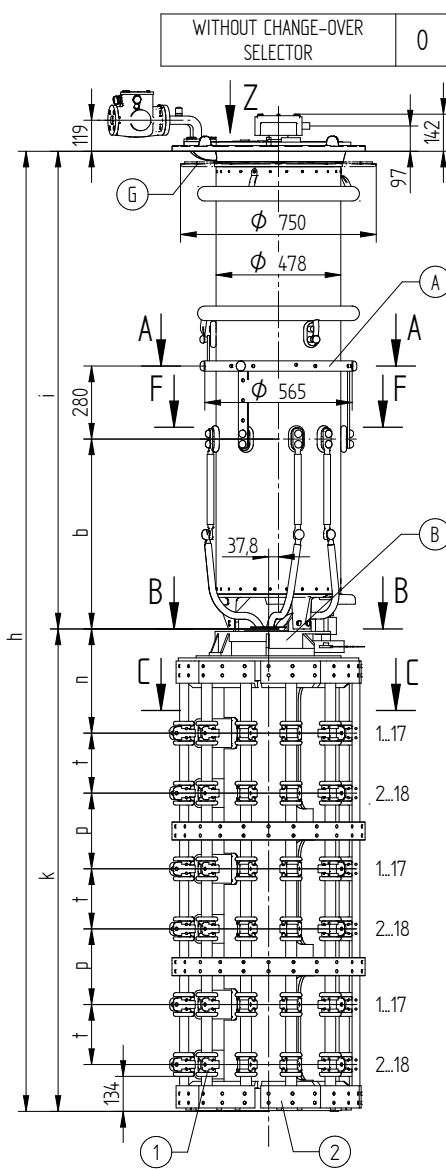

FOR THE TYPE OF OLTC-HEAD REFER TO THE ORDER-SPECIFIC DRAWING OF THE OLTC-HEAD AND DRIVE SHAFTS

- (M) - DRIVE SIDE OF SELECTOR
- (A) - ON-LOAD TAP-CHANGER CURRENT TAKE-OFF TERMINAL
- (B) - IS CONNECTED TO POTENTIAL OF (A)
- (D) - SHIELDING RINGS FOR UM OF 170 kV OR GREATER
- (G) - SUPPORTING FLANGE FOR THE BELL-TYPE TANK INSTALLATION IS OPTIONAL
- (1) - BOTTOM-MOST LIVE PARTS; THESE ARE CONNECTED TO THE POTENTIAL OF THE ASSOCIATED AND/OR WIRED CONNECTION CONTACT
- (2) - SELECTOR BASE IS MADE OF INSULATING MATERIAL

- THE DETAILED CONNECTION DIAGRAM IS BINDING FOR THE DESIGNATION OF THE CONNECTION CONTACTS AND PHASES
 - C-C: REFER TO 10016570
 - D-D: TYPE WITH CONNECTING LEAD 3W/3G REFER TO 10017264

DIMENSION IN mm EXCEPT AS NOTED



ON-LOAD TAP-CHANGER VACUTAP® VR
 VR S/M/L/H III 650/700/1000/1300 - 72,5...245 kV - RE/RF
 DIMENSION DRAWING

SERIAL NUMBER	
-	
MATERIAL NUMBER	SHEET
100178650E	1/2

© MASCHINENFABRIK REINHAUSEN GMBH 2016
 THE REPRODUCTION, DISTRIBUTION AND UTILIZATION OF THIS DOCUMENT AS WELL AS THE COMMUNICATION OF ITS CONTENTS TO OTHERS WITHOUT EXPRESS AUTHORIZATION IS PROHIBITED. OFFENDERS WILL BE HELD LIABLE FOR THE PAYMENT OF DAMAGES. ALL RIGHTS RESERVED IN THE EVENT OF THE GRANT OF A PATENT, UTILITY MODEL OR DESIGN.

VACUTAP® VRS

SELECTOR SIZE		RE				RF			
Um [kV]		72,5	123	170	245	72,5	123	170	245
DIMENSIONS [mm]	h	3018	3148	3278	3378	3178	3308	3438	3538
	i	1168	1298	1428	1528	1168	1298	1428	1528
	b	425				425			
	s	-	-	302	402	-	-	302	402
	z	-	-	191	191	-	-	191	191
	x	-	-	∅ 620	∅ 620	-	-	∅ 620	∅ 620
	y	-	-	∅ 56	∅ 56	-	-	∅ 56	∅ 56
	k	1850				2010			
	n	400				400			
	t	230				230			
	p	290				370			
	r	520				600			
q	630				630				
OIL CONTENT [dm³]		150	170	190	210	150	170	190	210
DISPLACEMENT [dm³]		331	351	381	401	336	356	386	406
MAX. WEIGHT [kg]		611	617	629	633	624	630	642	646

VACUTAP® VRM / VRH 650

SELECTOR SIZE		RE				RF			
Um [kV]		72,5	123	170	245	72,5	123	170	245
DIMENSIONS [mm]	h	3170	3300	3430	3530	3330	3460	3590	3690
	i	1320	1450	1580	1680	1320	1450	1580	1680
	b	576				576			
	s	-	-	302	402	-	-	302	402
	z	-	-	191	191	-	-	191	191
	x	-	-	∅ 620	∅ 620	-	-	∅ 620	∅ 620
	y	-	-	∅ 56	∅ 56	-	-	∅ 56	∅ 56
	k	1850				2010			
	n	400				400			
	t	230				230			
	p	290				370			
	r	520				600			
q	630				630				
OIL CONTENT [dm³]		170	190	220	235	170	190	220	235
DISPLACEMENT [dm³]		351	381	411	431	356	386	416	436
MAX. WEIGHT [kg]		631	638	650	654	644	651	663	667

VACUTAP® VRL / VRH 1300

SELECTOR SIZE		RE				RF			
Um [kV]		72,5	123	170	245	72,5	123	170	245
DIMENSIONS [mm]	h	3321	3451	3581	3681	3481	3611	3741	3841
	i	1471	1601	1731	1831	1471	1601	1731	1831
	b	728				728			
	s	-	-	302	402	-	-	302	402
	z	-	-	191	191	-	-	191	191
	x	-	-	∅ 620	∅ 620	-	-	∅ 620	∅ 620
	y	-	-	∅ 56	∅ 56	-	-	∅ 56	∅ 56
	k	1850				2010			
	n	400				400			
	t	230				230			
	p	290				370			
	r	520				600			
q	630				630				
OIL CONTENT [dm³]		200	220	240	260	200	220	240	260
DISPLACEMENT [dm³]		381	411	441	461	386	416	446	466
MAX. WEIGHT [kg]		649	655	668	671	662	668	681	684

DATE	NAME	DOCUMENT NO.
DFTR. 25.10.2016	BUTERUS	SED 5152434-001 00
CHKD. 26.10.2016	WREDE	CHANGE NO.
STAND. 26.10.2016	PRODASTSCHUK	1077332
		SCALE
		-

DIMENSION
IN mm
EXCEPT AS
NOTED



ON-LOAD TAP-CHANGER VACUTAP® VR
 VR S/M/L/H III 650/700/1000/1300 - 72,5...245 kV - RE/RF
 DIMENSION DRAWING

SERIAL NUMBER

MATERIAL NUMBER
100178650E

SHEET
2/2

© MASCHINENFABRIK REINHAUSEN GMBH 2018
 THE REPRODUCTION, DISTRIBUTION AND UTILIZATION OF THIS DOCUMENT AS WELL AS THE COMMUNICATION OF ITS CONTENTS TO OTHERS WITHOUT EXPRESS AUTHORIZATION IS PROHIBITED. OFFENDERS WILL BE HELD LIABLE FOR THE PAYMENT OF DAMAGES. ALL RIGHTS RESERVED IN THE EVENT OF A PATENT, UTILITY MODEL OR DESIGN.

DATE	NAME	DOCUMENT NO.
DFTR. 16.05.2018	RAEDLINGER	SED 5143085 001 01
CHKD. 16.05.2018	HAUER	SCALE
STAND. 16.05.2018	PRODASTSCHUK	1087395
		1:10

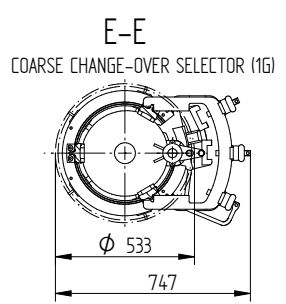
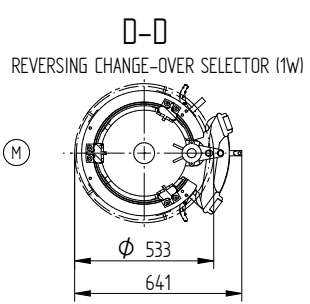
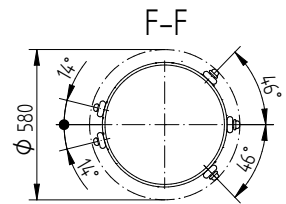
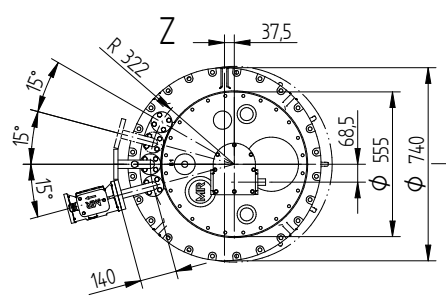
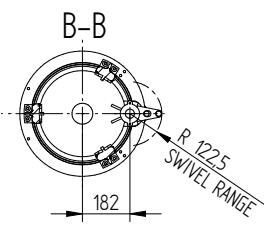
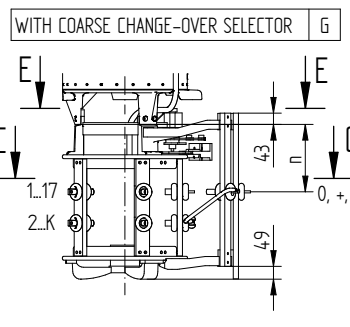
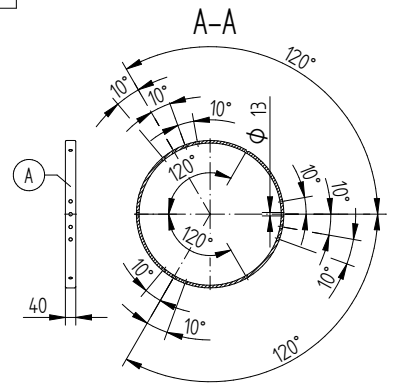
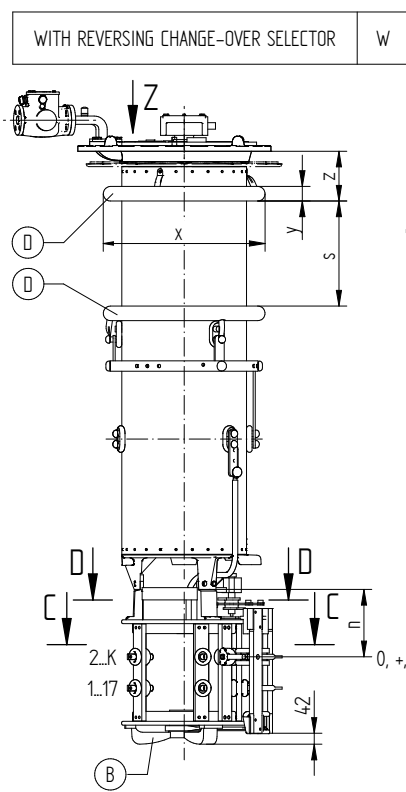
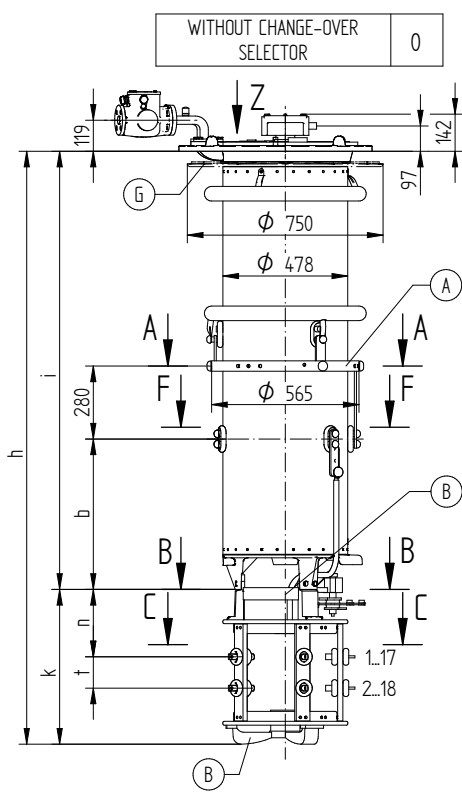

FOR THE TYPE OF OLTC-HEAD REFER TO THE ORDER-SPECIFIC DRAWING OF THE OLTC-HEAD AND DRIVE SHAFTS

- (M) - DRIVE SIDE OF SELECTOR
- (A) - ON-LOAD TAP-CHANGER CURRENT TAKE-OFF TERMINAL
- (B) - IS CONNECTED TO POTENTIAL OF (A)
- (D) - SHIELDING RINGS FOR UM OF 170 KV OR GREATER
- (G) - SUPPORTING FLANGE FOR THE BELL-TYPE TANK INSTALLATION IS OPTIONAL

- THE DETAILED CONNECTION DIAGRAM IS BINDING FOR THE DESIGNATION OF THE CONNECTION CONTACTS AND PHASES
- C-C: REFER TO 10018046
- D-D AND E-E: TYPE WITH CONNECTING LEAD 3W/3G REFER TO 723590

DIMENSION IN mm EXCEPT AS NOTED



ON-LOAD TAP-CHANGER VACUTAP® VR
 VRS/M | 701 - 72,5...420 kV - B/C/D/DE
 DIMENSION DRAWING

SERIAL NUMBER

MATERIAL NUMBER
 100178581E

SHEET
 1 / 2

© MASCHINENFABRIK REINHAUSEN GMBH 2018
 THE REPRODUCTION, DISTRIBUTION AND UTILIZATION OF THIS DOCUMENT AS WELL AS THE COMMUNICATION OF ITS CONTENTS TO OTHERS WITHOUT EXPRESS AUTHORIZATION IS PROHIBITED. OFFENDERS WILL BE HELD LIABLE FOR THE PAYMENT OF DAMAGES. ALL RIGHTS RESERVED IN THE EVENT OF THE GRANT OF A PATENT, UTILITY MODEL OR DESIGN.

VACUTAP® VRS

SELECTOR SIZE		B							C							D/DE						
Um [kV]		72,5	123	170	245	300	362	420	72,5	123	170	245	300	362	420	72,5	123	170	245	300	362	420
DIMENSIONS [mm]	h	1686	1816	1946	2046	2198	2301	2420	1761	1891	2021	2121	2273	2376	2495	1956	2086	2216	2316	2468	2571	2690
	i	1168	1298	1428	1528	1680	1783	1902	1168	1298	1428	1528	1680	1783	1902	1168	1298	1428	1528	1680	1783	1902
	b	425							425							425						
	s	-	-	302	402	554	573	692	-	-	302	402	554	573	692	-	-	302	402	554	573	692
	z	-	-	191	191	191	228	228	-	-	191	191	191	228	228	-	-	191	191	191	228	228
	x	-	-	∅ 620	∅ 620	∅ 620	∅ 695	∅ 695	-	-	∅ 620	∅ 620	∅ 620	∅ 695	∅ 695	-	-	∅ 620	∅ 620	∅ 620	∅ 695	∅ 695
	y	-	-	∅ 56	∅ 56	∅ 56	∅ 100	∅ 100	-	-	∅ 56	∅ 56	∅ 56	∅ 100	∅ 100	-	-	∅ 56	∅ 56	∅ 56	∅ 100	∅ 100
	k	518							593							788						
	n	233							258							323						
	t	95							120							185						
OIL CONTENT [dm³]	160	180	200	220	240	260	280	160	180	200	220	240	260	280	160	180	200	220	240	260	280	
DISPLACEMENT [dm³]	258	278	308	328	358	398	418	258	278	308	328	358	398	418	260	280	310	330	360	400	420	
MAX. WEIGHT [kg]	312	318	331	334	340	347	352	322	328	341	344	350	357	362	333	339	352	355	361	368	373	

VACUTAP® VRM

SELECTOR SIZE		B							C							D/DE						
Um [kV]		72,5	123	170	245	300	362	420	72,5	123	170	245	300	362	420	72,5	123	170	245	300	362	420
DIMENSIONS [mm]	h	1838	1968	2098	2198	2350	2453	2572	1913	2043	2173	2273	2425	2528	2647	2108	2238	2368	2468	2620	2723	2842
	i	1320	1450	1580	1680	1832	1935	2054	1320	1450	1580	1680	1832	1935	2054	1320	1450	1580	1680	1832	1935	2054
	b	576							576							576						
	s	-	-	302	402	554	573	692	-	-	302	402	554	573	692	-	-	302	402	554	573	692
	z	-	-	191	191	191	228	228	-	-	191	191	191	228	228	-	-	191	191	191	228	228
	x	-	-	∅ 620	∅ 620	∅ 620	∅ 695	∅ 695	-	-	∅ 620	∅ 620	∅ 620	∅ 695	∅ 695	-	-	∅ 620	∅ 620	∅ 620	∅ 695	∅ 695
	y	-	-	∅ 56	∅ 56	∅ 56	∅ 100	∅ 100	-	-	∅ 56	∅ 56	∅ 56	∅ 100	∅ 100	-	-	∅ 56	∅ 56	∅ 56	∅ 100	∅ 100
	k	518							593							788						
	n	233							258							323						
	t	95							120							185						
OIL CONTENT [dm³]	180	200	230	245	270	285	305	180	200	230	245	270	285	305	180	200	230	245	270	285	305	
DISPLACEMENT [dm³]	278	308	338	358	388	428	448	278	308	338	358	388	428	448	280	310	340	360	390	430	450	
MAX. WEIGHT [kg]	321	327	340	344	349	356	361	331	337	350	354	359	366	371	342	348	361	365	370	377	382	

DATE	NAME	DOCUMENT NO.
16.05.2018	RAEDLINGER	SED 5143085 001 01
16.05.2018	HAUER	CHANGE NO.
16.05.2018	PRODASTSCHUK	1087395
DFTR.	SCALE	1:10

DIMENSION
IN mm
EXCEPT AS
NOTED



ON-LOAD TAP-CHANGER VACUTAP® VR
VRS/M | 701 - 72,5...420 kV - B/C/D/DE
DIMENSION DRAWING

SERIAL NUMBER

MATERIAL NUMBER	SHEET
100178581E	2/2

© MASCHINENFABRIK REINHAUSEN GMBH 2016
 THE REPRODUCTION, DISTRIBUTION AND UTILIZATION OF THIS DOCUMENT AS WELL AS THE COMMUNICATION OF ITS CONTENTS TO OTHERS WITHOUT EXPRESS AUTHORIZATION IS PROHIBITED. OFFENDERS WILL BE HELD LIABLE FOR THE PAYMENT OF DAMAGES. ALL RIGHTS RESERVED IN THE EVENT OF THE GRANT OF A PATENT, UTILITY MODEL OR DESIGN.

DATE	NAME	DOCUMENT NO.
DFTR. 20.10.2016	BUTERUS	SED 5144502 001 00
CHKD. 26.10.2016	WREDE	SCALE
STAND. 26.10.2016	PRODASTSCHUK	1077332

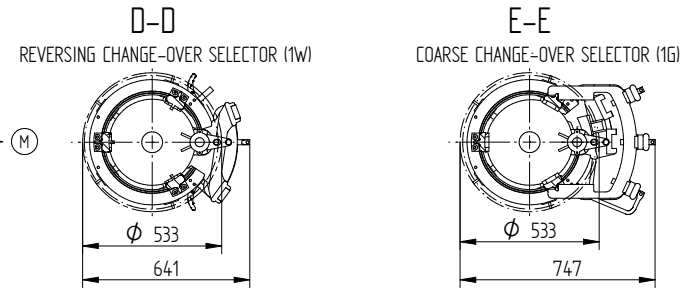
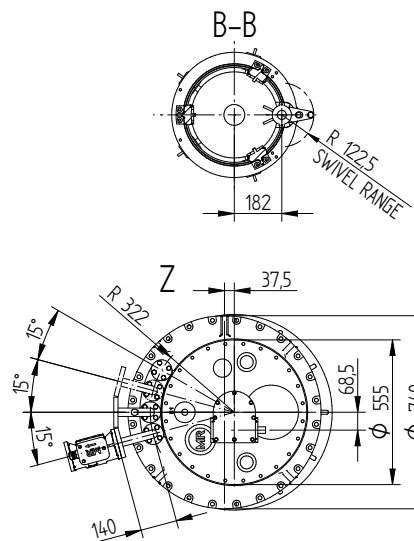
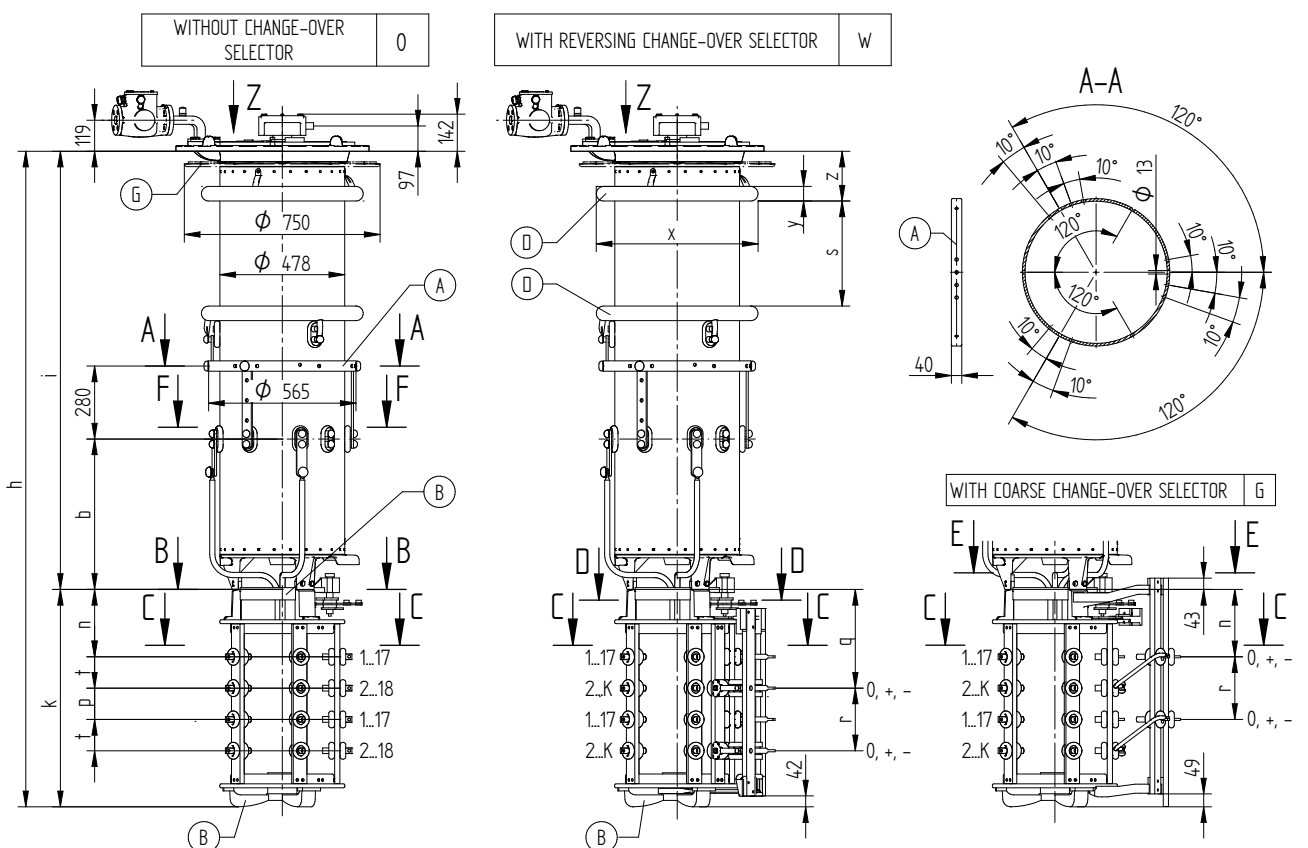

FOR THE TYPE OF OLTC-HEAD REFER TO THE ORDER-SPECIFIC DRAWING OF THE OLTC-HEAD AND DRIVE SHAFTS

- (M) - DRIVE SIDE OF SELECTOR
- (A) - ON-LOAD TAP-CHANGER CURRENT TAKE-OFF TERMINAL
- (B) - IS CONNECTED TO POTENTIAL OF (A)
- (D) - SHIELDING RINGS FOR UM OF 170 kV OR GREATER
- (G) - SUPPORTING FLANGE FOR THE BELL-TYPE TANK INSTALLATION IS OPTIONAL
- THE DETAILED CONNECTION DIAGRAM IS BINDING FOR THE DESIGNATION OF THE CONNECTION CONTACTS AND PHASES
- C-C: REFER TO 898013
- D-D AND E-E: TYPE WITH CONNECTING LEAD 3W/3G REFER TO 723590

DIMENSION IN mm EXCEPT AS NOTED



ON-LOAD TAP-CHANGER VACUTAP® VR
 VR S/M II 702 - 725...362 kV - B/C/D/E
 DIMENSION DRAWING

SERIAL NUMBER	
-	
MATERIAL NUMBER	SHEET
100178610E	1/2

© MASCHINENFABRIK REINHAUSEN GMBH 2016
 THE REPRODUCTION, DISTRIBUTION AND UTILIZATION OF THIS DOCUMENT AS WELL AS THE COMMUNICATION OF ITS CONTENTS TO OTHERS WITHOUT EXPRESS AUTHORIZATION IS PROHIBITED. OFFENDERS WILL BE HELD LIABLE FOR THE PAYMENT OF DAMAGES. ALL RIGHTS RESERVED IN THE EVENT OF THE GRANT OF A PATENT, UTILITY MODEL OR DESIGN.

VACUTAP® VRS

SELECTOR SIZE		B						C						D/DE					
Um [kV]		72,5	123	170	245	300	362	72,5	123	170	245	300	362	72,5	123	170	245	300	362
DIMENSIONS [mm]	h	1876	2006	2136	2236	2388	2491	2001	2131	2261	2361	2513	2616	2326	2456	2586	2686	2838	2941
	i	1168	1298	1428	1528	1680	1783	1168	1298	1428	1528	1680	1783	1168	1298	1428	1528	1680	1783
	b	425						425						425					
	s	-	-	302	402	554	573	-	-	302	402	554	573	-	-	302	402	554	573
	z	-	-	191	191	191	228	-	-	191	191	191	228	-	-	191	191	191	228
	x	-	-	∅ 620	∅ 620	∅ 620	∅ 695	-	-	∅ 620	∅ 620	∅ 620	∅ 695	-	-	∅ 620	∅ 620	∅ 620	∅ 695
	y	-	-	∅ 56	∅ 56	∅ 56	∅ 100	-	-	∅ 56	∅ 56	∅ 56	∅ 100	-	-	∅ 56	∅ 56	∅ 56	∅ 100
	k	708						833						1158					
	n	233						258						323					
	t	95						120						185					
	p	95						120						185					
	r	190						240						370					
	q	328						378						508					
OIL CONTENT [dm³]	155	175	195	215	235	255	155	175	195	215	235	255	155	175	195	215	235	255	
DISPLACEMENT [dm³]	261	281	311	331	361	401	261	281	311	331	361	401	264	284	314	334	364	404	
MAX. WEIGHT [kg]	373	379	392	395	401	408	384	390	403	406	412	419	395	401	414	417	423	430	

VACUTAP® VRM

SELECTOR SIZE		B						C						D/DE					
Um [kV]		72,5	123	170	245	300	362	72,5	123	170	245	300	362	72,5	123	170	245	300	362
DIMENSIONS [mm]	h	2028	2158	2288	2388	2540	2643	2153	2283	2413	2513	2665	2768	2478	2608	2738	2838	2990	3093
	i	1320	1450	1580	1680	1832	1935	1320	1450	1580	1680	1832	1935	1320	1450	1580	1680	1832	1935
	b	576						576						576					
	s	-	-	302	402	554	573	-	-	302	402	554	573	-	-	302	402	554	573
	z	-	-	191	191	191	228	-	-	191	191	191	228	-	-	191	191	191	228
	x	-	-	∅ 620	∅ 620	∅ 620	∅ 695	-	-	∅ 620	∅ 620	∅ 620	∅ 695	-	-	∅ 620	∅ 620	∅ 620	∅ 695
	y	-	-	∅ 56	∅ 56	∅ 56	∅ 100	-	-	∅ 56	∅ 56	∅ 56	∅ 100	-	-	∅ 56	∅ 56	∅ 56	∅ 100
	k	708						833						1158					
	n	233						258						323					
	t	95						120						185					
	p	95						120						185					
	r	190						240						370					
	q	328						378						508					
OIL CONTENT [dm³]	175	195	225	240	265	280	175	195	225	240	265	280	175	195	225	240	265	280	
DISPLACEMENT [dm³]	281	311	341	361	391	431	281	311	341	361	391	431	284	314	344	364	394	434	
MAX. WEIGHT [kg]	389	395	407	411	417	423	400	406	418	422	428	434	411	417	429	433	439	445	

DATE	20.10.2016	NAME	BUTERUS	DOCUMENT NO.	SED 5144502 001 00
DFTR.	26.10.2016	WREDE	PRODASTSCHUK	CHANGE NO.	1077332
CHKD.	26.10.2016	SCALE	-		
STAND.					

DIMENSION
IN mm
EXCEPT AS
NOTED



ON-LOAD TAP-CHANGER VACUTAP® VR
VR S/M II 702 - 72,5...362 kV - B/C/D/DE
DIMENSION DRAWING

SERIAL NUMBER

MATERIAL NUMBER
100178610E

SHEET
2/2

© MASCHINENFABRIK REINHAUSEN GMBH 2016
 THE REPRODUCTION, DISTRIBUTION AND UTILIZATION OF THIS DOCUMENT AS WELL AS THE COMMUNICATION OF ITS CONTENTS TO OTHERS WITHOUT EXPRESS AUTHORIZATION IS PROHIBITED. OFFENDERS WILL BE HELD LIABLE FOR THE PAYMENT OF DAMAGES. ALL RIGHTS RESERVED IN THE EVENT OF THE GRANT OF A PATENT, UTILITY MODEL OR DESIGN.

DATE	08.12.2016	DOCUMENT NO.	SED 5152449 001 01
DFTR.	09.12.2016	NAME	BUTERUS
CHKD.	09.12.2016	CHANGE NO.	1077332
STAND.	09.12.2016	SCALE	-
			WREDE
			KLEYN

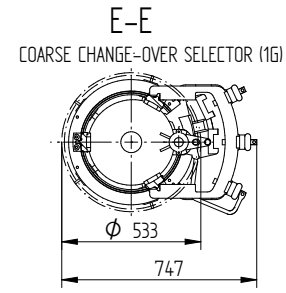
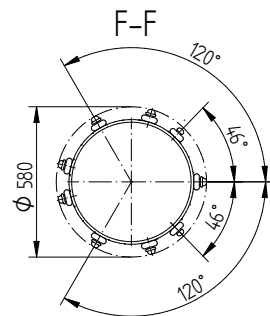
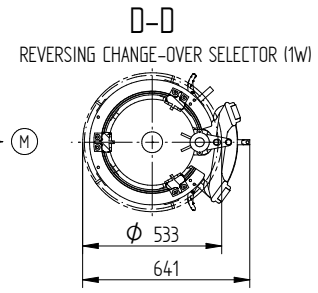
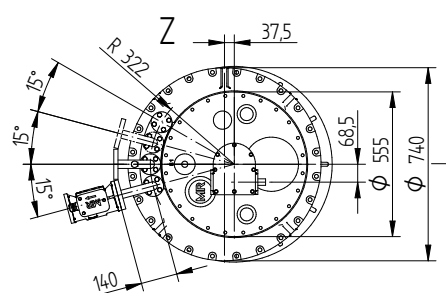
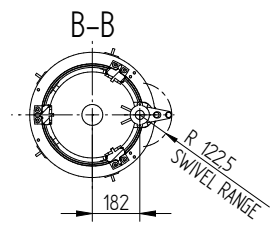
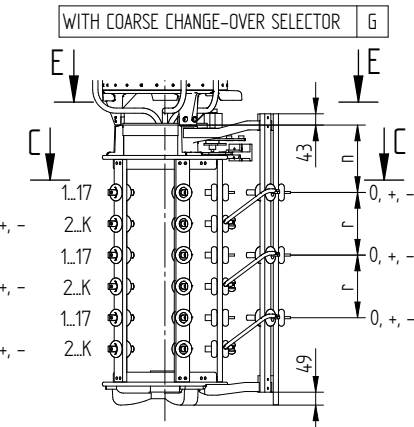
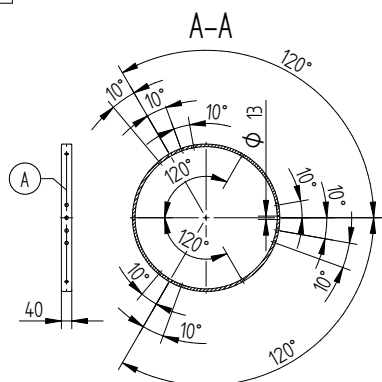
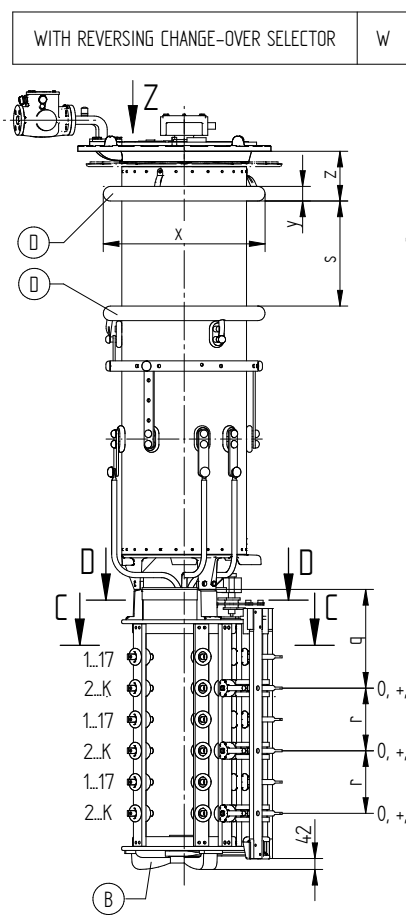
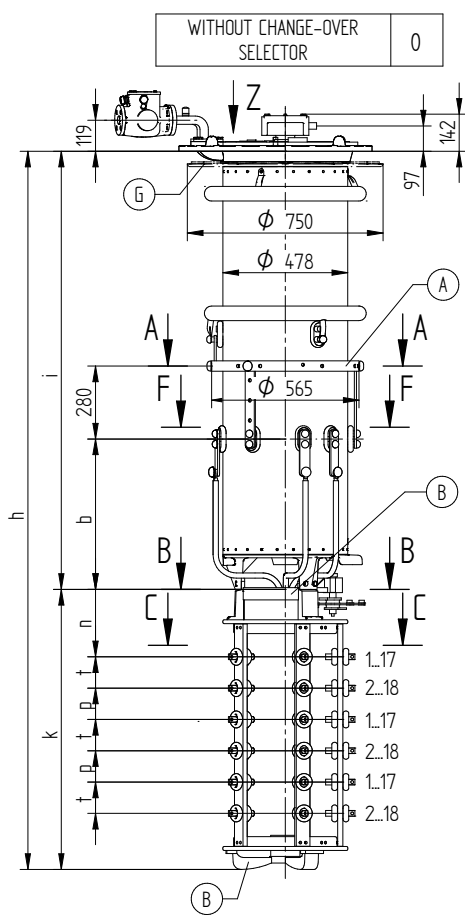

FOR THE TYPE OF OLTC-HEAD REFER TO THE ORDER-SPECIFIC DRAWING OF THE OLTC-HEAD AND DRIVE SHAFTS

- (M) - DRIVE SIDE OF SELECTOR
- (A) - ON-LOAD TAP-CHANGER CURRENT TAKE-OFF TERMINAL
- (B) - IS CONNECTED TO POTENTIAL OF (A)
- (D) - SHIELDING RINGS FOR UM OF 170 kV OR GREATER
- (G) - SUPPORTING FLANGE FOR THE BELL-TYPE TANK INSTALLATION IS OPTIONAL

- THE DETAILED CONNECTION DIAGRAM IS BINDING FOR THE DESIGNATION OF THE CONNECTION CONTACTS AND PHASES
- C-C: REFER TO 898013
- D-D AND E-E: TYPE WITH CONNECTING LEAD 3W/3G REFER TO 723590

DIMENSION IN mm EXCEPT AS NOTED



ON-LOAD TAP-CHANGER VACUTAP® VR
 VR S/M III 700 - 72,5...245 kV - B/C/D/DE
 DIMENSION DRAWING

SERIAL NUMBER	
-	
MATERIAL NUMBER	SHEET
100178660E	1/2

© MASCHINENFABRIK REINHAUSEN GMBH 2016
 THE REPRODUCTION, DISTRIBUTION AND UTILIZATION OF THIS DOCUMENT AS WELL AS THE COMMUNICATION OF ITS CONTENTS TO OTHERS WITHOUT EXPRESS AUTHORIZATION IS PROHIBITED. OFFENDERS WILL BE HELD LIABLE FOR THE PAYMENT OF DAMAGES. ALL RIGHTS RESERVED IN THE EVENT OF THE GRANT OF A PATENT, UTILITY MODEL OR DESIGN.

VACUTAP® VRS

SELECTOR SIZE	B				C				D/DE				
Um [kV]	72,5	123	170	245	72,5	123	170	245	72,5	123	170	245	
DIMENSIONS [mm]	h	2066	2196	2326	2426	2241	2371	2501	2601	2696	2833	2956	3056
	i	1168	1298	1428	1528	1168	1298	1428	1528	1168	1298	1428	1528
	b	425				425				425			
	s	-	-	302	402	-	-	302	402	-	-	302	402
	z	-	-	191	191	-	-	191	191	-	-	191	191
	x	-	-	∅ 620	∅ 620	-	-	∅ 620	∅ 620	-	-	∅ 620	∅ 620
	y	-	-	∅ 56	∅ 56	-	-	∅ 56	∅ 56	-	-	∅ 56	∅ 56
	k	898				1073				1528			
	n	233				258				323			
	t	95				120				185			
	p	95				120				185			
	r	190				240				370			
q	328				378				508				
OIL CONTENT [dm³]	150	170	190	210	150	170	190	210	150	170	190	210	
DISPLACEMENT [dm³]	264	284	314	334	264	284	314	334	272	292	322	342	
MAX. WEIGHT [kg]	437	443	455	459	447	453	465	469	464	470	482	486	

VACUTAP® VRM

SELECTOR SIZE	B				C				D/DE				
Um [kV]	72,5	123	170	245	72,5	123	170	245	72,5	123	170	245	
DIMENSIONS [mm]	h	2218	2348	2478	2578	2393	2523	2653	2753	2848	2978	3108	3208
	i	1320	1450	1580	1680	1320	1450	1580	1680	1320	1450	1580	1680
	b	576				576				576			
	s	-	-	302	402	-	-	302	402	-	-	302	402
	z	-	-	191	191	-	-	191	191	-	-	191	191
	x	-	-	∅ 620	∅ 620	-	-	∅ 620	∅ 620	-	-	∅ 620	∅ 620
	y	-	-	∅ 56	∅ 56	-	-	∅ 56	∅ 56	-	-	∅ 56	∅ 56
	k	898				1073				1528			
	n	233				258				323			
	t	95				120				185			
	p	95				120				185			
	r	190				240				370			
q	328				378				508				
OIL CONTENT [dm³]	170	190	220	235	170	190	220	235	170	190	220	235	
DISPLACEMENT [dm³]	284	314	344	364	284	314	344	364	292	322	352	372	
MAX. WEIGHT [kg]	457	464	476	480	467	474	486	490	484	491	503	507	

DATE	08.12.2016	NAME	BUTERUS	DOCUMENT NO.	SED 5152449 001 01
DFTR.	09.12.2016	WREDE	KLEYN	CHANGE NO.	1077332
CHKD.	09.12.2016			SCALE	-
STAND.					

DIMENSION
IN mm
EXCEPT AS
NOTED



ON-LOAD TAP-CHANGER VACUTAP® VR
 VR S/M III 700 - 72,5...245 kV - B/C/D/DE
 DIMENSION DRAWING

SERIAL NUMBER

MATERIAL NUMBER
100178660E

SHEET
2/2

© MASCHINENFABRIK REINHAUSEN GMBH 2018

Weitergabe sowie Vervielfältigung dieses Dokuments, Verwertung und Mitteilung seines Inhaltes sind verboten, soweit nicht ausdrücklich gestattet. Zuwiderhandlungen verpflichten zu Schadensersatz. Alle Rechte für den Fall der Patent-, Gebrauchsmuster- oder Designeintragung vorbehalten.

Datum	Name	Dokumentnummer
16.05.2018	RAEDLINGER	SED 6017860 001 01
gepr. 16.05.2018	HAUER	Änderungsnummer
Norm. 16.05.2018	PRODASTSCHUK	1087395
		1:10

Maßangaben
in mm, soweit
nicht anders
angegeben



ON-LOAD TAP-CHANGER VACUTAP® VR
VRS/VRM I 1001 - 72,5...420 kV - B/C/D/DE
DIMENSION DRAWING

Serialnummer

Materialnummer
101169840E

Blatt
1/2

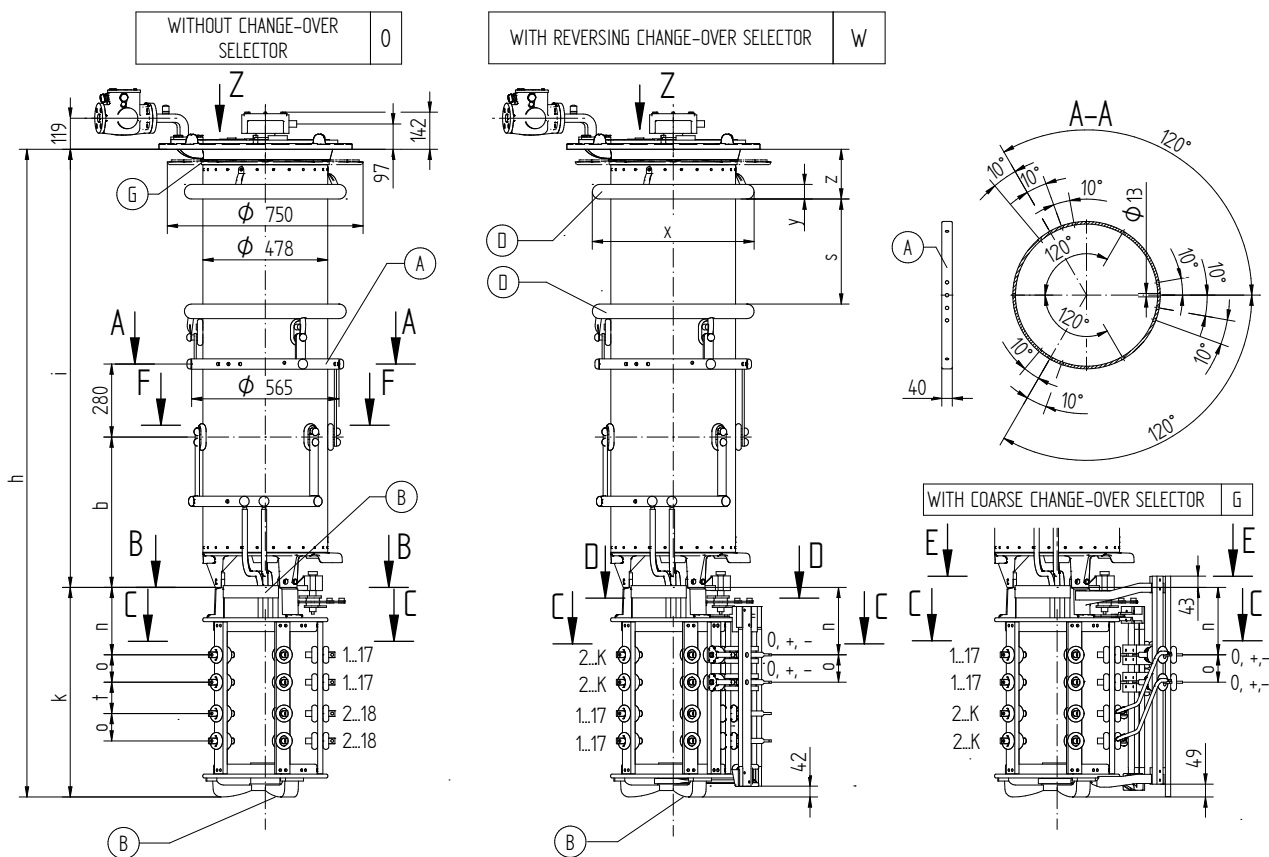

FOR THE TYPE OF THE OLTC-HEAD REFER TO THE ORDER-SPECIFIC DRAWING OF THE OLTC-HEAD AND DRIVE SHAFTS

- (M) - DRIVE SIDE OF SELECTOR
- (A) - ON-LOAD TAP-CHANGER CURRENT TAKE-OFF TERMINAL
- (B) - IS CONNECTED TO POTENTIAL OF (A)
- (D) - SHIELDING RINGS FOR UM OF 170 kV OR GREATER
- (G) - SUPPORTING FLANGE FOR THE BELL-TYPE TANK INSTALLATION IS OPTIONAL

- THE DETAILED CONNECTION DIAGRAM IS BINDING FOR THE DESIGNATION OF THE CONNECTION CONTACTS AND PHASES
- C-C: REFER TO 10018046
- D-D AND E-E: TYPE WITH CONNECTING LEAD 3W/3G REFER TO 723590
- CONNECTING OF PARALLEL SELECTOR PLANES REFER TO 10117014

© MASCHINENFABRIK REINHAUSEN GMBH 2018
 Weitergabe sowie Vervielfältigung dieses Dokuments, Verwertung und Mitteilung seines Inhaltes sind verboten, soweit nicht ausdrücklich gestattet.
 Zuwiderhandlungen verpflichten zu Schadenersatz. Alle Rechte für den Fall der Patent-, Gebrauchsmuster- oder Designeintragung vorbehalten.

VACUTAP® VRS

SELECTOR SIZE		B							C							D/DE						
Um [kV]		72,5	123	170	245	300	362	420	72,5	123	170	245	300	362	420	72,5	123	170	245	300	362	420
DIMENSIONS [mm]	h	1896	2026	2156	2256	2408	2511	2630	1971	2101	2231	2331	2483	2586	2705	2166	2296	2426	2526	2678	2781	2900
	i	1168	1298	1428	1528	1680	1783	1902	1168	1298	1428	1528	1680	1783	1902	1168	1298	1428	1528	1680	1783	1902
	b	425							425							425						
	s	-	-	302	402	554	573	692	-	-	302	402	554	573	692	-	-	302	402	554	573	692
	z	-	-	191	191	191	228	228	-	-	191	191	191	228	228	-	-	191	191	191	228	228
	x	-	-	∅ 620	∅ 620	∅ 620	∅ 695	∅ 695	-	-	∅ 620	∅ 620	∅ 620	∅ 695	∅ 695	-	-	∅ 620	∅ 620	∅ 620	∅ 695	∅ 695
	y	-	-	∅ 56	∅ 56	∅ 56	∅ 100	∅ 100	-	-	∅ 56	∅ 56	∅ 56	∅ 100	∅ 100	-	-	∅ 56	∅ 56	∅ 56	∅ 100	∅ 100
	k	728							803							998						
	n	233							258							323						
	o	105							105							105						
t	95							120							185							
OIL VOLUME [dm³]		160	180	200	220	240	260	280	160	180	200	220	240	260	280	160	180	200	220	240	260	280
DISPLACEMENT [dm³]		261	281	311	331	361	401	421	261	281	311	331	361	401	421	264	284	314	334	364	404	424
MAX. WEIGHT [kg]		322	328	341	344	350	357	362	332	338	351	354	360	367	372	348	354	367	370	376	383	388

VACUTAP® VRM

SELECTOR SIZE		B							C							D/DE						
Um [kV]		72,5	123	170	245	300	362	420	72,5	123	170	245	300	362	420	72,5	123	170	245	300	362	420
DIMENSIONS [mm]	h	2048	2178	2308	2408	2560	2663	2782	2123	2253	2383	2483	2635	2738	2857	2318	2448	2578	2678	2830	2933	3052
	i	1320	1450	1580	1680	1832	1935	2054	1320	1450	1580	1680	1832	1935	2054	1320	1450	1580	1680	1832	1935	2054
	b	576							576							576						
	s	-	-	302	402	554	573	692	-	-	302	402	554	573	692	-	-	302	402	554	573	692
	z	-	-	191	191	191	228	228	-	-	191	191	191	228	228	-	-	191	191	191	228	228
	x	-	-	∅ 620	∅ 620	∅ 620	∅ 695	∅ 695	-	-	∅ 620	∅ 620	∅ 620	∅ 695	∅ 695	-	-	∅ 620	∅ 620	∅ 620	∅ 695	∅ 695
	y	-	-	∅ 56	∅ 56	∅ 56	∅ 100	∅ 100	-	-	∅ 56	∅ 56	∅ 56	∅ 100	∅ 100	-	-	∅ 56	∅ 56	∅ 56	∅ 100	∅ 100
	k	728							803							998						
	n	233							258							323						
	o	105							105							105						
t	95							120							185							
OIL VOLUME [dm³]		180	200	230	245	270	285	305	180	200	230	245	270	285	305	180	200	230	245	270	285	305
DISPLACEMENT [dm³]		281	311	341	361	391	431	451	281	311	341	361	391	431	451	284	314	344	364	394	434	454
MAX. WEIGHT [kg]		331	337	350	354	359	366	371	341	347	360	364	369	376	381	357	363	376	380	385	392	397

Datum	Name		Dokumentnummer	
	16.05.2018	RAEDLINGER	SED 6017860 001 01	
	16.05.2018	HAUER	Änderungsnummer	Maßstab
Norm.	16.05.2018	PRODAJTSCHUK	1087395	1:10

Maßangaben
in mm, soweit
nicht anders
angegeben



ON-LOAD TAP-CHANGER VACUTAP® VR
 VRS/VRM I 1001 - 72,5...420 kV - B/C/D/DE
 DIMENSION DRAWING

Serialnummer	
Materialnummer	Blatt
101169840E	2/2

© MASCHINENFABRIK REINHAUSEN GMBH 2018

Weitergabe sowie Vervielfältigung dieses Dokuments, Verwertung und Mitteilung seines Inhaltes sind verboten, soweit nicht ausdrücklich gestattet. Zuwiderhandlungen verpflichten zu Schadenersatz. Alle Rechte für den Fall der Patent-, Gebrauchsmuster- oder Designeintragung vorbehalten.

Datum	Name	Dokumentnummer
16.05.2018	RAEDLINGER	SED 6018611 001 01
Gez. bepr.	HAUER	Änderungsnummer
16.05.2018	PRODASTSCHUK	1087395
Norm.		110

Maßangaben
in mm, soweit
nicht anders
angegeben



ON-LOAD TAP-CHANGER VACUTAP® VR
VRS/VRM I 1301 - 72,5...420 kV - B/C/D/DE
DIMENSION DRAWING

Serialnummer

Materialnummer
101169860E

Blatt
1/2

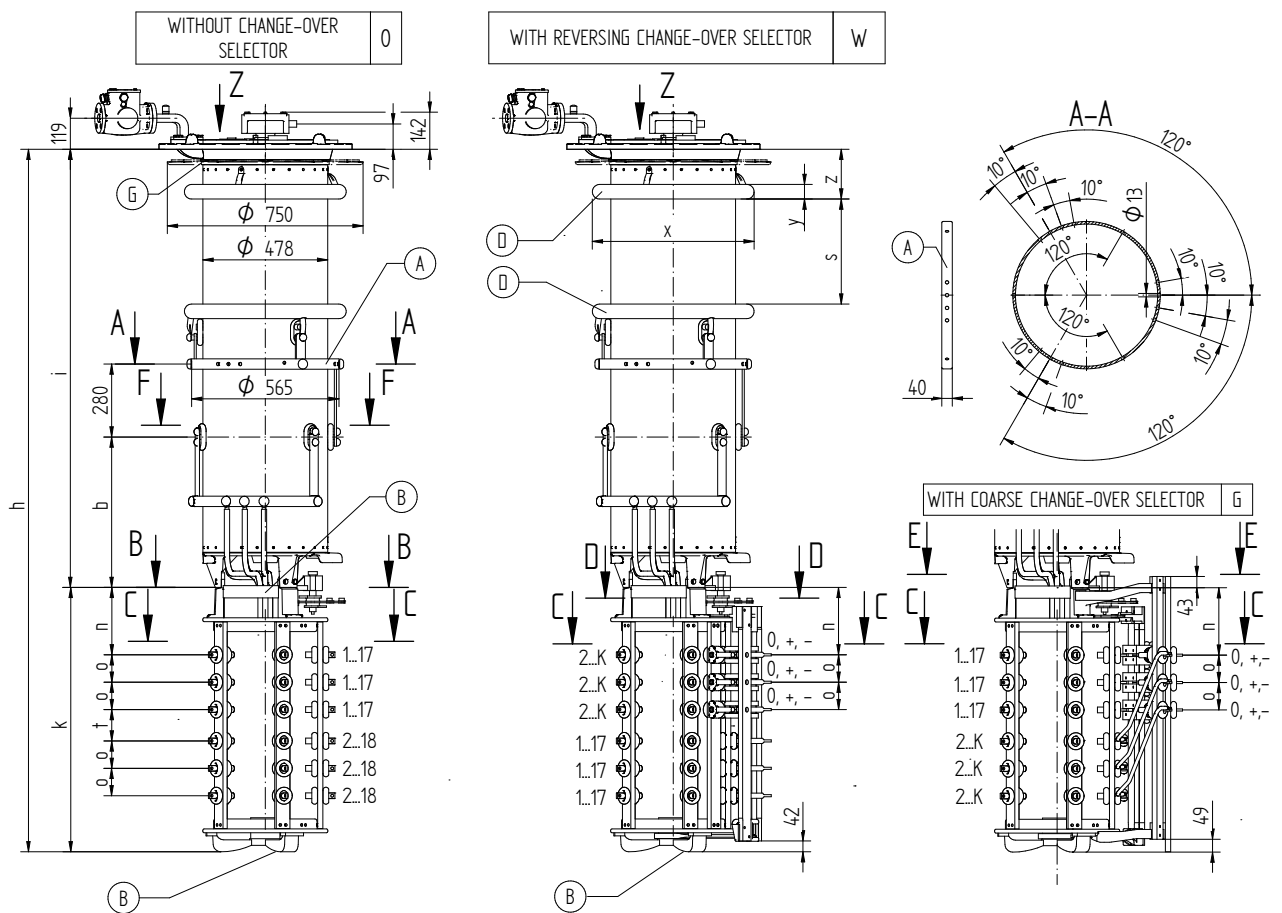

FOR THE TYPE OF THE OLTC-HEAD REFER TO THE ORDER-SPECIFIC DRAWING OF THE OLTC-HEAD AND DRIVE SHAFTS

- (M) - DRIVE SIDE OF SELECTOR
- (A) - ON-LOAD TAP-CHANGER CURRENT TAKE-OFF TERMINAL
- (B) - IS CONNECTED TO POTENTIAL OF (A)
- (D) - SHIELDING RINGS FOR UM OF 170 kV OR GREATER
- (G) - SUPPORTING FLANGE FOR THE BELL-TYPE TANK INSTALLATION IS OPTIONAL

- THE DETAILED CONNECTION DIAGRAM IS BINDING FOR THE DESIGNATION OF THE CONNECTION CONTACTS AND PHASES

- C-C: REFER TO 10018046

- D-D AND E-E: TYPE WITH CONNECTING LEAD 3W/3G REFER TO 723590

- CONNECTING OF PARALLEL SELECTOR PLANES REFER TO 10117014

© MASCHINENFABRIK REINHAUSEN GMBH 2018
 Weitergabe sowie Vervielfältigung dieses Dokuments, Verwertung und Mitteilung seines Inhaltes sind verboten, soweit nicht ausdrücklich gestattet.
 Zuwiderhandlungen verpflichten zu Schadenersatz. Alle Rechte für den Fall der Patent-, Gebrauchsmuster- oder Designeintragung vorbehalten.

VACUTAP® VRS

SELECTOR SIZE		B							C							D/DE						
Um [kV]		72,5	123	170	245	300	362	420	72,5	123	170	245	300	362	420	72,5	123	170	245	300	362	420
DIMENSIONS [mm]	h	2106	2236	2366	2466	2618	2721	2840	2181	2311	2441	2541	2693	2796	2915	2376	2506	2636	2736	2888	2991	3110
	i	1168	1298	1428	1528	1680	1783	1902	1168	1298	1428	1528	1680	1783	1902	1168	1298	1428	1528	1680	1783	1902
	b	425							425							425						
	s	-	-	302	402	554	573	692	-	-	302	402	554	573	692	-	-	302	402	554	573	692
	z	-	-	191	191	191	228	228	-	-	191	191	191	228	228	-	-	191	191	191	228	228
	x	-	-	∅ 620	∅ 620	∅ 620	∅ 695	∅ 695	-	-	∅ 620	∅ 620	∅ 620	∅ 695	∅ 695	-	-	∅ 620	∅ 620	∅ 620	∅ 695	∅ 695
	y	-	-	∅ 56	∅ 56	∅ 56	∅ 100	∅ 100	-	-	∅ 56	∅ 56	∅ 56	∅ 100	∅ 100	-	-	∅ 56	∅ 56	∅ 56	∅ 100	∅ 100
	k	938							1013							1208						
	n	233							258							323						
	o	105							105							105						
t	95							120							185							
OIL VOLUME [dm³]		160	180	200	220	240	260	280	160	180	200	220	240	260	280	160	180	200	220	240	260	280
DISPLACEMENT [dm³]		265	285	315	335	365	405	425	265	285	315	335	365	405	425	269	289	319	339	369	409	429
MAX. WEIGHT [kg]		337	343	356	359	365	372	377	347	353	366	369	375	382	387	363	369	382	385	391	398	403

VACUTAP® VRM

SELECTOR SIZE		B							C							D/DE						
Um [kV]		72,5	123	170	245	300	362	420	72,5	123	170	245	300	362	420	72,5	123	170	245	300	362	420
DIMENSIONS [mm]	h	2258	2388	2518	2618	2770	2873	2992	2333	2463	2593	2693	2845	2948	3067	2528	2658	2788	2888	3040	3143	3262
	i	1320	1450	1580	1680	1832	1935	2054	1320	1450	1580	1680	1832	1935	2054	1320	1450	1580	1680	1832	1935	2054
	b	576							576							576						
	s	-	-	302	402	554	573	692	-	-	302	402	554	573	692	-	-	302	402	554	573	692
	z	-	-	191	191	191	228	228	-	-	191	191	191	228	228	-	-	191	191	191	228	228
	x	-	-	∅ 620	∅ 620	∅ 620	∅ 695	∅ 695	-	-	∅ 620	∅ 620	∅ 620	∅ 695	∅ 695	-	-	∅ 620	∅ 620	∅ 620	∅ 695	∅ 695
	y	-	-	∅ 56	∅ 56	∅ 56	∅ 100	∅ 100	-	-	∅ 56	∅ 56	∅ 56	∅ 100	∅ 100	-	-	∅ 56	∅ 56	∅ 56	∅ 100	∅ 100
	k	938							1013							1208						
	n	233							258							323						
	o	105							105							105						
t	95							120							185							
OIL VOLUME [dm³]		180	200	230	245	270	285	305	180	200	230	245	270	285	305	180	200	230	245	270	285	305
DISPLACEMENT [dm³]		285	315	345	365	395	435	455	285	315	345	365	395	435	455	289	319	349	369	399	439	459
MAX. WEIGHT [kg]		346	352	365	369	374	381	386	356	362	375	379	384	391	396	372	378	391	395	400	407	412

Datum	Name		Dokumentnummer	
	16.05.2018	RAEDLINGER	SED 6018611 001 01	
	16.05.2018	HAUER	Änderungsnummer	Maßstab
Norm.	16.05.2018	PRODASTSCHUK	1087395	1:10

Maßangaben
in mm, soweit
nicht anders
angegeben



ON-LOAD TAP-CHANGER VACUTAP® VR
 VRS/VRM I 1301 - 72,5...420 kV - B/C/D/DE
 DIMENSION DRAWING

Serialnummer	
Materialnummer	Blatt
101169860E	2/2

© MASCHINENFABRIK REINHAUSEN GMBH 2018
 THE REPRODUCTION, DISTRIBUTION AND UTILIZATION OF THIS DOCUMENT AS WELL AS THE COMMUNICATION OF ITS CONTENTS TO OTHERS WITHOUT EXPRESS AUTHORIZATION IS PROHIBITED. OFFENDERS WILL BE HELD LIABLE FOR THE PAYMENT OF DAMAGES. ALL RIGHTS RESERVED IN THE EVENT OF A PATENT, UTILITY MODEL OR DESIGN.

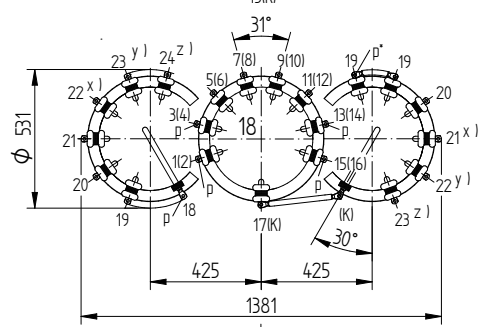
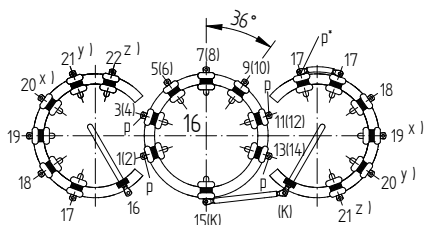
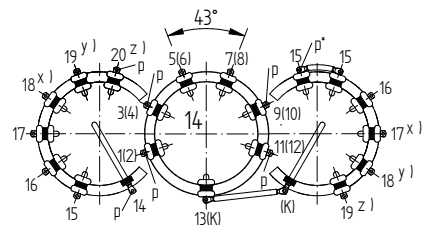
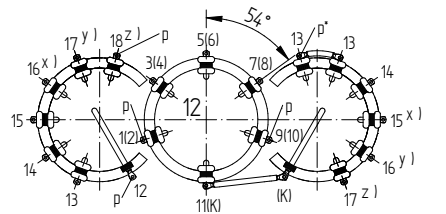
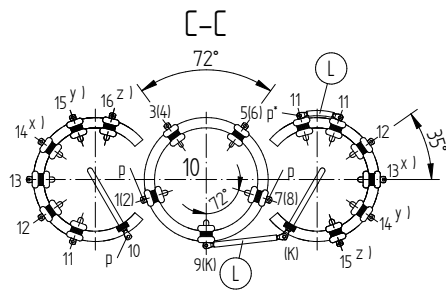
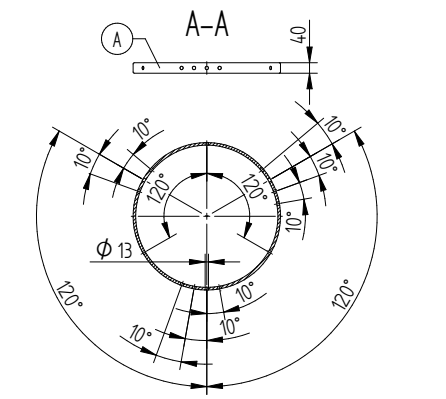
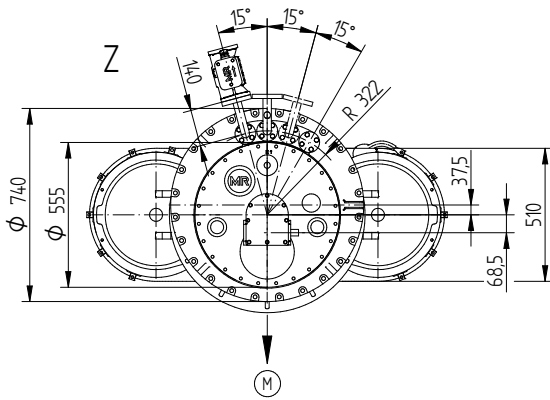
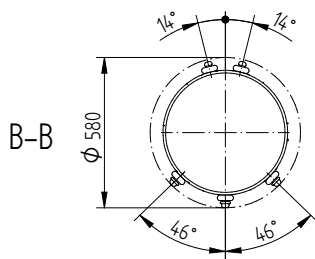
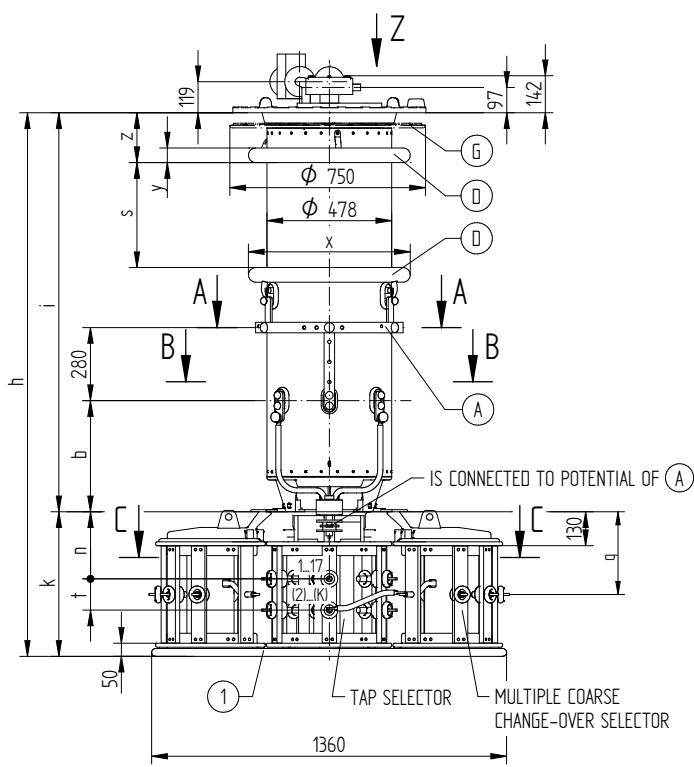

FOR THE TYPE OF OLTC-HEAD REFER TO THE ORDER-SPECIFIC DRAWING OF THE OLTC-HEAD AND DRIVE SHAFTS

- Ⓜ - DRIVE SIDE OF SELECTOR
- Ⓐ - ON-LOAD TAP-CHANGER CURRENT TAKE-OFF TERMINAL
- ⓓ - SHIELDING RINGS FOR UM OF 170 KV OR GREATER
- ⓖ - SUPPORTING FLANGE FOR THE BELL-TYPE TANK INSTALLATION IS OPTIONAL
- ① - BOTTOM-MOST LIVE PARTS; THESE ARE CONNECTED TO THE POTENTIAL OF THE ASSOCIATED AND/OR WIRED CONNECTION CONTACT

- THE DETAILED CONNECTION DIAGRAM IS BINDING FOR THE DESIGNATION OF THE CONNECTION CONTACTS AND PHASES

ARRANGEMENT OF SELECTOR CONTACTS, 2-5 COARSE TAP CONNECTIONS

- x) FOR 3 COARSE TAP CONNECTIONS
- x) AND y) FOR 4 COARSE TAP CONNECTIONS
- x), y) AND z) FOR 5 COARSE TAP CONNECTIONS

p = CONNECTION MIN. 3 MM PAPER INSULATED
 p* = CONNECTION ALREADY 3 MM PAPER INSULATED BY MR

DOCUMENT NO.	NAME	DATE
SED 5550262 001 02	RAEDLINGER	19.04.2018
SCALE	HAUER	25.04.2018
1:10	PRODASTSCHUK	25.04.2018
CHANGE NO.		
1087395		

DIMENSION IN mm EXCEPT AS NOTED



ON-LOAD TAP-CHANGER VACUTAP® VR
 VRS/VRM I 701 -72,5...300kV- B/C/D WITH MULTIPLE COARSE COS
 DIMENSION DRAWING

SERIAL NUMBER

MATERIAL NUMBER	SHEET
100208541E	1/2

VACUTAP® VRS I 701

SELECTOR SIZE		B					C					D				
Um [kV]		72,5	123	170	245	300	72,5	123	170	245	300	72,5	123	170	245	300
DIMENSIONS [mm]	h	1648	1778	1908	2008	2160	1723	1853	1983	2083	2235	1918	2048	2178	2278	2430
	i	1168	1298	1428	1528	1680	1168	1298	1428	1528	1680	1168	1298	1428	1528	1680
	b	425					425					425				
	s	-	-	302	402	554	-	-	302	402	554	-	-	302	402	554
	Z	-	-	191	191	191	-	-	191	191	191	-	-	191	191	191
	x	-	-	∅ 620	∅ 620	∅ 620	-	-	∅ 620	∅ 620	∅ 620	-	-	∅ 620	∅ 620	∅ 620
	y	-	-	∅ 56	∅ 56	∅ 56	-	-	∅ 56	∅ 56	∅ 56	-	-	∅ 56	∅ 56	∅ 56
	k	480					555					750				
	n	233					258					323				
	t	95					120					185				
q	279,5					317					414,5					
OIL VOLUME [dm³]		160	180	200	220	240	160	180	200	220	240	160	180	200	220	240
DISPLACEMENT [dm³]		254	274	304	324	354	255	275	305	325	355	257	277	307	327	357
MAX. WEIGHT [kg]		402	408	421	424	430	412	418	431	434	440	422	428	441	444	450

VACUTAP® VRM I 701

SELECTOR SIZE		B					C					D				
Um [kV]		72,5	123	170	245	300	72,5	123	170	245	300	72,5	123	170	245	300
DIMENSIONS [mm]	h	1800	1930	2060	2160	2312	1875	2005	2135	2235	2387	2070	2200	2330	2430	2582
	i	1320	1450	1580	1680	1832	1320	1450	1580	1680	1832	1320	1450	1580	1680	1832
	b	576					576					576				
	s	-	-	302	402	554	-	-	302	402	554	-	-	302	402	554
	Z	-	-	191	191	191	-	-	191	191	191	-	-	191	191	191
	x	-	-	∅ 620	∅ 620	∅ 620	-	-	∅ 620	∅ 620	∅ 620	-	-	∅ 620	∅ 620	∅ 620
	y	-	-	∅ 56	∅ 56	∅ 56	-	-	∅ 56	∅ 56	∅ 56	-	-	∅ 56	∅ 56	∅ 56
	k	480					555					750				
	n	233					258					323				
	t	95					120					185				
q	279,5					317					414,5					
OIL VOLUME [dm³]		180	200	230	245	270	180	200	230	245	270	180	200	230	245	270
DISPLACEMENT [dm³]		284	304	334	354	384	285	305	335	355	385	287	307	337	357	387
MAX. WEIGHT [kg]		411	417	430	433	439	421	427	440	443	449	431	437	450	453	459

DATE	NAME	DOCUMENT NO.
19.04.2018	RAEDLINGER	SED 5550262.001 02
25.04.2018	HAUER	CHANGE NO.
25.04.2018	PRODASTSCHUK	1087395
DFTR.	SCALE	1:10
CHKD.		
STAND.		

DIMENSION
IN mm
EXCEPT AS
NOTED



ON-LOAD TAP-CHANGER VACUTAP® VR
 VRS/VRM I 701 -72,5...300kV- B/C/D WITH MULTIPLE COARSE COS
 DIMENSION DRAWING

SERIAL NUMBER

MATERIAL NUMBER	SHEET
100208541E	2/2

MASCHINENFABRIK REINHAUSEN GMBH 2018
 THE REPRODUCTION, DISTRIBUTION AND UTILIZATION OF THIS DOCUMENT AS WELL AS THE COMMUNICATION OF ITS CONTENTS TO OTHERS WITHOUT EXPRESS AUTHORIZATION IS PROHIBITED. OFFENDERS WILL BE HELD LIABLE FOR THE PAYMENT OF DAMAGES. ALL RIGHTS RESERVED IN THE EVENT OF A PATENT, UTILITY MODEL OR DESIGN.

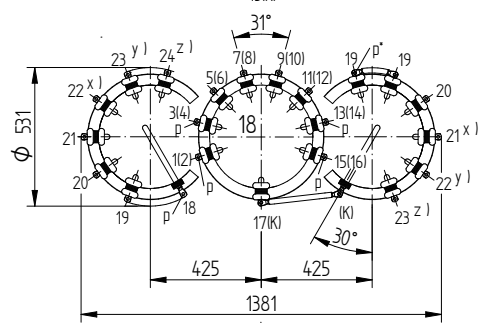
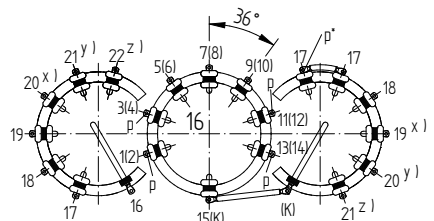
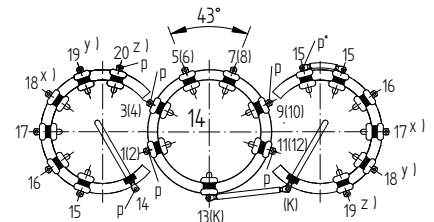
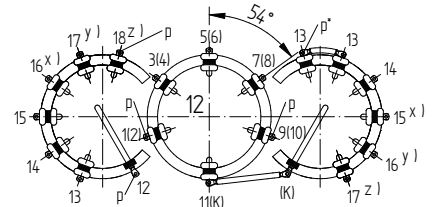
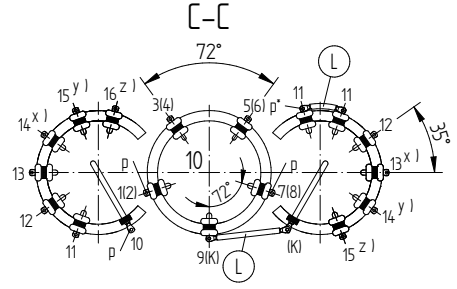
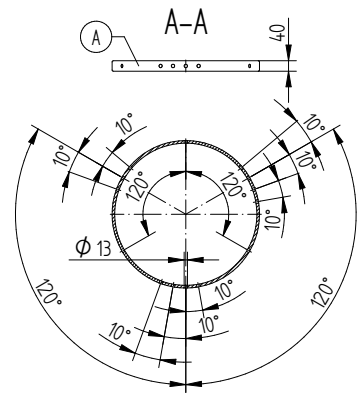
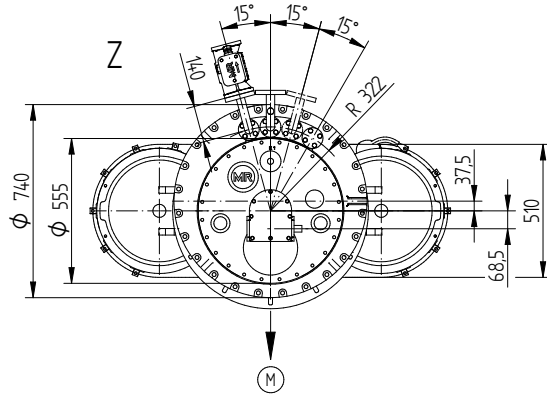
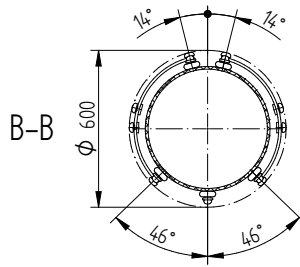
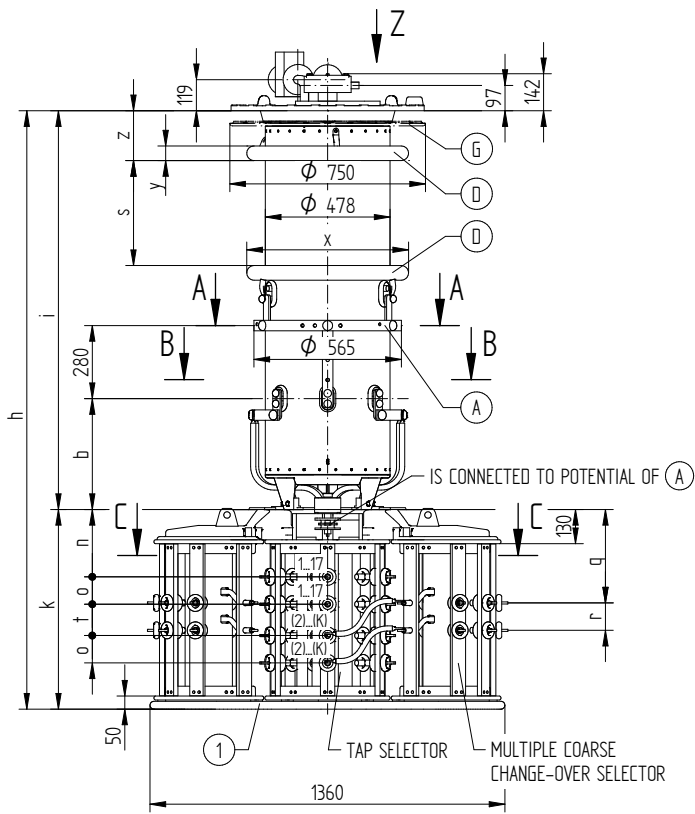

FOR THE TYPE OF OLTC-HEAD REFER TO THE ORDER-SPECIFIC DRAWING OF THE OLTC-HEAD AND DRIVE SHAFTS

- (M) - DRIVE SIDE OF SELECTOR
- (A) - ON-LOAD TAP-CHANGER CURRENT TAKE-OFF TERMINAL
- (D) - SHIELDING RINGS FOR UM OF 170 KV OR GREATER
- (G) - SUPPORTING FLANGE FOR THE BELL-TYPE TANK INSTALLATION IS OPTIONAL

- (1) - BOTTOM-MOST LIVE PARTS; THESE ARE CONNECTED TO THE POTENTIAL OF THE ASSOCIATED AND/OR WIRED CONNECTION CONTACT

- THE DETAILED CONNECTION DIAGRAM IS BINDING FOR THE DESIGNATION OF THE CONNECTION CONTACTS AND PHASES
- CONNECTING OF PARALLEL SELECTOR PLANES REFER TO 10117014

ARRANGEMENT OF SELECTOR CONTACTS, 2-5 COARSE TAP CONNECTIONS

- x) FOR 3 COARSE TAP CONNECTIONS
- x) AND y) FOR 4 COARSE TAP CONNECTIONS
- x), y) AND z) FOR 5 COARSE TAP CONNECTIONS

- p = CONNECTION MIN. 3 MM PAPER INSULATED
- p* = CONNECTION ALREADY 3 MM PAPER INSULATED BY MR

DOCUMENT NO.	SED 5550268 001 02	
NAME	RAEDLINGER	HAUER
DATE	19.04.2018	25.04.2018
DFTR.	CHKD.	STAND.
SCALE	1:10	
CHANGE NO.	1087395	
PRODASTSCHUK		

DIMENSION IN mm EXCEPT AS NOTED



ON-LOAD TAP-CHANGER VACUTAP® VR
 VRS/VRM I 1001 - 72,5...300kV-B/C/D WITH MULTIPLE COARSE COS
 DIMENSION DRAWING

SERIAL NUMBER	
MATERIAL NUMBER	100208551E
SHEET	1/2

VACUTAP® VRS I 1001

SELECTOR SIZE		B					C					D				
Um [kV]		72,5	123	170	245	300	72,5	123	170	245	300	72,5	123	170	245	300
DIMENSIONS [mm]	h	1858	1988	2118	2218	2370	1933	2063	2193	2293	2445	2128	2258	2388	2488	2640
	i	1168	1298	1428	1528	1680	1168	1298	1428	1528	1680	1168	1298	1428	1528	1680
	b	425					425					425				
	s	-	-	302	402	554	-	-	302	402	554	-	-	302	402	554
	z	-	-	191	191	191	-	-	191	191	191	-	-	191	191	191
	x	-	-	∅ 620	∅ 620	∅ 620	-	-	∅ 620	∅ 620	∅ 620	-	-	∅ 620	∅ 620	∅ 620
	y	-	-	∅ 56	∅ 56	∅ 56	-	-	∅ 56	∅ 56	∅ 56	-	-	∅ 56	∅ 56	∅ 56
	k	690					765					960				
	n	233					258					323				
	o	105					105					105				
	t	95					120					185				
	r	105					105					105				
	q	319,5					357					454,5				
OIL VOLUME [dm³]		160	180	200	220	240	160	180	200	220	240	160	180	200	220	240
DISPLACEMENT [dm³]		265	285	315	335	365	267	287	317	337	367	270	290	320	340	370
MAX. WEIGHT [kg]		436	442	455	458	464	446	452	465	468	474	456	462	475	478	484

VACUTAP® VRM I 1001

SELECTOR SIZE		B					C					D				
Um [kV]		72,5	123	170	245	300	72,5	123	170	245	300	72,5	123	170	245	300
DIMENSIONS [mm]	h	2010	2140	2270	2370	2522	2085	2215	2345	2445	2597	2280	2410	2540	2640	2792
	i	1320	1450	1580	1680	1832	1320	1450	1580	1680	1832	1320	1450	1580	1680	1832
	b	576					576					576				
	s	-	-	302	402	554	-	-	302	402	554	-	-	302	402	554
	z	-	-	191	191	191	-	-	191	191	191	-	-	191	191	191
	x	-	-	∅ 620	∅ 620	∅ 620	-	-	∅ 620	∅ 620	∅ 620	-	-	∅ 620	∅ 620	∅ 620
	y	-	-	∅ 56	∅ 56	∅ 56	-	-	∅ 56	∅ 56	∅ 56	-	-	∅ 56	∅ 56	∅ 56
	k	690					765					960				
	n	233					258					323				
	o	105					105					105				
	t	95					120					185				
	r	105					105					105				
	q	319,5					357					454,5				
OIL VOLUME [dm³]		180	200	230	245	270	180	200	230	245	270	180	200	230	245	270
DISPLACEMENT [dm³]		295	315	345	365	395	297	317	347	367	397	300	320	350	370	400
MAX. WEIGHT [kg]		447	453	466	469	475	457	463	476	479	485	467	473	486	489	495

DATE	NAME	DOCUMENT NO.
19.04.2018	RAEDLINGER	SED 5550268 001 02
25.04.2018	HAUER	CHANGE NO.
25.04.2018	PRODASTSCHUK	1087395
DFTR.	SCALE	1:10
CHKD.		
STAND.		

DIMENSION
IN mm
EXCEPT AS
NOTED



ON-LOAD TAP-CHANGER VACUTAP® VR
 VRS/VRM I 1001 -72,5...300kV-B/C/D WITH MULTIPLE COARSE COS
 DIMENSION DRAWING

SERIAL NUMBER

MATERIAL NUMBER	SHEET
100208551E	2/2

MASCHINENFABRIK REINHAUSEN GMBH 2018
 THE REPRODUCTION, DISTRIBUTION AND UTILIZATION OF THIS DOCUMENT AS WELL AS THE COMMUNICATION OF ITS CONTENTS TO OTHERS WITHOUT EXPRESS AUTHORIZATION IS PROHIBITED. OFFENDERS WILL BE HELD LIABLE FOR THE PAYMENT OF DAMAGES. ALL RIGHTS RESERVED IN THE EVENT OF A PATENT, UTILITY MODEL OR DESIGN.

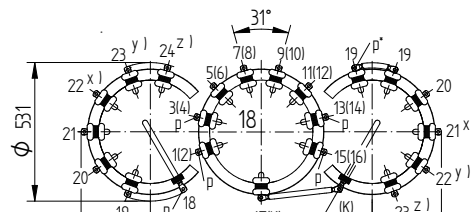
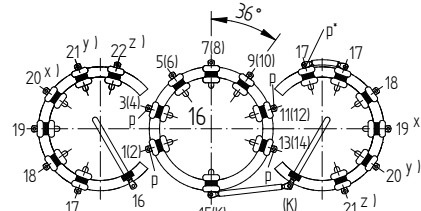
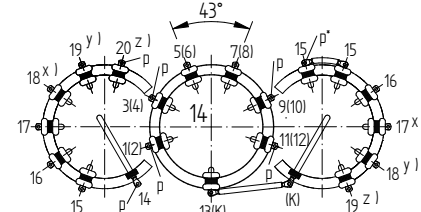
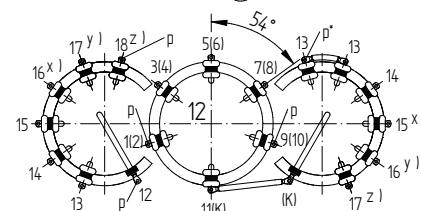
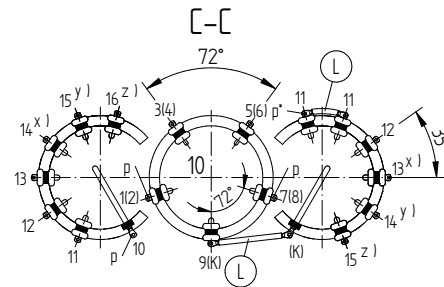
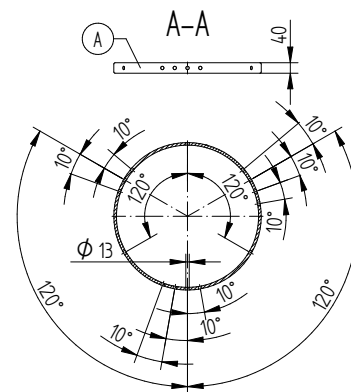
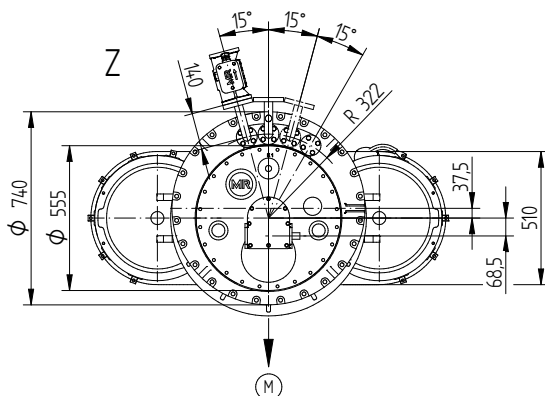
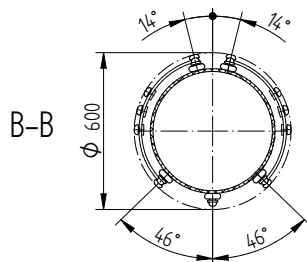
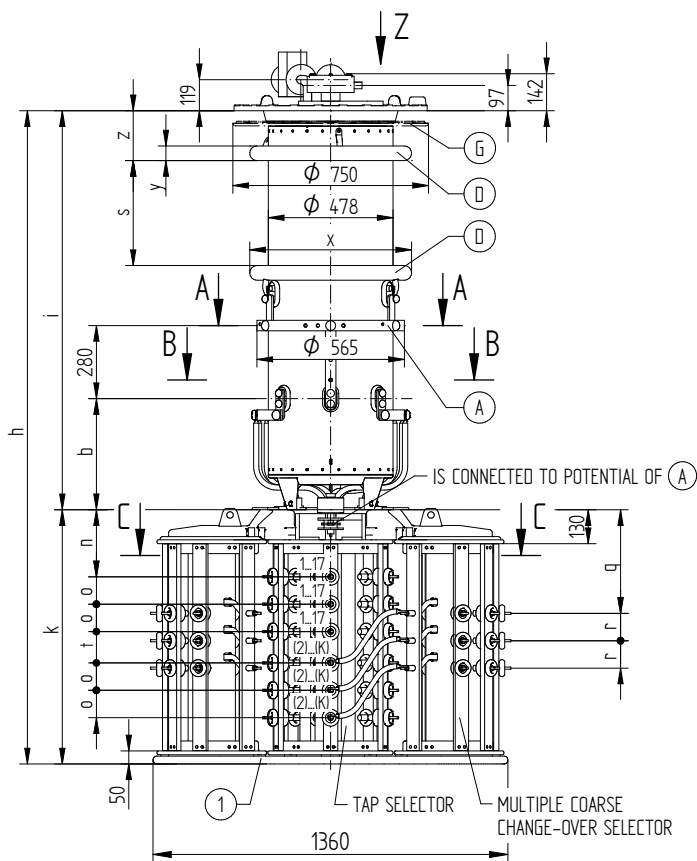

FOR THE TYPE OF OLTC-HEAD REFER TO THE ORDER-SPECIFIC DRAWING OF THE OLTC-HEAD AND DRIVE SHAFTS

- (M) - DRIVE SIDE OF SELECTOR
- (A) - ON-LOAD TAP-CHANGER CURRENT TAKE-OFF TERMINAL
- (D) - SHIELDING RINGS FOR UM OF 170 KV OR GREATER
- (G) - SUPPORTING FLANGE FOR THE BELL-TYPE TANK INSTALLATION IS OPTIONAL

(1) - BOTTOM-MOST LIVE PARTS; THESE ARE CONNECTED TO THE POTENTIAL OF THE ASSOCIATED AND/OR WIRED CONNECTION CONTACT

- THE DETAILED CONNECTION DIAGRAM IS BINDING FOR THE DESIGNATION OF THE CONNECTION CONTACTS AND PHASES

- CONNECTING OF PARALLEL SELECTOR PLANES REFER TO 10117014

ARRANGEMENT OF SELECTOR CONTACTS, 2-5 COARSE TAP CONNECTIONS

- x) FOR 3 COARSE TAP CONNECTIONS
- x) AND y) FOR 4 COARSE TAP CONNECTIONS
- x), y) AND z) FOR 5 COARSE TAP CONNECTIONS

p = CONNECTION MIN. 3 MM PAPER INSULATED
 p* = CONNECTION ALREADY 3 MM PAPER INSULATED BY MR

DOCUMENT NO.	SED 5550283 001 02
NAME	RAEDLINGER HAUER
DATE	19.04.2018
CHKD.	25.04.2018
SCALE	1:10
STAND.	25.04.2018
CHANGE NO.	1087395
PRODASTSCHUK	

DIMENSION IN mm EXCEPT AS NOTED



ON-LOAD TAP-CHANGER VACUTAP® VR
 VRS/VRM I 1301 - 72,5...300kV-B/C/D WITH MULTIPLE COARSE COS
 DIMENSION DRAWING

SERIAL NUMBER

MATERIAL NUMBER 100208561E
 SHEET 1/2

VACUTAP® VRS I 1301

SELECTOR SIZE		B					C					D				
Um [kV]		72,5	123	170	245	300	72,5	123	170	245	300	72,5	123	170	245	300
DIMENSIONS [mm]	h	2068	2198	2328	2428	2580	2143	2273	2403	2503	2655	2338	2468	2598	2698	2850
	i	1168	1298	1428	1528	1680	1168	1298	1428	1528	1680	1168	1298	1428	1528	1680
	b	425					425					425				
	s	-	-	302	402	554	-	-	302	402	554	-	-	302	402	554
	z	-	-	191	191	191	-	-	191	191	191	-	-	191	191	191
	x	-	-	∅ 620	∅ 620	∅ 620	-	-	∅ 620	∅ 620	∅ 620	-	-	∅ 620	∅ 620	∅ 620
	y	-	-	∅ 56	∅ 56	∅ 56	-	-	∅ 56	∅ 56	∅ 56	-	-	∅ 56	∅ 56	∅ 56
	k	900					975					1170				
	n	233					258					323				
	o	105					105					105				
	t	95					120					185				
	r	105					105					105				
	q	359,5					397					494,5				
OIL VOLUME [dm³]		160	180	200	220	240	160	180	200	220	240	160	180	200	220	240
DISPLACEMENT [dm³]		277	297	327	347	377	279	299	329	349	379	282	302	332	352	382
MAX. WEIGHT [kg]		486	492	505	508	514	496	502	515	518	524	506	512	525	528	534

VACUTAP® VRM I 1301

SELECTOR SIZE		B					C					D				
Um [kV]		72,5	123	170	245	300	72,5	123	170	245	300	72,5	123	170	245	300
DIMENSIONS [mm]	h	2220	2350	2480	2580	2732	2295	2425	2555	2655	2807	2490	2620	2750	2850	3002
	i	1320	1450	1580	1680	1832	1320	1450	1580	1680	1832	1320	1450	1580	1680	1832
	b	576					576					576				
	s	-	-	302	402	554	-	-	302	402	554	-	-	302	402	554
	z	-	-	191	191	191	-	-	191	191	191	-	-	191	191	191
	x	-	-	∅ 620	∅ 620	∅ 620	-	-	∅ 620	∅ 620	∅ 620	-	-	∅ 620	∅ 620	∅ 620
	y	-	-	∅ 56	∅ 56	∅ 56	-	-	∅ 56	∅ 56	∅ 56	-	-	∅ 56	∅ 56	∅ 56
	k	900					975					1170				
	n	233					258					323				
	o	105					105					105				
	t	95					120					185				
	r	105					105					105				
	q	359,5					397					494,5				
OIL VOLUME [dm³]		180	200	230	245	270	180	200	230	245	270	180	200	230	245	270
DISPLACEMENT [dm³]		307	327	357	377	407	309	329	359	379	409	312	332	362	382	412
MAX. WEIGHT [kg]		497	503	516	519	525	507	513	526	529	535	517	523	536	539	545

DATE	NAME	DOCUMENT NO.
19.04.2018	RAEDLINGER	SED 5550283_001 02
25.04.2018	HAUER	CHANGE NO.
25.04.2018	PRODASTSCHUK	1087395
DFTR.	SCALE	1:10

DIMENSION
IN mm
EXCEPT AS
NOTED



ON-LOAD TAP-CHANGER VACUTAP® VR
 VRS/VRM I 1301 -72,5...300kV-B/C/D WITH MULTIPLE COARSE COS
 DIMENSION DRAWING

SERIAL NUMBER

MATERIAL NUMBER	SHEET
100208561E	2/2

© MASCHINENFABRIK REINHAUSEN GMBH 2018
 THE REPRODUCTION, DISTRIBUTION AND UTILIZATION OF THIS DOCUMENT AS WELL AS THE COMMUNICATION OF ITS CONTENTS TO OTHERS WITHOUT EXPRESS AUTHORIZATION IS PROHIBITED. OFFENDERS WILL BE HELD LIABLE FOR THE PAYMENT OF DAMAGES. ALL RIGHTS RESERVED IN THE EVENT OF THE GRANT OF A PATENT, UTILITY MODEL OR DESIGN.

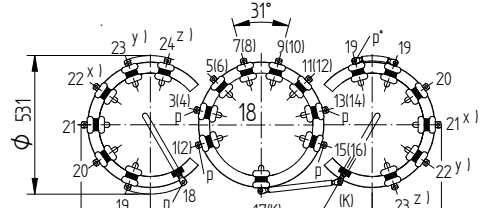
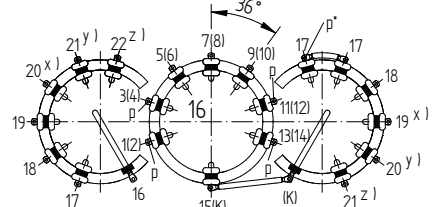
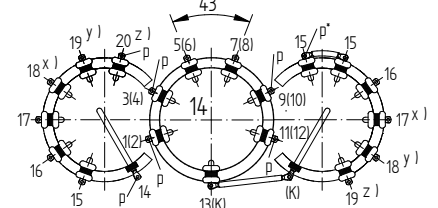
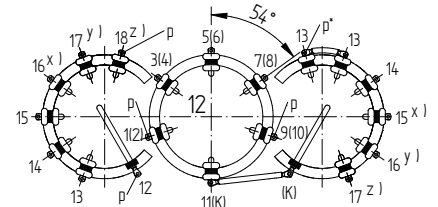
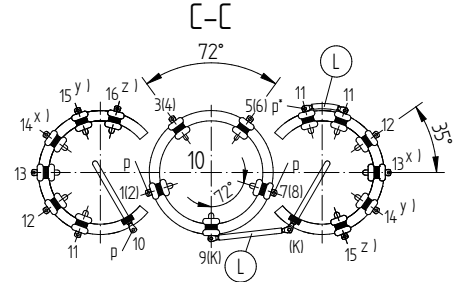
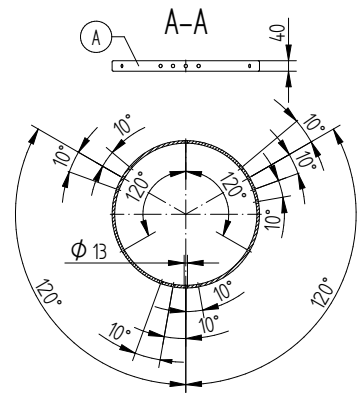
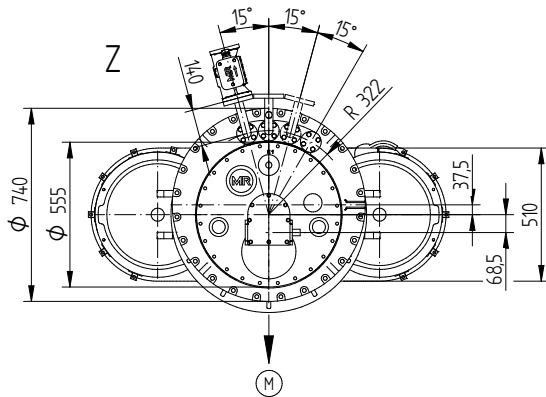
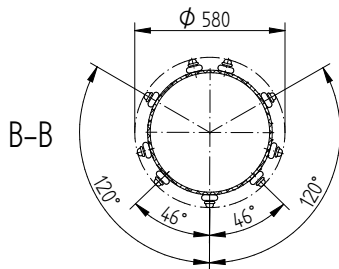
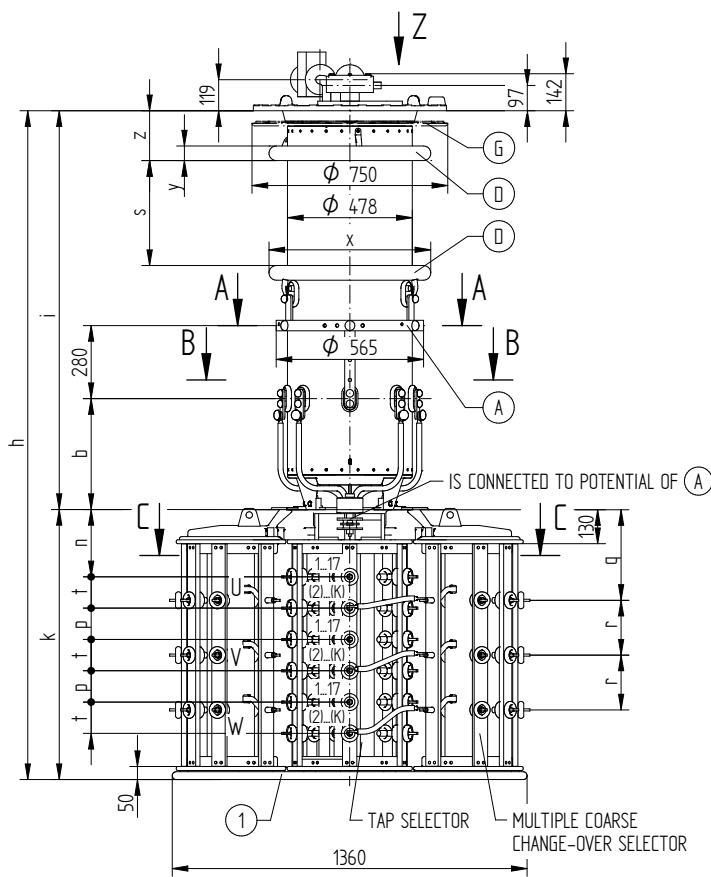

FOR THE TYPE OF OLTC-HEAD REFER TO THE ORDER-SPECIFIC DRAWING OF THE OLTC-HEAD AND DRIVE SHAFTS

- (M) - DRIVE SIDE OF SELECTOR
- (A) - ON-LOAD TAP-CHANGER CURRENT TAKE-OFF TERMINAL
- (D) - SHIELDING RINGS FOR UM OF 170 KV OR GREATER
- (G) - SUPPORTING FLANGE FOR THE BELL-TYPE TANK INSTALLATION IS OPTIONAL

- (1) - BOTTOM-MOST LIVE PARTS; THESE ARE CONNECTED TO THE POTENTIAL OF THE ASSOCIATED AND/OR WIRED CONNECTION CONTACT

- THE DETAILED CONNECTION DIAGRAM IS BINDING FOR THE DESIGNATION OF THE CONNECTION CONTACTS AND PHASES

ARRANGEMENT OF SELECTOR CONTACTS, 2-5 COARSE TAP CONNECTIONS

- x) FOR 3 COARSE TAP CONNECTIONS
- x) AND y) FOR 4 COARSE TAP CONNECTIONS
- x), y) AND z) FOR 5 COARSE TAP CONNECTIONS

p = CONNECTION MIN. 3 MM PAPER INSULATED
 p* = CONNECTION ALREADY 3 MM PAPER INSULATED BY MR

DOCUMENT NO.	SED 5550295 001 02
NAME	RAEDLINGER HAUER
DATE	19.04.2018
DFTR.	25.04.2018
CHKD.	25.04.2018
SCALE	1:10
CHANGE NO.	1087395
PRODASTSCHUK	

DIMENSION IN mm EXCEPT AS NOTED



ON-LOAD TAP-CHANGER VACUTAP® VR
 VRS/VRMIII 700 Y-72,5...245kV- B/C/D WITH MULT.COARSE COS
 DIMENSION DRAWING

SERIAL NUMBER

MATERIAL NUMBER 100208571E
 SHEET 1/2

VACUTAP® VRS III 700 Y

SELECTOR SIZE		B				C				D			
Um [kV]		72,5	123	170	245	72,5	123	170	245	72,5	123	170	245
DIMENSIONS [mm]	h	2028	2158	2288	2388	2203	2333	2463	2563	2658	2788	2918	3018
	i	1168	1298	1428	1528	1168	1298	1428	1528	1168	1298	1428	1528
	b	425				425				425			
	s	-	-	302	402	-	-	302	402	-	-	302	402
	z	-	-	191	191	-	-	191	191	-	-	191	191
	x	-	-	∅ 620	∅ 620	-	-	∅ 620	∅ 620	-	-	∅ 620	∅ 620
	y	-	-	∅ 56	∅ 56	-	-	∅ 56	∅ 56	-	-	∅ 56	∅ 56
	k	860				1035				1490			
	n	233				258				323			
	p	95				120				185			
	t	95				120				185			
	r	166,5				210				327			
q	303				347				457,5				
OIL CONTENT [dm³]	150	170	190	210	150	170	190	210	150	170	190	210	
DISPLACEMENT [dm³]	275	295	325	345	281	301	331	351	290	310	340	360	
MAX. WEIGHT [kg]	532	538	550	554	542	548	560	564	552	558	570	574	

VACUTAP® VRM III 700 Y

SELECTOR SIZE		B				C				D			
Um [kV]		72,5	123	170	245	72,5	123	170	245	72,5	123	170	245
DIMENSIONS [mm]	h	2180	2310	2440	2540	2355	2485	2615	2715	2810	2940	3070	3170
	i	1320	1450	1580	1680	1320	1450	1580	1680	1320	1450	1580	1680
	b	576				576				576			
	s	-	-	302	402	-	-	302	402	-	-	302	402
	z	-	-	191	191	-	-	191	191	-	-	191	191
	x	-	-	∅ 620	∅ 620	-	-	∅ 620	∅ 620	-	-	∅ 620	∅ 620
	y	-	-	∅ 56	∅ 56	-	-	∅ 56	∅ 56	-	-	∅ 56	∅ 56
	k	860				1035				1490			
	n	233				258				323			
	p	95				120				185			
	t	95				120				185			
	r	166,5				210				327			
q	303				347				457,5				
OIL VOLUME [dm³]	170	190	210	235	170	190	210	235	170	190	210	235	
DISPLACEMENT [dm³]	305	325	355	375	311	331	361	381	320	340	370	390	
MAX. WEIGHT [kg]	552	558	570	574	562	568	580	584	572	578	590	594	

DATE	NAME	DOCUMENT NO.
19.04.2018	RAEDLINGER	SED 5550295 001 02
25.04.2018	HAUER	CHANGE NO.
25.04.2018	PRODASTSCHUK	1087395
DFTR.	SCALE	1:10
CHKD.		
STAND.		

DIMENSION
IN mm
EXCEPT AS
NOTED



ON-LOAD TAP-CHANGER VACUTAP® VR
VRS/VRMIII 700 Y-72,5...245kV- B/C/D WITH MULT.COARSE COS
DIMENSION DRAWING

SERIAL NUMBER

MATERIAL NUMBER	SHEET
100208571E	2/2

MASCHINENFABRIK REINHAUSEN GMBH COPYRIGHT RESERVED
 THE REPRODUCTION, DISTRIBUTION AND UTILIZATION OF THIS DOCUMENT AS WELL AS THE COMMUNICATION OF ITS CONTENTS TO OTHERS WITHOUT EXPRESS AUTHORIZATION IS PROHIBITED. OFFENDERS WILL BE HELD LIABLE FOR THE PAYMENT OF DAMAGES. ALL RIGHTS RESERVED IN THE EVENT OF THE GRANT OF A PATENT, UTILITY MODEL OR DESIGN.

DATE	NAME	DOCUMENT NO.
26.07.2022	BUTERUS	SED 8942283 001 00
27.07.2022	WREDE	CHANGE NO.
27.07.2022	KLEYN	1116192
DFTR.	SCALE	1:10
CHKD.		
STAND.		

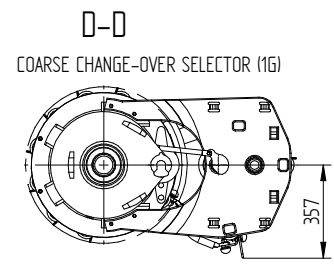
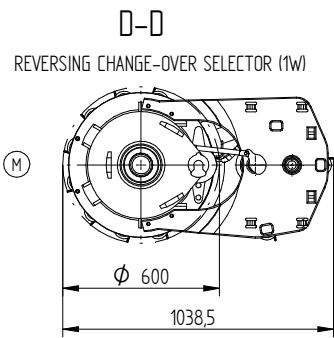
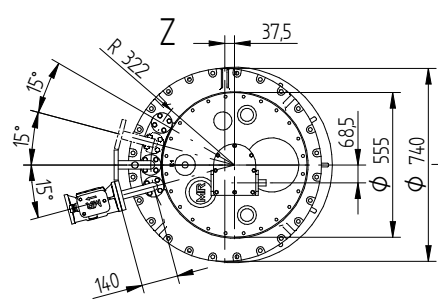
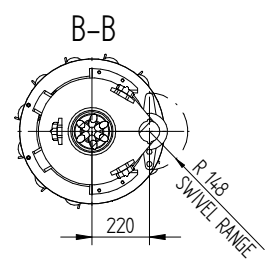
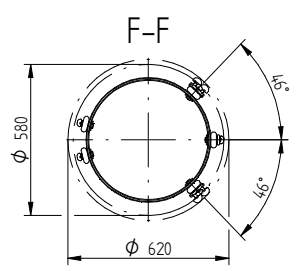
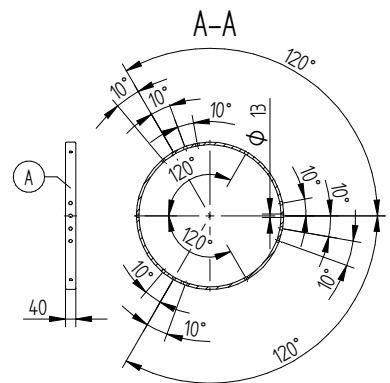
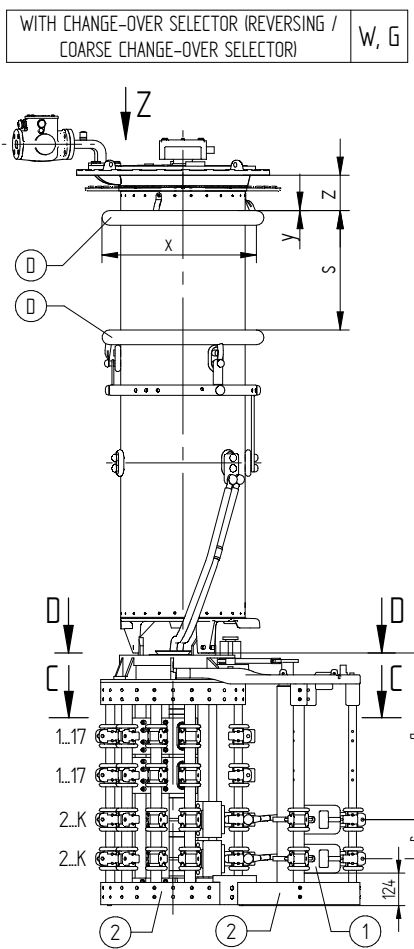
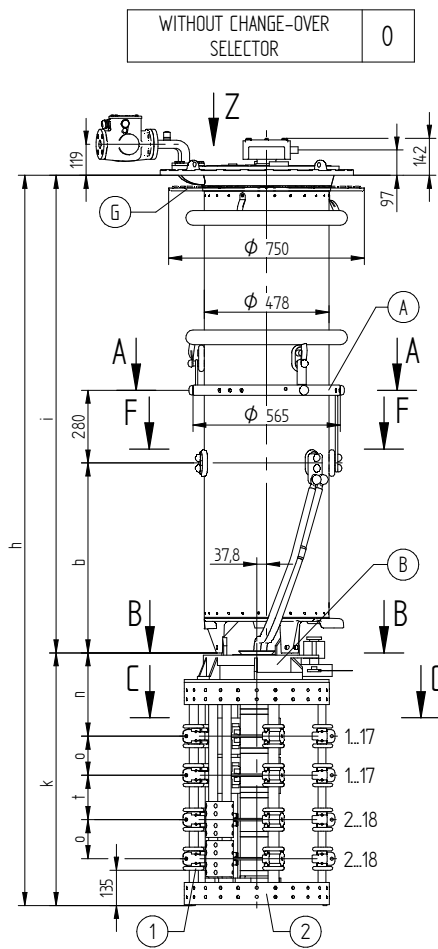

FOR THE TYPE OF OLTC-HEAD REFER TO THE ORDER-SPECIFIC DRAWING OF THE OLTC-HEAD AND DRIVE SHAFTS

- (M) - DRIVE SIDE OF SELECTOR
- (A) - ON-LOAD TAP-CHANGER CURRENT TAKE-OFF TERMINAL
- (B) - IS CONNECTED TO POTENTIAL OF (A)
- (D) - SHIELDING RINGS FOR UM OF 170 KV OR GREATER
- (G) - SUPPORTING FLANGE FOR THE BELL-TYPE TANK INSTALLATION IS OPTIONAL
- (1) - BOTTOM-MOST LIVE PARTS; THESE ARE CONNECTED TO THE POTENTIAL OF THE ASSOCIATED AND/OR WIRED CONNECTION CONTACT
- (2) - SELECTOR BASE IS MADE OF INSULATING MATERIAL

- THE DETAILED CONNECTION DIAGRAM IS BINDING FOR THE DESIGNATION OF THE CONNECTION CONTACTS AND PHASES
- C-C: REFER TO 10009030
- D-D: TYPE WITH CONNECTING LEAD 3W/3G REFER TO 10010019

DIMENSION IN mm EXCEPT AS NOTED



ON-LOAD TAP-CHANGER VACUTAP® VR®
 VRL I 1601 - 725 ... 420 kV - RC, RD/RDE
 DIMENSION DRAWING

SERIAL NUMBER

MATERIAL NUMBER	SHEET
101714710E	1/2

MASCHINENFABRIK REINHAUSEN GMBH COPYRIGHT RESERVED
 THE REPRODUCTION, DISTRIBUTION AND UTILIZATION OF THIS DOCUMENT AS WELL AS THE COMMUNICATION OF ITS CONTENTS TO OTHERS WITHOUT EXPRESS AUTHORIZATION IS PROHIBITED. OFFENDERS WILL BE HELD LIABLE FOR THE PAYMENT OF DAMAGES. ALL RIGHTS RESERVED IN THE EVENT OF THE GRANT OF A PATENT, UTILITY MODEL OR DESIGN.

DFTR.	DATE	NAME	DOCUMENT NO.
26.07.2022	26.07.2022	BUTERUS	SED 8942283 001 00
CHKD.	DATE	WREDE	CHANGE NO.
27.07.2022	27.07.2022	KLEYN	1116192
STAND.	DATE		SCALE
			1:10

SELECTOR SIZE		RC							RD / RDE						
Um [kV]		72,5	123	170	245	300	362	420	72,5	123	170	245	300	362	420
DIMENSIONS [mm]	h	2440	2570	2700	2800	2952	3055	3174	2520	2650	2780	2880	3032	3135	3254
	i	1471	1601	1731	1831	1983	2086	2205	1471	1601	1731	1831	1983	2086	2205
	b	728							728						
	s	-	-	302	402	554	573	692	-	-	302	402	554	573	692
	z	-	-	191	191	191	228	228	-	-	191	191	191	228	228
	x	-	-	∅ 620	∅ 620	∅ 620	∅ 695	∅ 695	-	-	∅ 620	∅ 620	∅ 620	∅ 695	∅ 695
	y	-	-	∅ 56	∅ 56	∅ 56	∅ 100	∅ 100	-	-	∅ 56	∅ 56	∅ 56	∅ 100	∅ 100
	k	969							1049						
	n	319							359						
	o	150							150						
	t	170							210						
	r	150							150						
	q	639							719						
OIL VOLUME [dm ³]		205	225	245	265	285	305	325	205	225	245	265	285	305	325
DISPLACEMENT [dm ³]		313	343	373	393	423	463	483	315	345	375	395	425	465	485
MAX. WEIGHT [kg]		479	485	497	501	507	514	519	484	490	502	506	512	519	524

DIMENSION
IN mm
EXCEPT AS
NOTED



ON-LOAD TAP-CHANGER VACUTAP® VR®
 VRL I 1601 - 72,5 ... 420 kV - RC, RD/RDE
 DIMENSION DRAWING

SERIAL NUMBER

MATERIAL NUMBER
101714710E

SHEET
2/2

MASCHINENFABRIK REINHAUSEN GMBH COPYRIGHT RESERVED
 THE REPRODUCTION, DISTRIBUTION AND UTILIZATION OF THIS DOCUMENT AS WELL AS THE COMMUNICATION OF ITS CONTENTS TO OTHERS WITHOUT EXPRESS AUTHORIZATION IS PROHIBITED. OFFENDERS WILL BE HELD LIABLE FOR THE PAYMENT OF DAMAGES. ALL RIGHTS RESERVED IN THE EVENT OF THE GRANT OF A PATENT, UTILITY MODEL OR DESIGN.

DATE	NAME	DOCUMENT NO.
26.07.2022	BUTERUS	SED 8943792.001.00
27.07.2022	WREDE	CHANGE NO.
27.07.2022	KLEYN	1116192
DFTR.	SCALE	1:10
CHKD.		
STAND.		

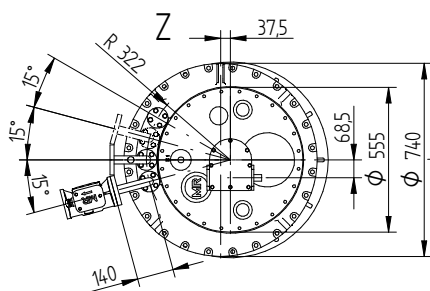
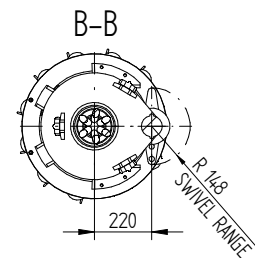
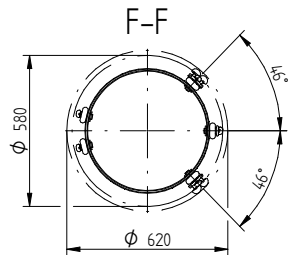
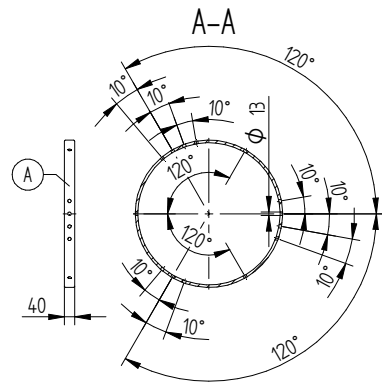
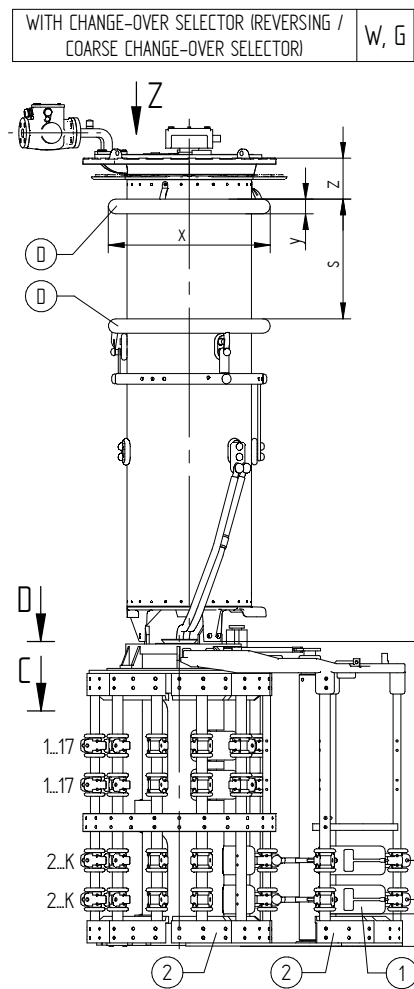
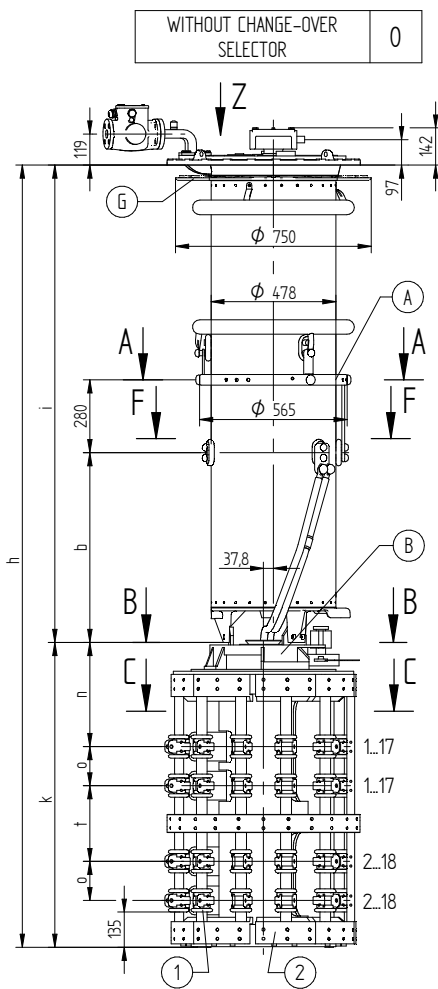

D-D REVERSING CHANGE-OVER SELECTOR (1W)

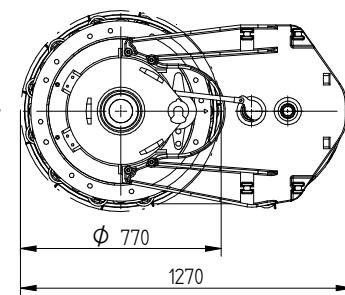

D-D COARSE CHANGE-OVER SELECTOR (1G)

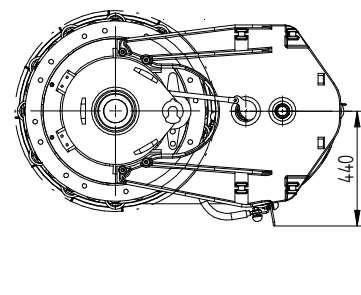

FOR THE TYPE OF OLTC-HEAD REFER TO THE ORDER-SPECIFIC DRAWING OF THE OLTC-HEAD AND DRIVE SHAFTS

- (M) - DRIVE SIDE OF SELECTOR
- (A) - ON-LOAD TAP-CHANGER CURRENT TAKE-OFF TERMINAL
- (B) - IS CONNECTED TO POTENTIAL OF (A)
- (D) - SHIELDING RINGS FOR UM OF 170 kV OR GREATER
- (G) - SUPPORTING FLANGE FOR THE BELL-TYPE TANK INSTALLATION IS OPTIONAL
- (1) - BOTTOM-MOST LIVE PARTS; THESE ARE CONNECTED TO THE POTENTIAL OF THE ASSOCIATED AND/OR WIRED CONNECTION CONTACT
- (2) - SELECTOR BASE IS MADE OF INSULATING MATERIAL

- THE DETAILED CONNECTION DIAGRAM IS BINDING FOR THE DESIGNATION OF THE CONNECTION CONTACTS AND PHASES

- C-C: REFER TO 10016570

- D-D: TYPE WITH CONNECTING LEAD 3W/3G REFER TO 10017264

DIMENSION IN mm EXCEPT AS NOTED



ON-LOAD TAP-CHANGER VACUTAP® VR®
 VRL I 1601 - 72,5 ... 420 kV - RE
 DIMENSION DRAWING

SERIAL NUMBER

MATERIAL NUMBER 101714720E SHEET 1/2

MASCHINENFABRIK REINHAUSEN GMBH COPYRIGHT RESERVED
 THE REPRODUCTION, DISTRIBUTION AND UTILIZATION OF THIS DOCUMENT AS WELL AS THE COMMUNICATION OF ITS CONTENTS TO OTHERS WITHOUT EXPRESS AUTHORIZATION IS
 PROHIBITED. OFFENDERS WILL BE HELD LIABLE FOR THE PAYMENT OF DAMAGES. ALL RIGHTS RESERVED IN THE EVENT OF THE GRANT OF A PATENT, UTILITY MODEL OR DESIGN.

DATE	NAME	DOCUMENT NO.
DFTR. 26.07.2022	BUTERUS	SED 8943792.001.00
CHKD. 27.07.2022	WREDE	CHANGE NO.
STAND 27.07.2022	KLEYN	1116192
		SCALE
		1:10

SELECTOR SIZE		RE						
Um [kV]		72,5	123	170	245	300	362	420
DIMENSIONS [mm]	h	2640	2770	2900	3000	3152	3255	3374
	i	1471	1601	1731	1831	1983	2086	2205
	b	728						
	s	-	-	302	402	554	573	692
	z	-	-	191	191	191	228	228
	x	-	-	∅ 620	∅ 620	∅ 620	∅ 695	∅ 695
	y	-	-	∅ 56	∅ 56	∅ 56	∅ 100	∅ 100
	k	1169						
	n	399						
	o	150						
	t	290						
	r	150						
	q	839						
OIL VOLUME [dm³]		205	225	245	265	285	305	325
DISPLACEMENT [dm³]		348	378	408	428	458	498	518
MAX. WEIGHT [kg]		541	547	559	563	569	576	581

DIMENSION
 IN mm
 EXCEPT AS
 NOTED



ON-LOAD TAP-CHANGER VACUTAP® VR®
 VRL I 1601 - 72,5 ... 420 kV - RE
 DIMENSION DRAWING

SERIAL NUMBER

MATERIAL NUMBER	SHEET
101714720E	2/2

DATE	NAME	DOCUMENT NO.
26.07.2022	BUTERUS	SED 8941115 001 00
27.07.2022	WREDE	CHANGE NO.
27.07.2022	KLEYN	1116192
		SCALE
		1:10

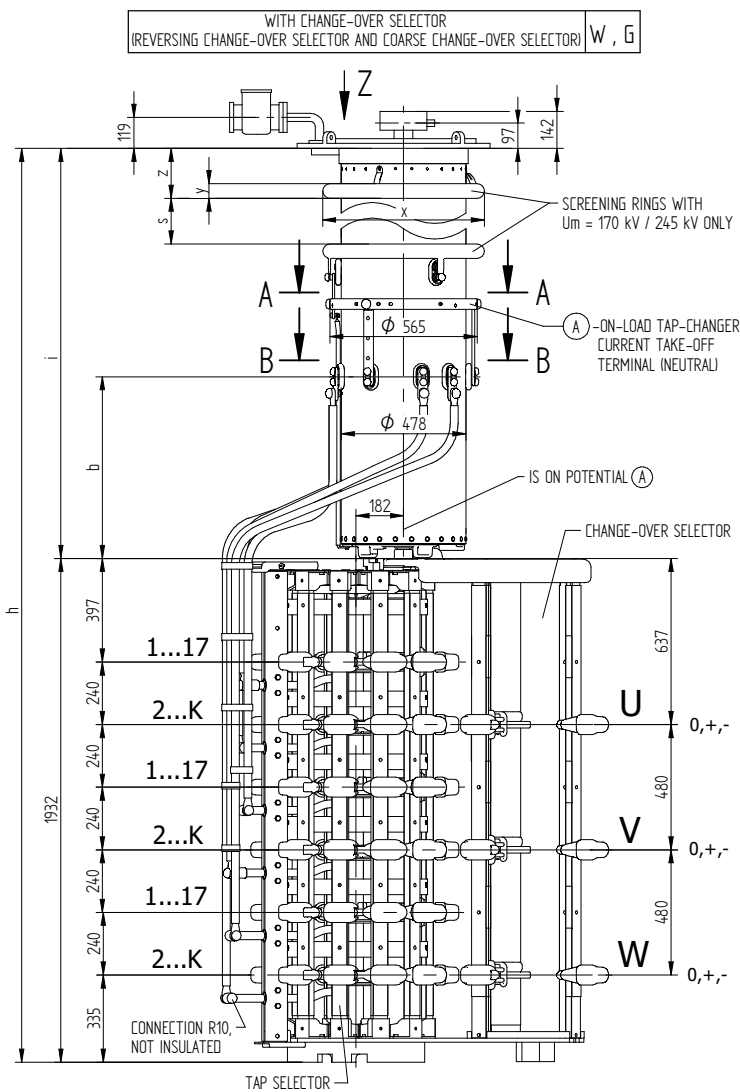

ARRANGEMENT OF CHANGE-OVER SELECTOR CONTACTS (PLAN VIEW)

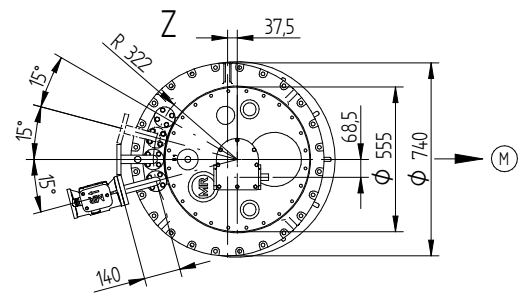
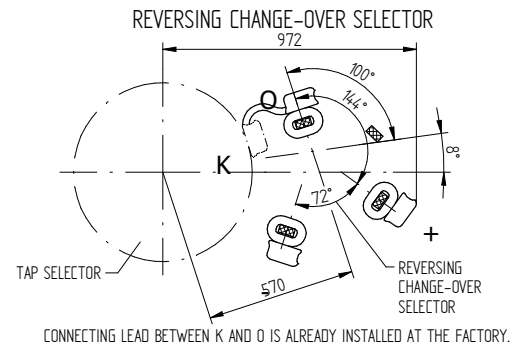
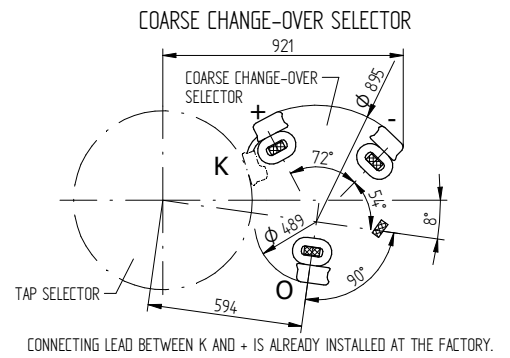

ARRANGEMENT OF TAP SELECTOR CONTACTS (PLAN VIEW)

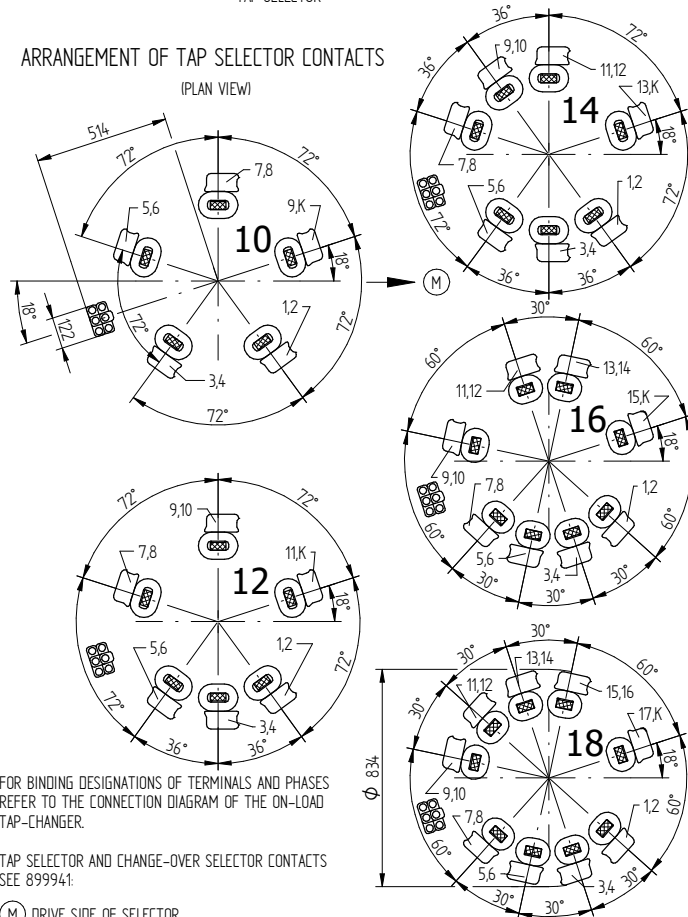

TAP SELECTOR AND CHANGE-OVER SELECTOR CONTACTS SEE 899941

(M) DRIVE SIDE OF SELECTOR

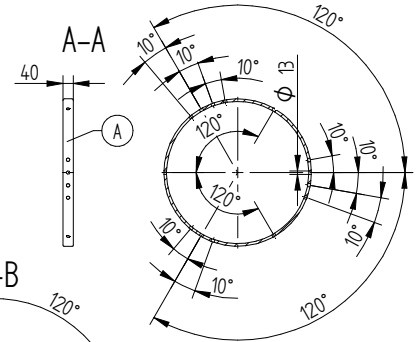

SELECTOR SIZE		E			
Um [kV]		72,5	123	170	245
DIMENSIONS [MM]	h	3372	3502	3632	3732
	i	1440	1570	1700	1800
	b	697			
	s	-	-	302	402
	z	-	-	191	191
	x	-	-	φ 620	φ 620
	y	-	-	φ 56	φ 56
OIL VOLUME [DM ³]		210	230	250	270
DISPLACEMENT [DM ³]		400	420	440	460
MAX. WEIGHT [KG]		807			

DIMENSION IN mm EXCEPT AS NOTED



ON-LOAD TAP-CHANGER VACUTAP® VR®
VRL III 1600 - 72,5 ... 245 kV - E
DIMENSION DRAWING

SERIAL NUMBER

MATERIAL NUMBER 101714700E SHEET 1/1

© MASCHINENFABRIK REINHAUSEN GMBH 2020
 THE REPRODUCTION, DISTRIBUTION AND UTILIZATION OF THIS DOCUMENT AS WELL AS THE COMMUNICATION OF ITS CONTENTS TO OTHERS WITHOUT EXPRESS AUTHORIZATION IS PROHIBITED. OFFENDERS WILL BE HELD LIABLE FOR THE PAYMENT OF DAMAGES. ALL RIGHTS RESERVED IN THE EVENT OF THE GRANT OF A PATENT, UTILITY MODEL OR DESIGN.

WITHOUT CHANGE-OVER SELECTOR 0

WITH CHANGE-OVER SELECTOR (REVERSING / COARSE CHANGE-OVER SELECTOR) W, G

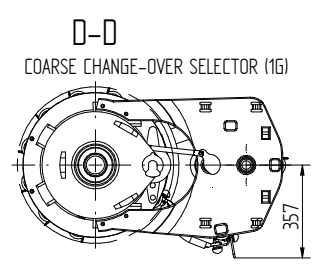
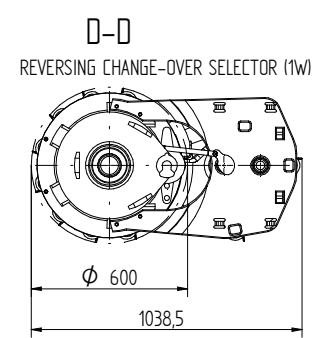
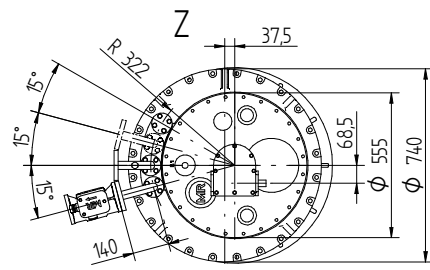
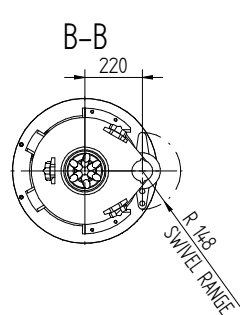
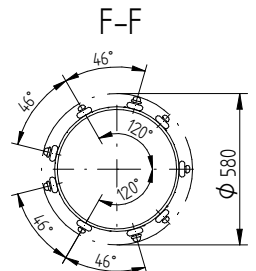
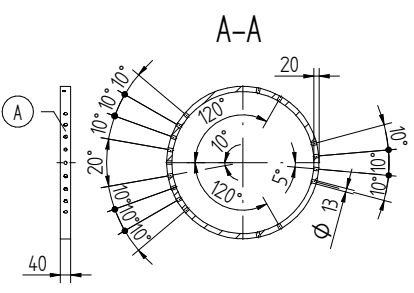
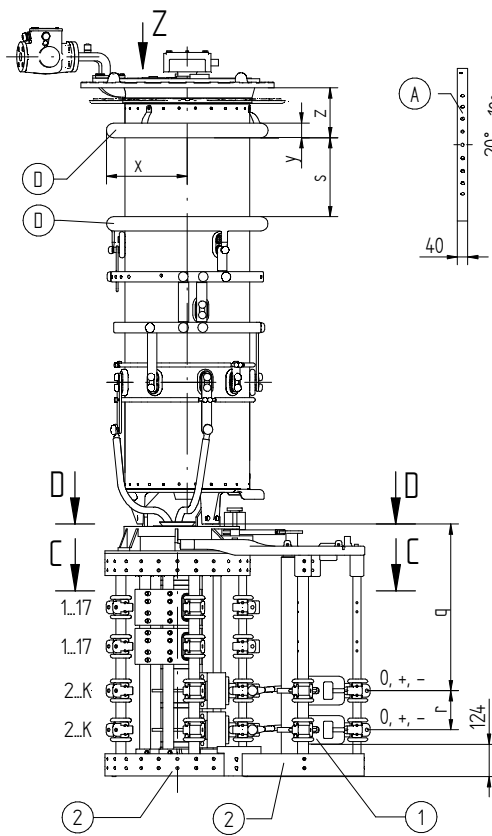
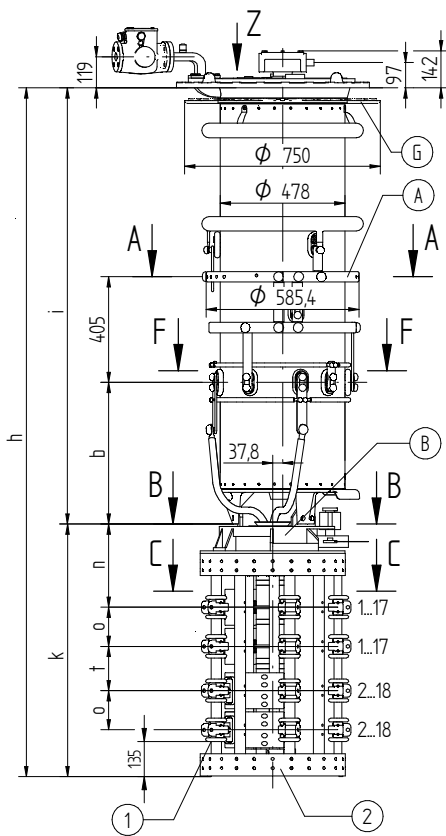

FOR THE TYPE OF THE OLTC-HEAD REFER TO THE ORDER-SPECIFIC DRAWING OF THE OLTC-HEAD AND DRIVE SHAFTS

- (M) - DRIVE SIDE OF SELECTOR
- (A) - ON-LOAD TAP-CHANGER CURRENT TAKE-OFF TERMINAL
- (B) - IS CONNECTED TO POTENTIAL OF (A)
- (D) - SHIELDING RINGS FOR UM OF 170 KV OR GREATER
- (G) - SUPPORTING FLANGE FOR THE BELL-TYPE TANK INSTALLATION IS OPTIONAL
- (1) - BOTTOM-MOST LIVE PARTS; THESE ARE CONNECTED TO THE POTENTIAL OF THE ASSOCIATED AND/OR WIRED CONNECTION CONTACT
- (2) - SELECTOR BASE IS MADE OF INSULATING MATERIAL

- THE DETAILED CONNECTION DIAGRAM IS BINDING FOR THE DESIGNATION OF THE CONNECTION CONTACTS AND PHASES
- C-C: REFER TO 10009030
- D-D: TYPE WITH CONNECTING LEAD 3W/3G REFER TO 10010019
- CONNECTING OF PARALLEL SELECTOR PLANES REFER TO 10009916

DATE	05.11.2021	DOCUMENT NO.	SED 8367958 001 01
DFTR.	08.11.2021	NAME	BUTERUS
CHKD.	09.11.2021	WREDE	KLEYN
STAND.		CHANGE NO.	1109989
		SCALE	1:10

DIMENSION IN mm EXCEPT AS NOTED



ON-LOAD TAP-CHANGER VACUTAP® VR®
 VRL I 1801/2001/2401 - 72,5...420 - RC/RD/RDE
 DIMENSION DRAWING

SERIAL NUMBER	
MATERIAL NUMBER	SHEET
101624770E	1/2

© MASCHINENFABRIK REINHAUSEN GMBH 2020
 THE REPRODUCTION, DISTRIBUTION AND UTILIZATION OF THIS DOCUMENT AS WELL AS THE COMMUNICATION OF ITS CONTENTS TO OTHERS WITHOUT EXPRESS AUTHORIZATION IS PROHIBITED. OFFENDERS WILL BE HELD LIABLE FOR THE PAYMENT OF DAMAGES. ALL RIGHTS RESERVED IN THE EVENT OF THE GRANT OF A PATENT, UTILITY MODEL OR DESIGN.

VACUTAP® VRL | 1801 / 2001

SELECTOR SIZE		RC						
Um [kV]		72,5	123	170	245	300	362	420
DIMENSIONS [mm]	h	2381	2511	2641	2741	2893	2996	3115
	b	543	543	543	543	543	543	543
	i	1412	1542	1672	1772	1924	2027	2146
	s	-	-	302	402	554	573	692
	z	-	-	191	191	191	228	228
	x	-	-	∅ 620	∅ 620	∅ 620	∅ 695	∅ 695
	y	-	-	∅ 56	∅ 56	∅ 56	∅ 100	∅ 100
	k	969						
	n	319						
	o	150						
	t	170						
	r	150						
q	639							
OIL VOLUME [dm³]		185	210	230	250	275	300	320
DISPLACEMENT [dm³]		300	330	360	380	415	450	470
MAX. WEIGHT [kg]		537	545	557	560	568	575	579

VACUTAP® VRL | 1801 / 2001

SELECTOR SIZE		RD / RDE						
Um [kV]		72,5	123	170	245	300	362	420
DIMENSIONS [mm]	h	2461	2591	2721	2821	2973	3076	3195
	b	543	543	543	543	543	543	543
	i	1412	1542	1672	1772	1924	2027	2146
	s	-	-	302	402	554	573	692
	z	-	-	191	191	191	228	228
	x	-	-	∅ 620	∅ 620	∅ 620	∅ 695	∅ 695
	y	-	-	∅ 56	∅ 56	∅ 56	∅ 100	∅ 100
	k	1049						
	n	359						
	o	150						
	t	210						
	r	150						
q	719							
OIL VOLUME [dm³]		185	210	230	250	275	300	320
DISPLACEMENT [dm³]		302	332	362	382	417	452	472
MAX. WEIGHT [kg]		542	550	562	565	573	580	584

DATE	NAME	DOCUMENT NO.
05.11.2021	BUTERUS	SED 8367958 001 01
08.11.2021	WREDE	CHANGE NO.
09.11.2021	KLEYN	1109989
DFTR.	SCALE	1:10
CHKD.		
STAND.		

DIMENSION
IN mm
EXCEPT AS
NOTED



ON-LOAD TAP-CHANGER VACUTAP® VR®
 VRL | 1801/2001/2401 - 72,5...420 - RC/RD/RDE
 DIMENSION DRAWING

SERIAL NUMBER

MATERIAL NUMBER	SHEET
101624770E	2/2

© MASCHINENFABRIK REINHAUSEN GMBH 2020
 THE REPRODUCTION, DISTRIBUTION AND UTILIZATION OF THIS DOCUMENT AS WELL AS THE COMMUNICATION OF ITS CONTENTS TO OTHERS WITHOUT EXPRESS AUTHORIZATION IS PROHIBITED. OFFENDERS WILL BE HELD LIABLE FOR THE PAYMENT OF DAMAGES. ALL RIGHTS RESERVED IN THE EVENT OF THE GRANT OF A PATENT, UTILITY MODEL OR DESIGN.

DATE	05.11.2021	DOCUMENT NO.	SED 8367960 001 00
DFTR.	08.11.2021	NAME	BUTERUS
CHKD.	09.11.2021	WREDE	KLEYN
STAND.		CHANGE NO.	1109989
		SCALE	1:10

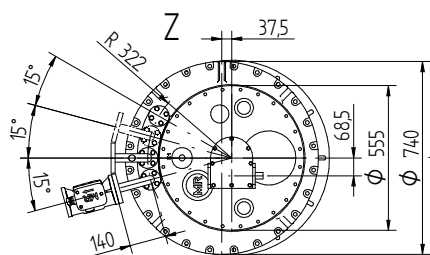
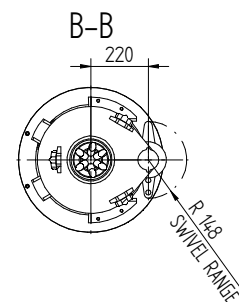
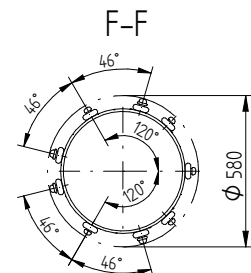
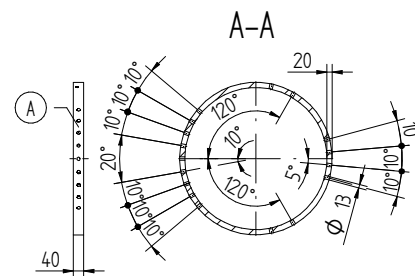
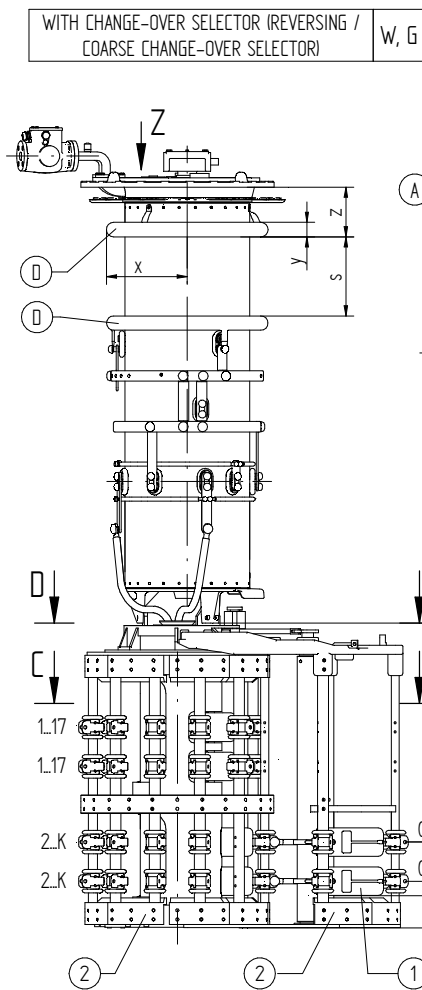
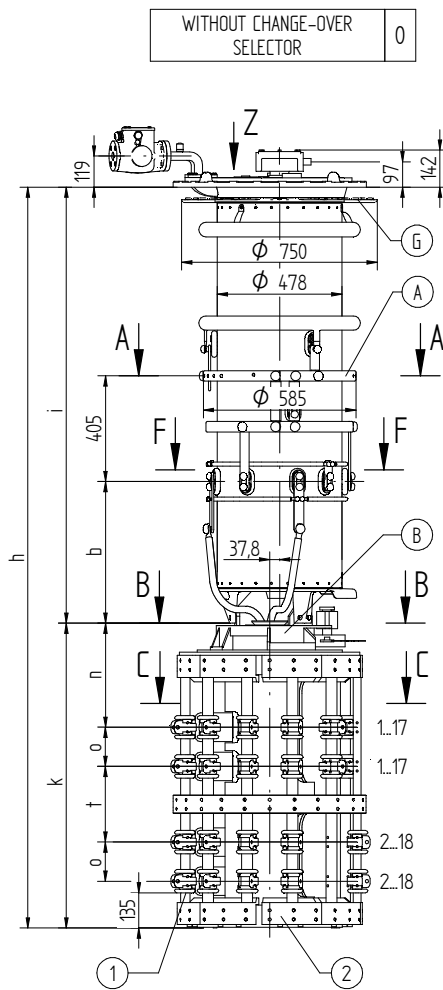

D-D REVERSING CHANGE-OVER SELECTOR (1W)

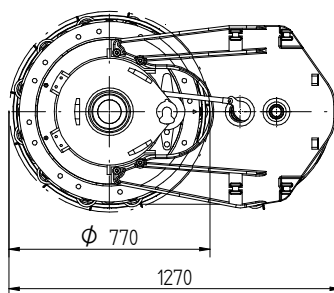

D-D COARSE CHANGE-OVER SELECTOR (1G)

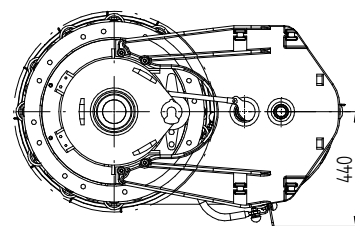

FOR THE TYPE OF THE OLTC-HEAD REFER TO THE ORDER-SPECIFIC DRAWING OF THE OLTC-HEAD AND DRIVE SHAFTS

- (M) - DRIVE SIDE OF SELECTOR
- (A) - ON-LOAD TAP-CHANGER CURRENT TAKE-OFF TERMINAL
- (B) - IS CONNECTED TO POTENTIAL OF (A)
- (D) - SHIELDING RINGS FOR UM OF 170 kV OR GREATER
- (G) - SUPPORTING FLANGE FOR THE BELL-TYPE TANK INSTALLATION IS OPTIONAL
- (1) - BOTTOM-MOST LIVE PARTS; THESE ARE CONNECTED TO THE POTENTIAL OF THE ASSOCIATED AND/OR WIRED CONNECTION CONTACT
- (2) - SELECTOR BASE IS MADE OF INSULATING MATERIAL

- THE DETAILED CONNECTION DIAGRAM IS BINDING FOR THE DESIGNATION OF THE CONNECTION CONTACTS AND PHASES
- C-C: REFER TO 10016570
- D-D: TYPE WITH CONNECTING LEAD 3W/3G REFER TO 10017264
- CONNECTING OF PARALLEL SELECTOR PLANES REFER TO 10009916

DIMENSION IN mm EXCEPT AS NOTED



ON-LOAD TAP-CHANGER VACUTAP® VR®
 VRL I 1801/2001/2401 - 72,5...420 - RE
 DIMENSION DRAWING

SERIAL NUMBER

MATERIAL NUMBER 101624780E SHEET 1/2

© MASCHINENFABRIK REINHAUSEN GMBH 2020
 THE REPRODUCTION, DISTRIBUTION AND UTILIZATION OF THIS DOCUMENT AS WELL AS THE COMMUNICATION OF ITS CONTENTS TO OTHERS WITHOUT EXPRESS AUTHORIZATION IS PROHIBITED. OFFENDERS WILL BE HELD LIABLE FOR THE PAYMENT OF DAMAGES. ALL RIGHTS RESERVED IN THE EVENT OF THE GRANT OF A PATENT, UTILITY MODEL OR DESIGN.

VACUTAP® VRL | 1801 / 2001

SELECTOR SIZE		RE						
Um [kV]		72,5	123	170	245	300	362	420
DIMENSIONS [mm]	h	2582	2712	2842	2942	3094	3197	3316
	b	543	543	543	543	543	543	543
	i	1412	1542	1672	1772	1924	2027	2146
	s	-	-	302	402	554	573	692
	z	-	-	191	191	191	228	228
	x	-	-	∅ 620	∅ 620	∅ 620	∅ 695	∅ 695
	y	-	-	∅ 56	∅ 56	∅ 56	∅ 100	∅ 100
	k	1170						
	n	400						
	o	150						
	t	290						
	r	150						
	q	840						
OIL VOLUME [dm³]		185	210	230	250	275	300	320
DISPLACEMENT [dm³]		337	367	397	417	452	487	507
MAX. WEIGHT [kg]		630	638	625	653	661	668	672

DATE	NAME	DOCUMENT NO.
05.11.2021	BUTERUS	SED 8367960 001 00
08.11.2021	WREDE	CHANGE NO.
09.11.2021	KLEYN	1109989
DFTR.	SCALE	1:10
CHKD.		
STAND		

DIMENSION
IN mm
EXCEPT AS
NOTED



ON-LOAD TAP-CHANGER VACUTAP® VR®
 VRL | 1801/2001/2401 - 72,5...420 - RE
 DIMENSION DRAWING

SERIAL NUMBER

MATERIAL NUMBER	SHEET
101624780E	2/2

© MASCHINENFABRIK REINHAUSEN GMBH 2020
 THE REPRODUCTION, DISTRIBUTION AND UTILIZATION OF THIS DOCUMENT AS WELL AS THE COMMUNICATION OF ITS CONTENTS TO OTHERS WITHOUT EXPRESS AUTHORIZATION IS PROHIBITED. OFFENDERS WILL BE HELD LIABLE FOR THE PAYMENT OF DAMAGES. ALL RIGHTS RESERVED IN THE EVENT OF THE GRANT OF A PATENT, UTILITY MODEL OR DESIGN.

WITHOUT CHANGE-OVER SELECTOR 0

WITH CHANGE-OVER SELECTOR (REVERSING / COARSE CHANGE-OVER SELECTOR) W, G

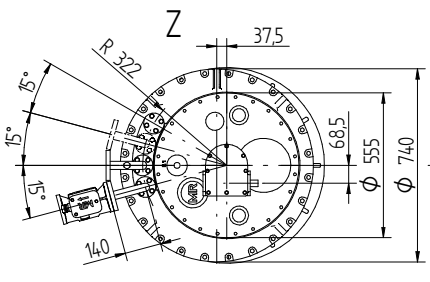
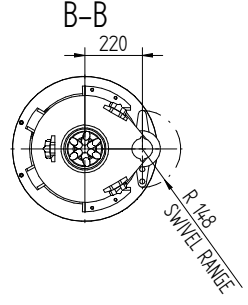
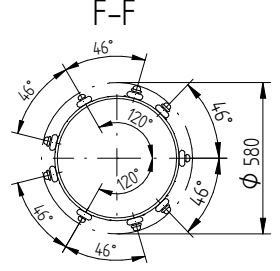
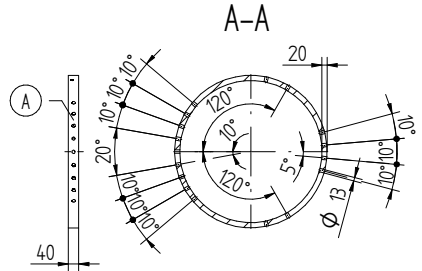
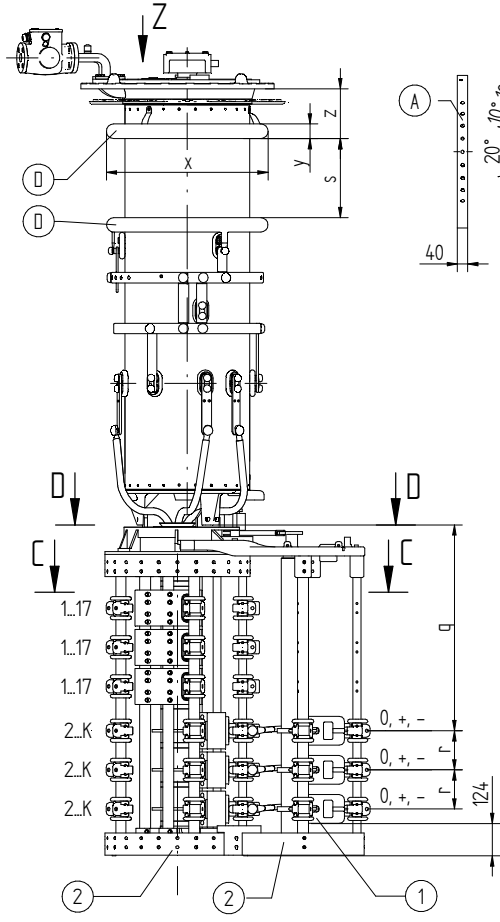
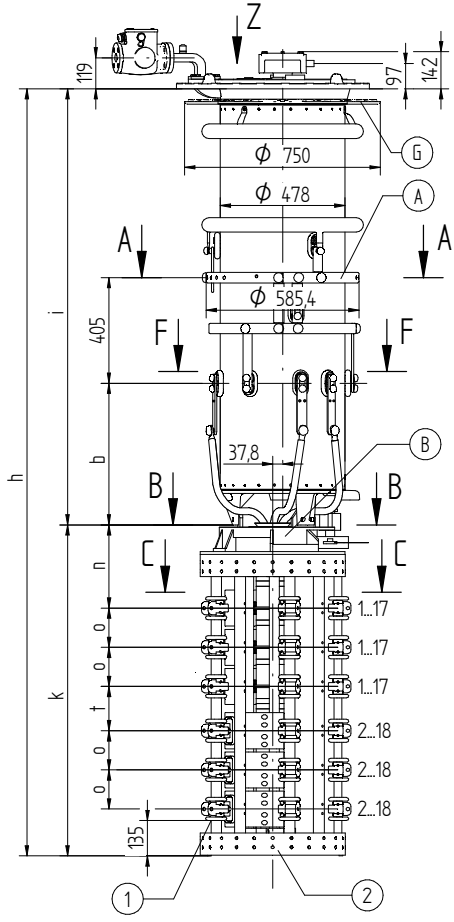

D-D REVERSING CHANGE-OVER SELECTOR (1W)

D-D COARSE CHANGE-OVER SELECTOR (1G)

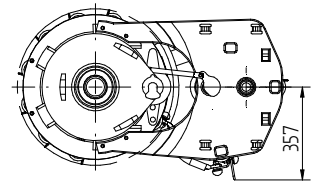
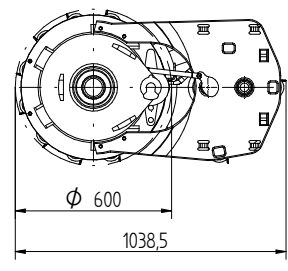

FOR THE TYPE OF THE OLTC-HEAD REFER TO THE ORDER-SPECIFIC DRAWING OF THE OLTC-HEAD AND DRIVE SHAFTS

- (M) - DRIVE SIDE OF SELECTOR
- (A) - ON-LOAD TAP-CHANGER CURRENT TAKE-OFF TERMINAL
- (B) - IS CONNECTED TO POTENTIAL OF (A)
- (D) - SHIELDING RINGS FOR UM OF 170 kV OR GREATER
- (G) - SUPPORTING FLANGE FOR THE BELL-TYPE TANK INSTALLATION IS OPTIONAL
- (1) - BOTTOM-MOST LIVE PARTS; THESE ARE CONNECTED TO THE POTENTIAL OF THE ASSOCIATED AND/OR WIRED CONNECTION CONTACT
- (2) - SELECTOR BASE IS MADE OF INSULATING MATERIAL

- THE DETAILED CONNECTION DIAGRAM IS BINDING FOR THE DESIGNATION OF THE CONNECTION CONTACTS AND PHASES
- C-C: REFER TO 10009030
- D-D: TYPE WITH CONNECTING LEAD 3W/3G REFER TO 10010019
- CONNECTING OF PARALLEL SELECTOR PLANES REFER TO 10009916

DATE	29.11.2021	NAME	BUTERUS	DOCUMENT NO.	SED 8367934_001 01
DFTR.	02.12.2021	WREDE	WANNINGER	CHANGE NO.	111654
CHKO.	02.12.2021	SCALE	1:10		

DIMENSION IN mm EXCEPT AS NOTED



ON-LOAD TAP-CHANGER VACUTAP® VR®
 VRL I 2601/3001/3201 - 72,5...420 - RC/RD/RDE
 DIMENSION DRAWING

SERIAL NUMBER	
MATERIAL NUMBER	SHEET
101624740E	1/2

© MASCHINENFABRIK REINHAUSEN GMBH 2020
 THE REPRODUCTION, DISTRIBUTION AND UTILIZATION OF THIS DOCUMENT AS WELL AS THE COMMUNICATION OF ITS CONTENTS TO OTHERS WITHOUT EXPRESS AUTHORIZATION IS PROHIBITED. OFFENDERS WILL BE HELD LIABLE FOR THE PAYMENT OF DAMAGES. ALL RIGHTS RESERVED IN THE EVENT OF THE GRANT OF A PATENT, UTILITY MODEL OR DESIGN.

VACUTAP® VRL | 2601 / 3001 / 3201

SELECTOR SIZE		RC						
Um [kV]		72,5	123	170	245	300	362	420
DIMENSIONS [mm]	h	2681	2811	2941	3041	3193	3296	3415
	b	543	543	543	543	543	543	543
	i	1412	1542	1672	1772	1924	2027	2146
	s	-	-	302	402	554	573	692
	z	-	-	191	191	191	228	228
	x	-	-	∅ 620	∅ 620	∅ 620	∅ 695	∅ 695
	y	-	-	∅ 56	∅ 56	∅ 56	∅ 100	∅ 100
	k	1269						
	n	319						
	o	150						
	t	170						
r	150							
q	789							
OIL VOLUME [dm³]		185	210	230	250	265	300	320
DISPLACEMENT [dm³]		312	342	372	392	517	462	482
MAX. WEIGHT [kg]		582	590	602	605	613	620	624

VACUTAP® VRL | 2601 / 3001 / 3201

SELECTOR SIZE		RD / RDE						
Um [kV]		72,5	123	170	245	300	362	420
DIMENSIONS [mm]	h	2761	2891	3021	3121	3273	3376	3495
	b	543	543	543	543	543	543	543
	i	1412	1542	1672	1772	1924	2027	2146
	s	-	-	302	402	554	573	692
	z	-	-	191	191	191	228	228
	x	-	-	∅ 620	∅ 620	∅ 620	∅ 695	∅ 695
	y	-	-	∅ 56	∅ 56	∅ 56	∅ 100	∅ 100
	k	1349						
	n	359						
	o	150						
	t	210						
r	150							
q	869							
OIL VOLUME [dm³]		185	210	230	250	275	300	320
DISPLACEMENT [dm³]		313	343	373	393	428	463	483
MAX. WEIGHT [kg]		588	596	608	611	619	626	630

DATE	NAME	DOCUMENT NO.
29.11.2021	BUTERUS	SED 8367934_001 01
02.12.2021	WREDE	CHANGE NO.
02.12.2021	WANNINGER	111654
DFTR.	SCALE	1:10
CHKD.		
STAND.		

DIMENSION
IN mm
EXCEPT AS
NOTED



ON-LOAD TAP-CHANGER VACUTAP® VR®
 VRL | 2601/3001/3201 - 72,5...420 - RC/RD/RDE
 DIMENSION DRAWING

SERIAL NUMBER

MATERIAL NUMBER	SHEET
101624740E	2/2

© MASCHINENFABRIK REINHAUSEN GMBH 2020
 THE REPRODUCTION, DISTRIBUTION AND UTILIZATION OF THIS DOCUMENT AS WELL AS THE COMMUNICATION OF ITS CONTENTS TO OTHERS WITHOUT EXPRESS AUTHORIZATION IS PROHIBITED. OFFENDERS WILL BE HELD LIABLE FOR THE PAYMENT OF DAMAGES. ALL RIGHTS RESERVED IN THE EVENT OF THE GRANT OF A PATENT, UTILITY MODEL OR DESIGN.

DATE	NAME	DOCUMENT NO.
29.11.2021	BUTERUS	SED 8367950 001 01
02.12.2021	WREDE	CHANGE NO.
02.12.2021	WANNINGER	111654
DFTR.	SCALE	1:10
CHKD.		
STAND.		

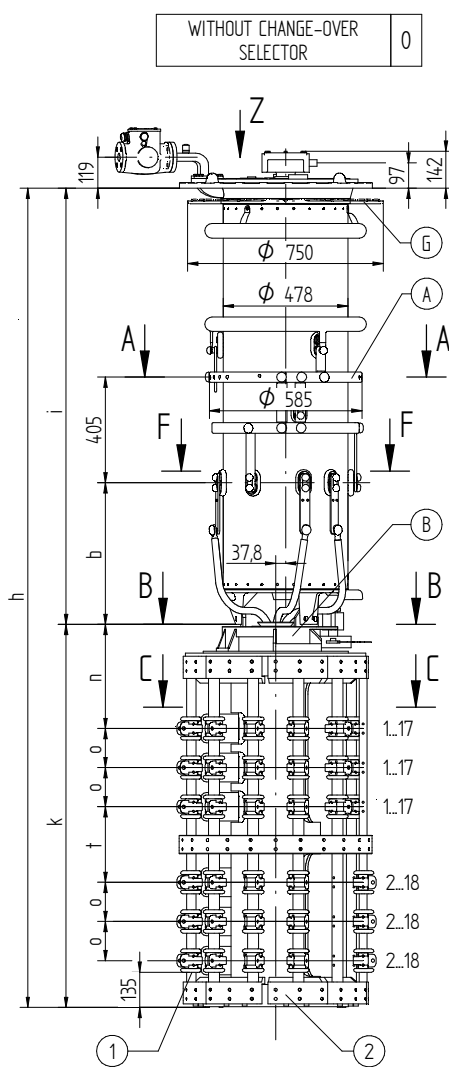

WITHOUT CHANGE-OVER SELECTOR 0

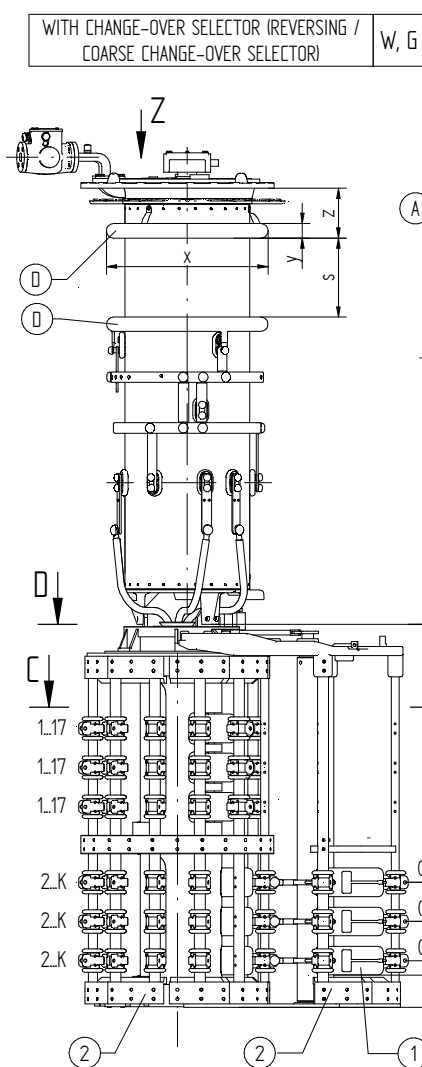

WITH CHANGE-OVER SELECTOR (REVERSING / COARSE CHANGE-OVER SELECTOR) W, G

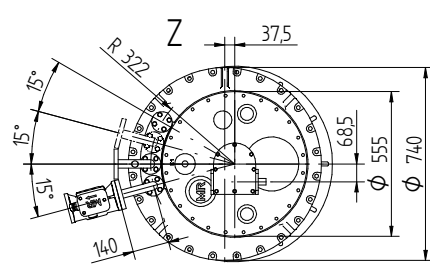
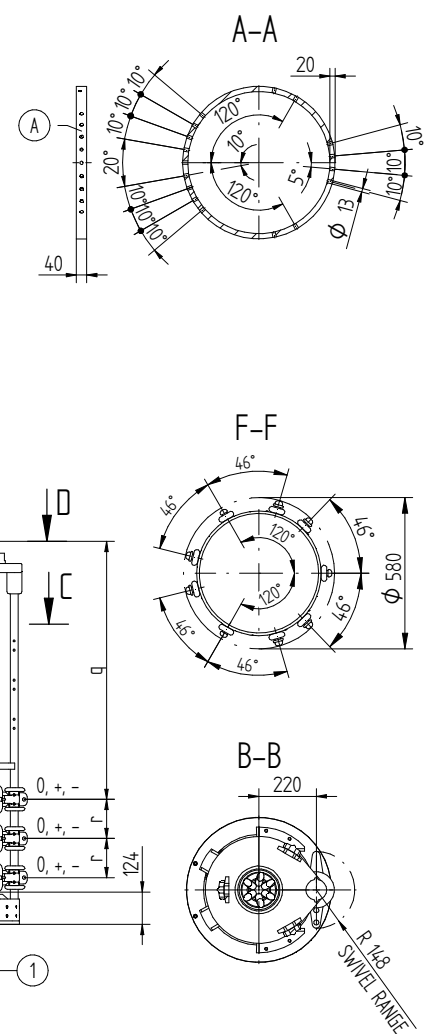

D-D REVERSING CHANGE-OVER SELECTOR (1W)

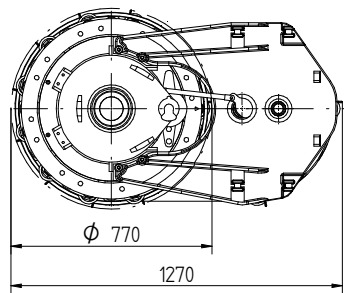

D-D COARSE CHANGE-OVER SELECTOR (1G)

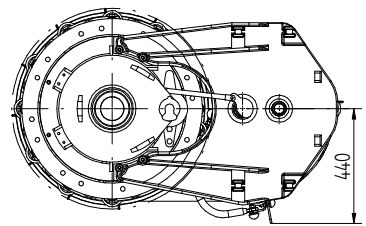

FOR THE TYPE OF THE OLTC-HEAD REFER TO THE ORDER-SPECIFIC DRAWING OF THE OLTC-HEAD AND DRIVE SHAFTS

- (M) - DRIVE SIDE OF SELECTOR
- (A) - ON-LOAD TAP-CHANGER CURRENT TAKE-OFF TERMINAL
- (B) - IS CONNECTED TO POTENTIAL OF (A)
- (D) - SHIELDING RINGS FOR UM OF 170 kV OR GREATER
- (G) - SUPPORTING FLANGE FOR THE BELL-TYPE TANK INSTALLATION IS OPTIONAL
- (1) - BOTTOM-MOST LIVE PARTS; THESE ARE CONNECTED TO THE POTENTIAL OF THE ASSOCIATED AND/OR WIRED CONNECTION CONTACT
- (2) - SELECTOR BASE IS MADE OF INSULATING MATERIAL

- THE DETAILED CONNECTION DIAGRAM IS BINDING FOR THE DESIGNATION OF THE CONNECTION CONTACTS AND PHASES
- C-C: REFER TO 10016570
- D-D: TYPE WITH CONNECTING LEAD 3W/3G REFER TO 10017264
- CONNECTING OF PARALLEL SELECTOR PLANES REFER TO 10009916

DIMENSION IN mm EXCEPT AS NOTED



ON-LOAD TAP-CHANGER VACUTAP® VR®
 VRL I 2601/3001/3201 - 72,5...420 - RE
 DIMENSION DRAWING

SERIAL NUMBER	
MATERIAL NUMBER	SHEET
101624750E	1/2

© MASCHINENFABRIK REINHAUSEN GMBH 2020
 THE REPRODUCTION, DISTRIBUTION AND UTILIZATION OF THIS DOCUMENT AS WELL AS THE COMMUNICATION OF ITS CONTENTS TO OTHERS WITHOUT EXPRESS AUTHORIZATION IS PROHIBITED. OFFENDERS WILL BE HELD LIABLE FOR THE PAYMENT OF DAMAGES. ALL RIGHTS RESERVED IN THE EVENT OF THE GRANT OF A PATENT, UTILITY MODEL OR DESIGN.

VACUTAP® VRL | 2601 / 3001 / 3201

SELECTOR SIZE		RE						
Um [kV]		72,5	123	170	245	300	362	420
DIMENSIONS [mm]	h	2882	3012	3142	3242	3394	3497	3616
	b	543	543	543	543	543	543	543
	i	1412	1542	1672	1772	1924	2027	2146
	s	-	-	302	402	554	573	692
	z	-	-	191	191	191	228	228
	x	-	-	∅ 620	∅ 620	∅ 620	∅ 695	∅ 695
	y	-	-	∅ 56	∅ 56	∅ 56	∅ 100	∅ 100
	k	1470						
	n	400						
	o	150						
	t	290						
	r	150						
	q	990						
OIL VOLUME [dm³]		185	210	230	250	275	300	320
DISPLACEMENT [dm³]		351	381	411	431	466	501	521
MAX. WEIGHT [kg]		696	704	716	719	727	734	738

DATE	NAME	DOCUMENT NO.
29.11.2021	BUTERUS	SED 8367950 001 01
02.12.2021	WREDE	CHANGE NO.
02.12.2021	WANNINGER	111654
DFTR.		SCALE
CHKD.		1:10
STAND.		

DIMENSION
IN mm
EXCEPT AS
NOTED



ON-LOAD TAP-CHANGER VACUTAP® VR®
 VRL | 2601/3001/3201 - 72,5...420 - RE
 DIMENSION DRAWING

SERIAL NUMBER

MATERIAL NUMBER	SHEET
101624750E	2/2

4.3 설치 도면

MASCHINENFABRIK REINHAUSEN GMBH COPYRIGHT RESERVED
 THE REPRODUCTION, DISTRIBUTION AND UTILIZATION OF THIS DOCUMENT AS WELL AS THE COMMUNICATION OF ITS CONTENTS TO OTHERS WITHOUT EXPRESS AUTHORIZATION IS PROHIBITED. OFFENDERS WILL BE HELD LIABLE FOR THE PAYMENT OF DAMAGES. ALL RIGHTS RESERVED IN THE EVENT OF THE GRANT OF A PATENT, UTILITY MODEL OR DESIGN.

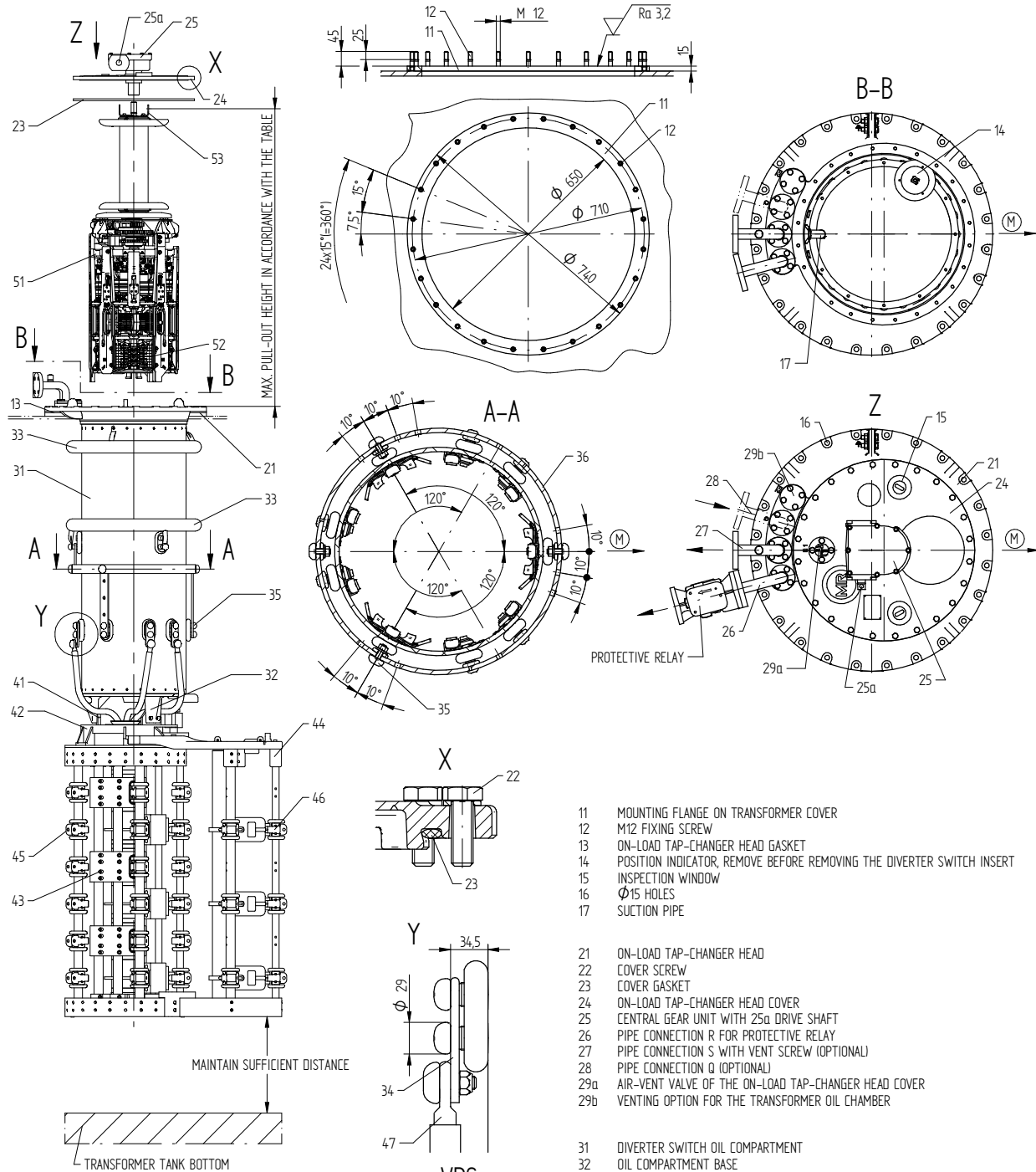

- 11 MOUNTING FLANGE ON TRANSFORMER COVER
- 12 M12 FIXING SCREW
- 13 ON-LOAD TAP-CHANGER HEAD GASKET
- 14 POSITION INDICATOR, REMOVE BEFORE REMOVING THE DIVERTER SWITCH INSERT
- 15 INSPECTION WINDOW
- 16 Ø15 HOLES
- 17 SUCTION PIPE

- 21 ON-LOAD TAP-CHANGER HEAD
- 22 COVER SCREW
- 23 COVER GASKET
- 24 ON-LOAD TAP-CHANGER HEAD COVER
- 25 CENTRAL GEAR UNIT WITH 25a DRIVE SHAFT
- 26 PIPE CONNECTION R FOR PROTECTIVE RELAY
- 27 PIPE CONNECTION S WITH VENT SCREW (OPTIONAL)
- 28 PIPE CONNECTION Q (OPTIONAL)
- 29a AIR-VENT VALVE OF THE ON-LOAD TAP-CHANGER HEAD COVER
- 29b VENTING OPTION FOR THE TRANSFORMER OIL CHAMBER

- 31 DIVERTER SWITCH OIL COMPARTMENT
- 32 OIL COMPARTMENT BASE
- 33 SHIELDING RINGS FOR UM OF 170 kV OR GREATER
- 34 OIL COMPARTMENT CONNECTION TERMINAL
- 35 CONNECTION CONTACT FOR ON-LOAD TAP-CHANGER TAKE-OFF LEAD
- 36 TAKE-OFF RING FOR ON-LOAD TAP-CHANGER TAKE-OFF LEAD

- 41 SELECTOR SUSPENSION
 - 42 SELECTOR GEAR
 - 43 FINE TAP SELECTOR
 - 44 CHANGE-OVER SELECTOR
 - 45 SELECTOR CONNECTION CONTACTS (SEE ASSOCIATED DIMENSIONAL DRAWING)
 - 46 CHANGE-OVER SELECTOR CONNECTION CONTACTS (SEE ASSOCIATED DIMENSIONAL DRAWING)
 - 47 SELECTOR CONNECTING LEAD
- } RC VARIANT DISPLAYED

- 51 DIVERTER SWITCH INSERT
- 52 TRANSITION RESISTANCES
- 53 EYEBOLT

(M) → SELECTOR DRIVE SIDE

Um [kV]	MAX. PULL-OUT HEIGHT [mm]		
	SELECTOR SIZE		
	VRS	VR M/X/H650	VR L/H1300 VRL I 1601
72,5	1200	1350	1500
123	1330	1480	1630
170	1460	1610	1760
245	1560	1710	1860
300	1712	1862	2012
362	1815	1965	2115
420	1934	2084	2234

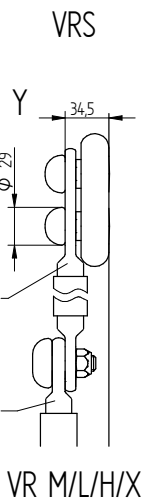

DATE	NAME	DOCUMENT NO.
26.07.2022	BUTERUS	SED 5127328 001 02
27.07.2022	WREDE	CHANGE NO.
27.07.2022	KLEYN	1116192
		SCALE
		1

DIMENSION IN mm EXCEPT AS NOTED



ON-LOAD TAP-CHANGER VACUTAP® VR®
INSTALLATION DRAWING VR S/M/L/H/X - RC/RD/RDE/RE/RF/RES
DIMENSION DRAWING

SERIAL NUMBER

MATERIAL NUMBER 100177201E SHEET 1/1

© MASCHINENFABRIK REINHAUSEN GMBH 2020
 THE REPRODUCTION, DISTRIBUTION AND UTILIZATION OF THIS DOCUMENT AS WELL AS THE COMMUNICATION OF ITS CONTENTS TO OTHERS WITHOUT EXPRESS AUTHORIZATION IS PROHIBITED. OFFENDERS WILL BE HELD LIABLE FOR THE PAYMENT OF DAMAGES. ALL RIGHTS RESERVED IN THE EVENT OF A PATENT, UTILITY MODEL OR DESIGN.

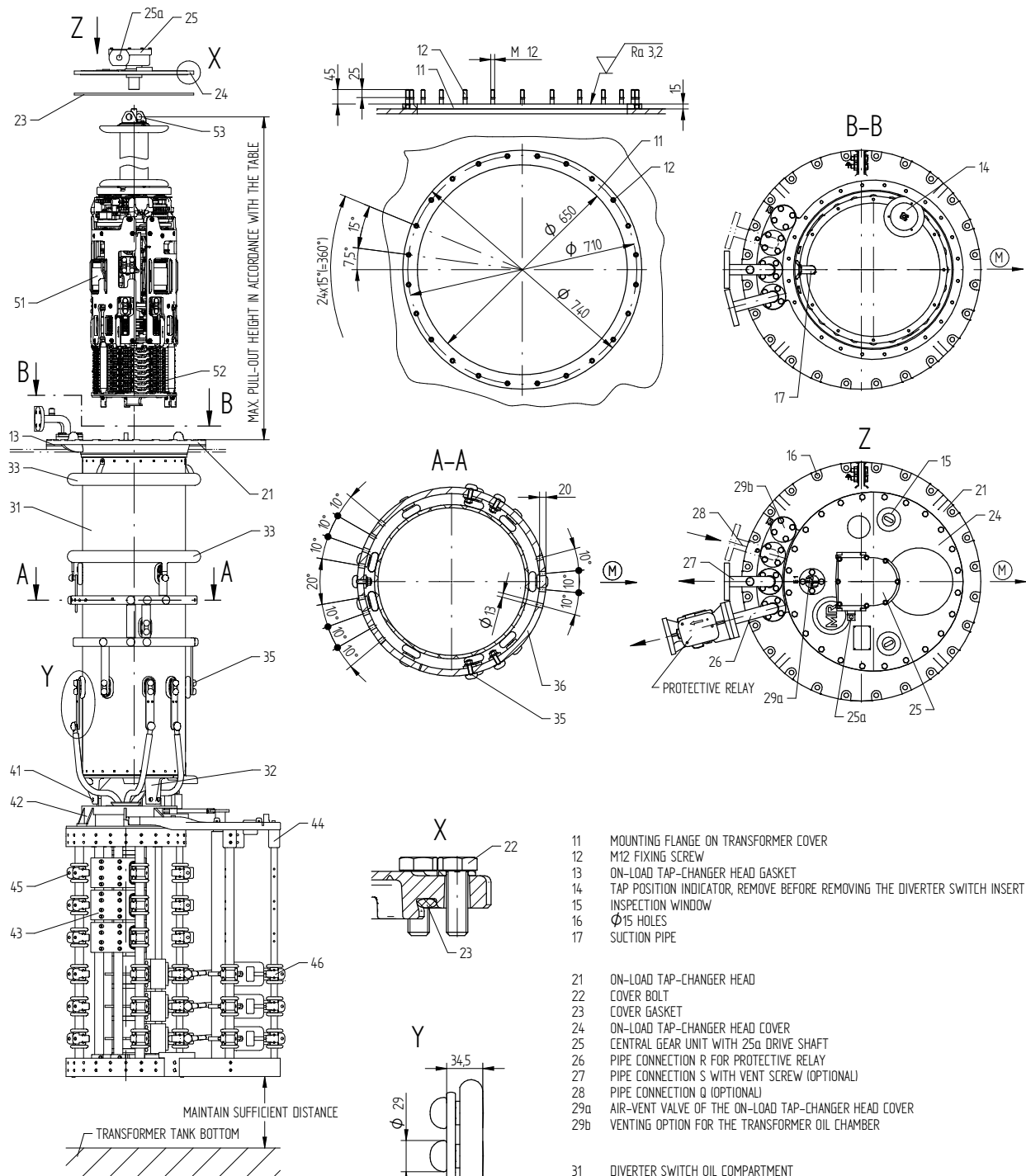

- 11 MOUNTING FLANGE ON TRANSFORMER COVER
- 12 M12 FIXING SCREW
- 13 ON-LOAD TAP-CHANGER HEAD GASKET
- 14 TAP POSITION INDICATOR, REMOVE BEFORE REMOVING THE DIVERTER SWITCH INSERT
- 15 INSPECTION WINDOW
- 16 Ø15 HOLES
- 17 SUCTION PIPE

- 21 ON-LOAD TAP-CHANGER HEAD
- 22 COVER BOLT
- 23 COVER GASKET
- 24 ON-LOAD TAP-CHANGER HEAD COVER
- 25 CENTRAL GEAR UNIT WITH 25a DRIVE SHAFT
- 26 PIPE CONNECTION R FOR PROTECTIVE RELAY
- 27 PIPE CONNECTION S WITH VENT SCREW (OPTIONAL)
- 28 PIPE CONNECTION Q (OPTIONAL)
- 29a AIR-VENT VALVE OF THE ON-LOAD TAP-CHANGER HEAD COVER
- 29b VENTING OPTION FOR THE TRANSFORMER OIL CHAMBER

- 31 DIVERTER SWITCH OIL COMPARTMENT
- 32 OIL COMPARTMENT BASE
- 33 SHIELDING RINGS FOR UM OF 170 kV OR GREATER
- 34 OIL COMPARTMENT CONNECTION TERMINAL
- 35 CONNECTION CONTACT FOR ON-LOAD TAP-CHANGER TAKE-OFF LEAD
- 36 TAKE-OFF RING FOR ON-LOAD TAP-CHANGER TAKE-OFF LEAD

- 41 SELECTOR SUSPENSION
- 42 SELECTOR GEAR
- 43 TAP SELECTOR
- 44 CHANGE-OVER SELECTOR
- 45 SELECTOR CONNECTION CONTACTS (SEE ASSOCIATED DIMENSION DRAWING)
- 46 CHANGE-OVER SELECTOR CONNECTION CONTACTS (SEE ASSOCIATED DIMENSION DRAWING)
- 47 SELECTOR CONNECTING LEAD

RC VARIANT DISPLAYED

(M) → SELECTOR DRIVE SIDE

DATE	08.12.2021	NAME	BUTERUS	DOCUMENT NO.	SED 8367971 001 02
DFTR.	08.12.2021	NAME	SCHMIDT	CHANGE NO.	111654
CHKD.	08.12.2021	NAME	WANNINGER	SCALE	1:10
STAND.	08.12.2021				

Um [kV]	MAX. PULL-OUT HEIGHT [mm]
72.5	1350
123	1480
170	1610
245	1710
300	1860
362	1970
420	2090

DIMENSION IN mm EXCEPT AS NOTED



ON-LOAD TAP-CHANGER VACUTAP® VR®
 VRL I 1801 ... 3201 - RC/RD/RDE/RE
 INSTALLATION DRAWING

SERIAL NUMBER	
MATERIAL NUMBER	SHEET
101624730E	1/1

4.4 부하시 탭 절환장치 헤드

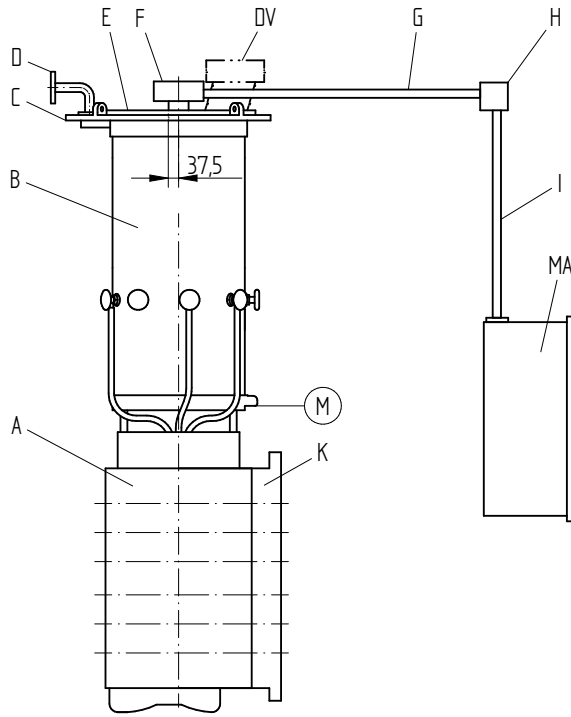

- A = selector
 - K = change-over selector
 - B = diverter switch oil compartment
 - C = on-load tap-changer head
 - D = pipe connections (R, S, Q, E2)
 - DV = pressure relief device
 - E = on-load tap-changer head cover
 - F = upper gear unit
 - G = drive shaft, horizontal
 - H = bevel gear
 - I = drive shaft, vertical
 - MA = motor-drive unit
 - (M) = drive side of selector
 - SR = inspection window on the right
 - SL = inspection window on the left
 - T = temperature sensor
- } represented
version
type M

Position of drive shaft of gear unit

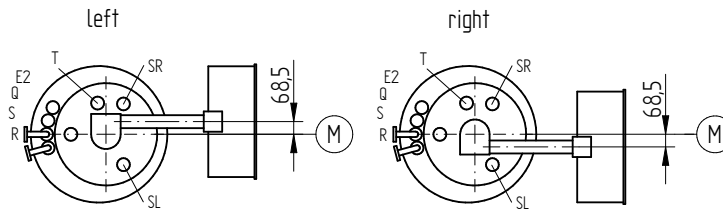

Head variants

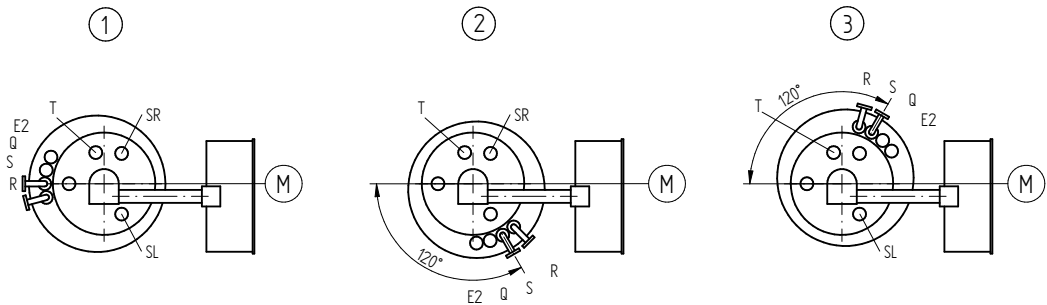

Swivel ranges

A considerable number of variants of the on-load tap-changer head are available for adapting the horizontal part of the drive shaft to the transformer tank.

The mounting position of the selector A and diverter switch oil compartment B is determined by the drive side of selector (M).

The on-load tap-changer head C together with its pipe connections D may be turned through 120 degrees clockwise or anti-clockwise. This results in the variants 1, 2 and 3.

The upper gear unit F can be turned continuously on its own axis. Table 720027: Lists the limitation of the swivel range for the particular head variant. The angle specifications refer to the center of rotation of the gear unit. Pay particular attention to the offset of the drive shaft.

DATE	11.07.2018	DOCUMENT NO.	SED 1063796 001 05
DATE	16.07.2018	NAME	BUTERUS
DATE	16.07.2018	NAME	WILHELM
DATE	16.07.2018	NAME	PRODASTSCHUK
CHG. NO.	1086956	SCALE	1

DIMENSION
IN mm
EXCEPT AS
NOTED



ON-LOAD TAP-CHANGER
OILTAP® MS, M, RM, R AND VACUTAP® VR®, VM®, VMS®
VARIANTS OF THE ON-LOAD TAP-CHANGER HEAD

SERIAL NUMBER

MATERIAL NUMBER
7200264E

SHEET
1/1

© MASCHINENFABRIK REINHAUSEN GMBH 2018
 THE REPRODUCTION, DISTRIBUTION AND UTILIZATION OF THIS DOCUMENT AS WELL AS THE COMMUNICATION OF ITS CONTENTS TO OTHERS WITHOUT EXPRESS AUTHORIZATION IS PROHIBITED. OFFENDERS WILL BE HELD LIABLE FOR THE PAYMENT OF DAMAGES. ALL RIGHTS RESERVED IN THE EVENT OF THE GRANT OF A PATENT, UTILITY MODEL OR DESIGN.

DFTR.	DATE	NAME	DOCUMENT NO.
CHKD.	11.07.2018	BUTERUS	SED 1661250 001 03
STANDJ.	16.07.2018	WILHELM	CHANGE NO. SCALE
	16.07.2018	PRODASTSCHUK	1086956 1:2,5

DIMENSION
 IN mm
 EXCEPT AS
 NOTED



ON-LOAD TAP-CHANGER
 OILTAP® M, MS, R, RM AND VACUTAP® VR®, VM®, VMS®
 WITH MOUNTING FLANGE FOR PRESSURE RELIEF DEVICE

SERIAL NUMBER

MATERIAL NUMBER
 8951689E

SHEET
 1/1

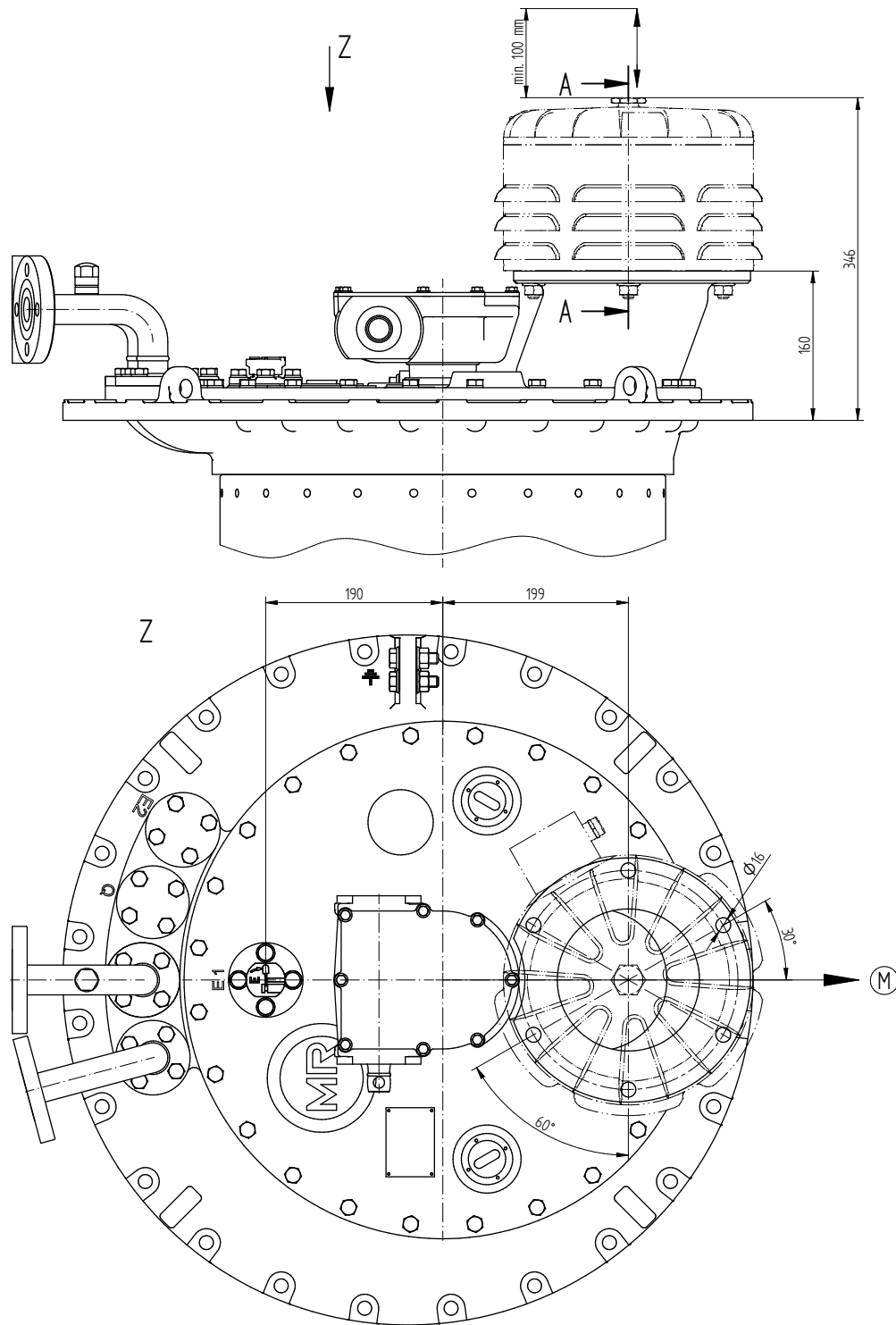

(M) DRIVE SIDE OF SELECTOR

A-A
 1:1

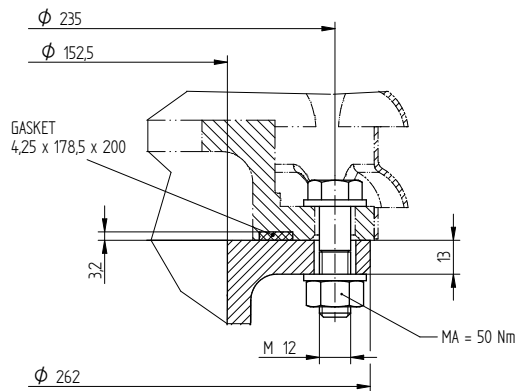

© MASCHINENFABRIK REINHAUSEN GMBH 2018
 THE REPRODUCTION, DISTRIBUTION AND UTILIZATION OF THIS DOCUMENT AS WELL AS THE COMMUNICATION OF ITS CONTENTS TO OTHERS WITHOUT EXPRESS AUTHORIZATION IS PROHIBITED. OFFENDERS WILL BE HELD LIABLE FOR THE PAYMENT OF DAMAGES. ALL RIGHTS RESERVED IN THE EVENT OF THE GRANT OF A PATENT, UTILITY MODEL OR DESIGN.

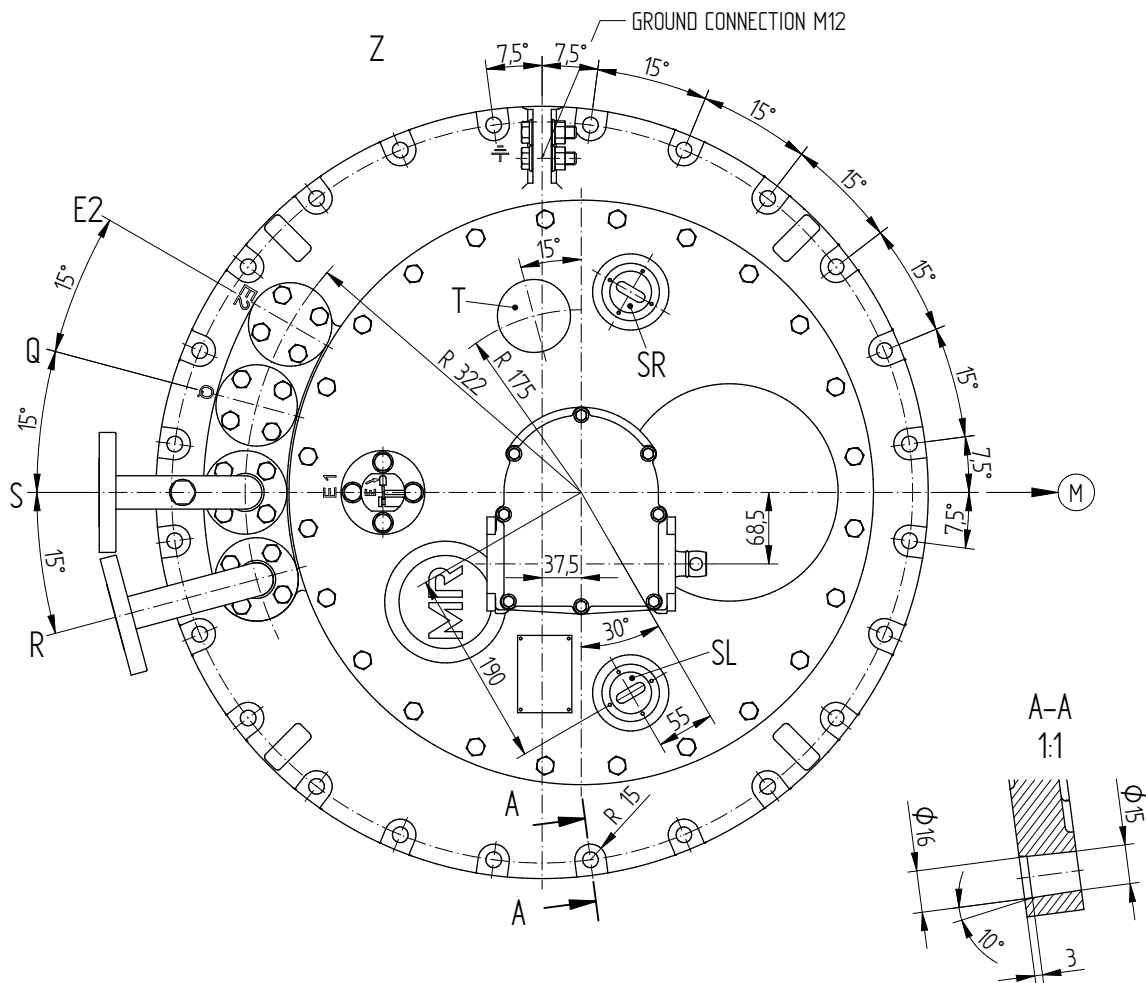
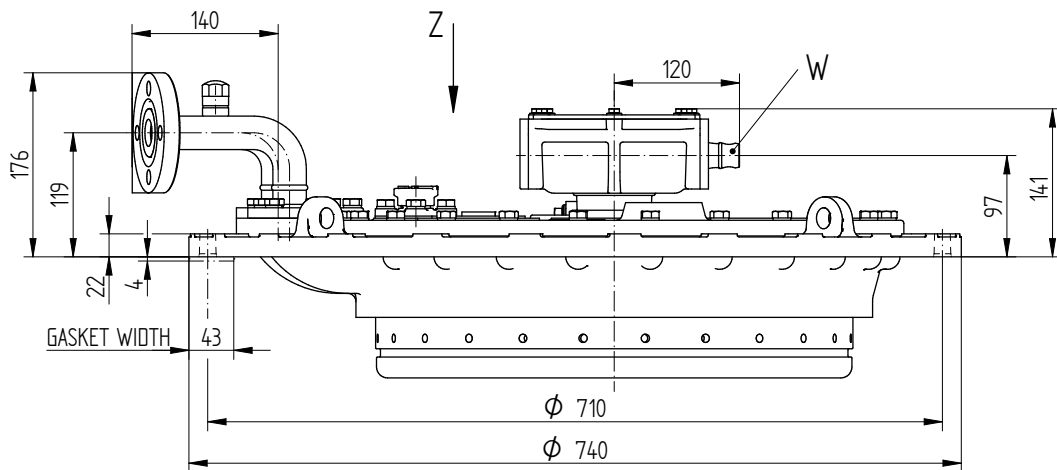

E1 = BLEEDING FACILITY FOR ON-LOAD TAP-CHANGER HEAD

E2 = BLEEDING FACILITY FOR SPACE UNDER THE HEAD OUTSIDE

THE TAP-CHANGER OIL COMPARTMENT (SAME PIPE CONNECTION AS R, S, Q OR BLEEDER SCREW CAN BE USED)

Q = CONNECTION FOR OIL RETURN PIPE OR TAP-CHANGE SUPERVISORY CONTROL

S = CONNECTION FOR SUCTION PIPE

R = CONNECTION FOR PROTECTIVE RELAY (EXCHANGEABLE WITH CONNECTION Q)

T = THERMOMETER BAG / TEMPERATURE SENSOR (OPTIONALLY)

SR = INSPECTION WINDOW, RIGHT

SL = INSPECTION WINDOW, LEFT

W = DRIVE SHAFT

(M) DRIVE SIDE OF SELECTOR

CONNECTIONS SWIVELING
 DIMENSIONS AND SELECTION 899496: / 899497:

DOCUMENT NO.	DATE	NAME	DOCUMENT NO.
SED 1661272 001 04	11.07.2018	BUTERUS	1086956
SCALE	CHKD.	WILHELM	PRODASTSCHUK
1:2,5	16.07.2018		

DIMENSION
 IN mm
 EXCEPT AS
 NOTED



ON-LOAD TAP-CHANGER
 OILTAP® M, MS, R, RM AND VACUTAP® VR®, VM®, VMS®
 ON-LOAD TAP-CHANGER HEAD, CENTRIC DRIVE

SERIAL NUMBER

MATERIAL NUMBER
 893899FE

SHEET
 1/1

© MASCHINENFABRIK REINHAUSEN GMBH 2016
 THE REPRODUCTION, DISTRIBUTION AND UTILIZATION OF THIS DOCUMENT AS WELL AS THE COMMUNICATION OF ITS CONTENTS TO OTHERS WITHOUT EXPRESS AUTHORIZATION IS PROHIBITED. OFFENDERS WILL BE HELD LIABLE FOR THE PAYMENT OF DAMAGES. ALL RIGHTS RESERVED IN THE EVENT OF THE GRANT OF A PATENT, UTILITY MODEL OR DESIGN.

DATE	NAME	DOCUMENT NO.
15.09.2016	RAEDLINGER	SED 4430490 000 03
CHKD. 15.09.2016	NERRETER	CHANGE NO.
STAND. 15.09.2016	PRODASTSCHUK	1077279
		SCALE
		1:5

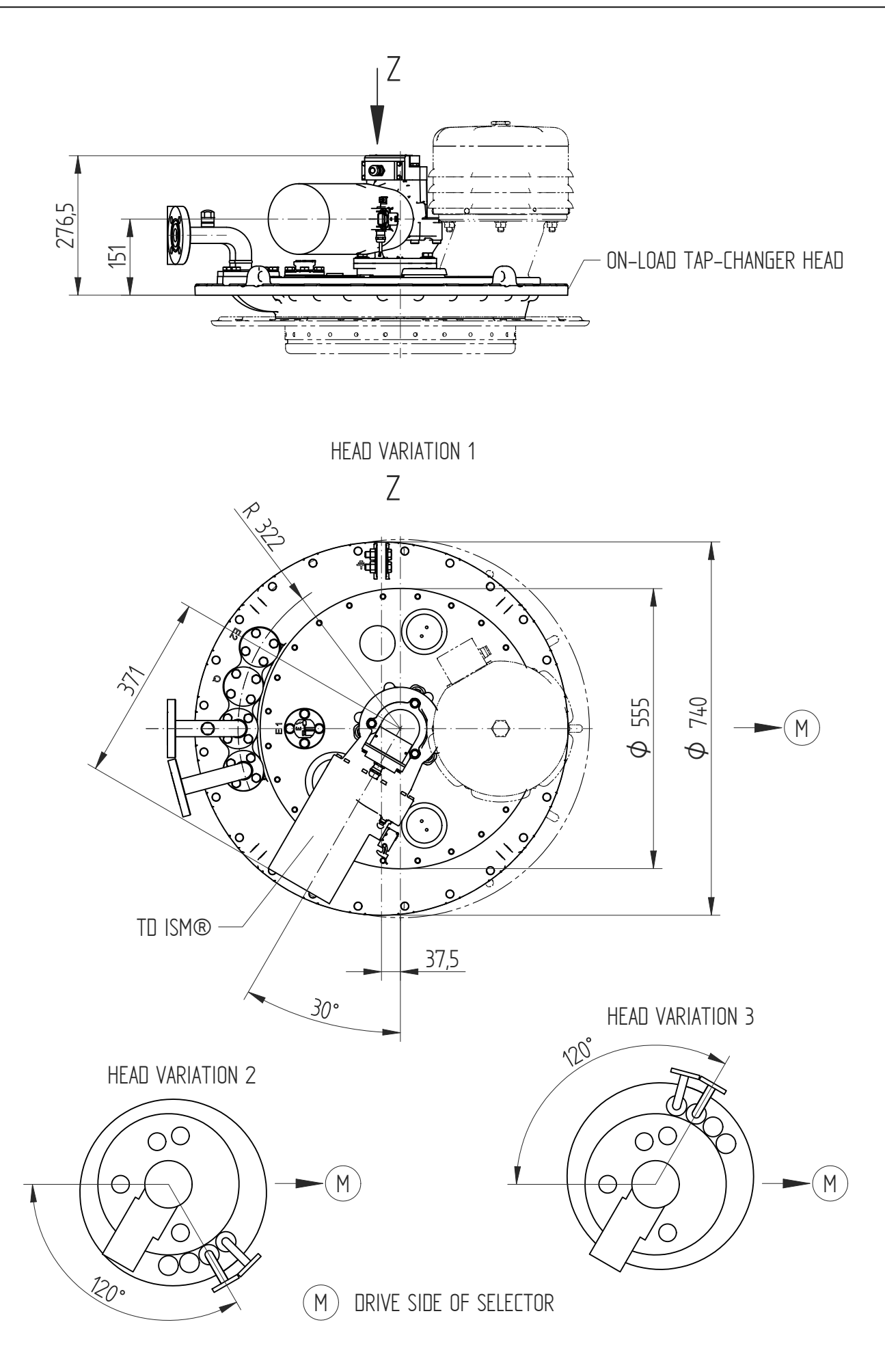

DIMENSION
 IN mm
 EXCEPT AS
 NOTED



MOTOR-DRIVE UNIT TAPMOTION® TO
 MOTOR-DRIVE UNIT TO ISM® FOR OLTC VM® AND VR
 DIMENSION DRAWING

SERIAL NUMBER	
MATERIAL NUMBER 100110232E	SHEET 1/1

© MASCHINENFABRIK REINHAUSEN GMBH 2019
 THE REPRODUCTION, DISTRIBUTION AND UTILIZATION OF THIS DOCUMENT AS WELL AS THE COMMUNICATION OF ITS CONTENTS TO OTHERS WITHOUT EXPRESS AUTHORIZATION IS PROHIBITED. OFFENDERS WILL BE HELD LIABLE FOR THE PAYMENT OF DAMAGES. ALL RIGHTS RESERVED IN THE EVENT OF THE GRANT OF A PATENT, UTILITY MODEL OR DESIGN.

Um [kV]	170 / 245 / 300	362 / 420	
DIMENSION [mm]	a	ø56	ø100
	b	148	185
	c	ø620	ø695

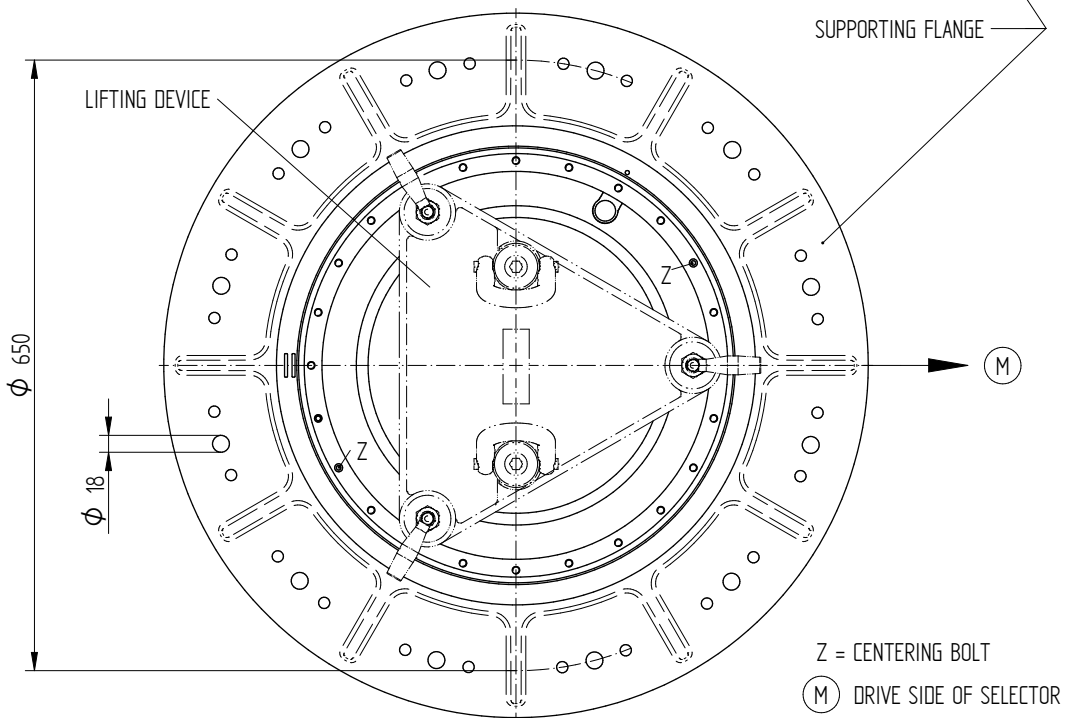
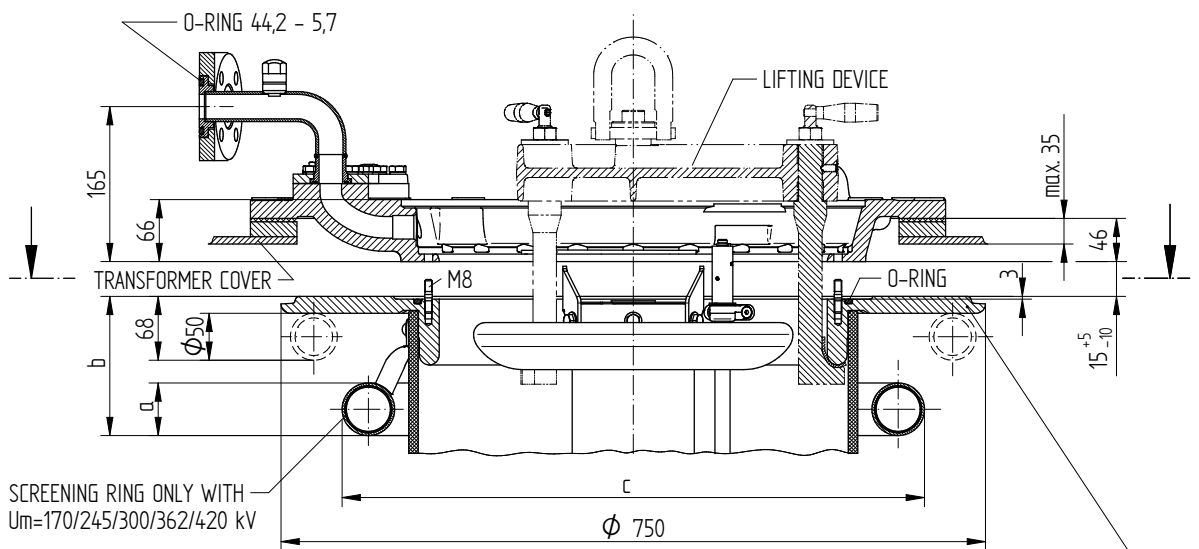
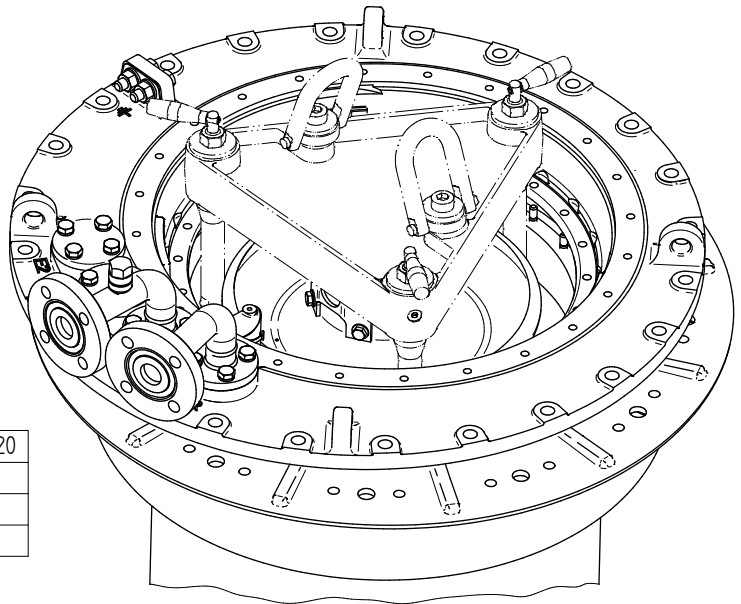

Z = CENTERING BOLT

(M) DRIVE SIDE OF SELECTOR

DATE	NAME	DOCUMENT NO.
DFTR. 15.03.2019	RAEDLINGER	SED 1324074-001 03
CHKD. 22.03.2019	NERRETER	CHANGE NO.
STAND. 25.03.2019	KLEYN	1093087

DIMENSION
IN mm
EXCEPT AS
NOTED



ON-LOAD TAP-CHANGER VACUTAP® VR
 SPECIAL DESIGN BELL-TYPE TANK INSTALLATION

SERIAL NUMBER

MATERIAL NUMBER
7207812E

SHEET
1/1

© MASCHINENFABRIK REINHAUSEN GMBH 2018
 THE REPRODUCTION, DISTRIBUTION AND UTILIZATION OF THIS DOCUMENT AS WELL AS THE COMMUNICATION OF ITS CONTENTS TO OTHERS WITHOUT EXPRESS AUTHORIZATION IS PROHIBITED. OFFENDERS WILL BE HELD LIABLE FOR THE PAYMENT OF DAMAGES. ALL RIGHTS RESERVED IN THE EVENT OF THE GRANT OF A PATENT, UTILITY MODEL OR DESIGN.

DATE	NAME	DOCUMENT NO.
11.07.2018	BUTERUS	SED 1664686 001 04
16.07.2018	WILHELM	CHANGE NO. SCALE
16.07.2018	PRODASTSCHUK	1086956 1

SKETCH	HEAD VERSION COMPONENTS USED	LIMITATION OF THE SWIVEL RANGE
	DRIVE SHAFT RIGHT HEAD VERSION 1	-180° 0° 180°
	PIPE CONNECTION R	-168° 140°
	PIPE CONNECTION S	177°
	PIPE CONNECTION Q	162°
	PIPE CONNECTION E2	147° 174°
	PRESSURE RELIEF DEVICE DV	-150° -35°
	TEMPERATURE SENSOR T	96° 175°
INSPECTION WINDOW SL / SR	-64° SL -8° 56° SR 112°	
	DRIVE SHAFT RIGHT HEAD VERSION 2	-180° 0° 180°
	PIPE CONNECTION R	-48° -21°
	PIPE CONNECTION S	-63° -36°
	PIPE CONNECTION Q	-78° -51°
	PIPE CONNECTION E2	-93° -66°
	PRESSURE RELIEF DEVICE DV	-150° -35°
	TEMPERATURE SENSOR T	96° 175°
INSPECTION WINDOW SR	56° SR 112°	
	DRIVE SHAFT RIGHT HEAD VERSION 3	-180° 0° 180°
	PIPE CONNECTION R	72° 99°
	PIPE CONNECTION S	57° 84°
	PIPE CONNECTION Q	42° 69°
	PIPE CONNECTION E2	27° 54°
	PRESSURE RELIEF DEVICE DV	-150° -35°
	TEMPERATURE SENSOR T	96° 175°
INSPECTION WINDOW SL	-64° SL -8°	
	DRIVE SHAFT LEFT HEAD VERSION 1	-180° 0° 180°
	PIPE CONNECTION R	-162° 171°
	PIPE CONNECTION S	156°
	PIPE CONNECTION Q	141° 168°
	PIPE CONNECTION E2	126° 153°
	PRESSURE RELIEF DEVICE DV	35° 150°
	TEMPERATURE SENSOR T	34° 114°
INSPECTION WINDOW SL / SR	-112° SL -56° 8° SR 64°	
	DRIVE SHAFT LEFT HEAD VERSION 2	-180° 0° 180°
	PIPE CONNECTION R	-69° -42°
	PIPE CONNECTION S	-84° -57°
	PIPE CONNECTION Q	-99° -72°
	PIPE CONNECTION E2	-114° -87°
	PRESSURE RELIEF DEVICE DV	35° 150°
	TEMPERATURE SENSOR T	34° 114°
INSPECTION WINDOW SR	8° SR 64°	
	DRIVE SHAFT LEFT HEAD VERSION 3	-180° 0° 180°
	PIPE CONNECTION R	50° 78°
	PIPE CONNECTION S	35° 62°
	PIPE CONNECTION Q	21° 48°
	PIPE CONNECTION E2	6° 33°
	PRESSURE RELIEF DEVICE DV	35° 150°
	TEMPERATURE SENSOR T	34° 114°
INSPECTION WINDOW SL	-112° SL -56°	

- LIMITATION OF THE SWIVEL RANGE THROUGH PIPE CONNECTIONS R AND S
- LIMITATION OF THE SWIVEL RANGE THROUGH OPTIONAL EXISTING PIPE CONNECTIONS Q, E2 AND PRESSURE RELIEF DEVICE DV
- SWIVEL RANGE POSSIBLE, BUT THE TEMPERATURE SENSOR T AND THE INSPECTION WINDOW SL / SR ARE NOT VISIBLE

DIMENSION
IN mm
EXCEPT AS
NOTED



ON-LOAD TAP-CHANGER
OILTAP® MS, M, RM, R AND VACUTAP® VR®, VM®, VMS®
SWIVEL RANGE OF THE GEAR UNIT

SERIAL NUMBER

MATERIAL NUMBER	SHEET
7200276E	1/1

DATE	NAME	DOCUMENT NO.
13.07.2018	BUTERUS	SED 1706827 001 05
16.07.2018	WILHELM	CHANGE NO.
16.07.2018	PRODASTSCHUK	1086956
CHKO.	SCALE	1

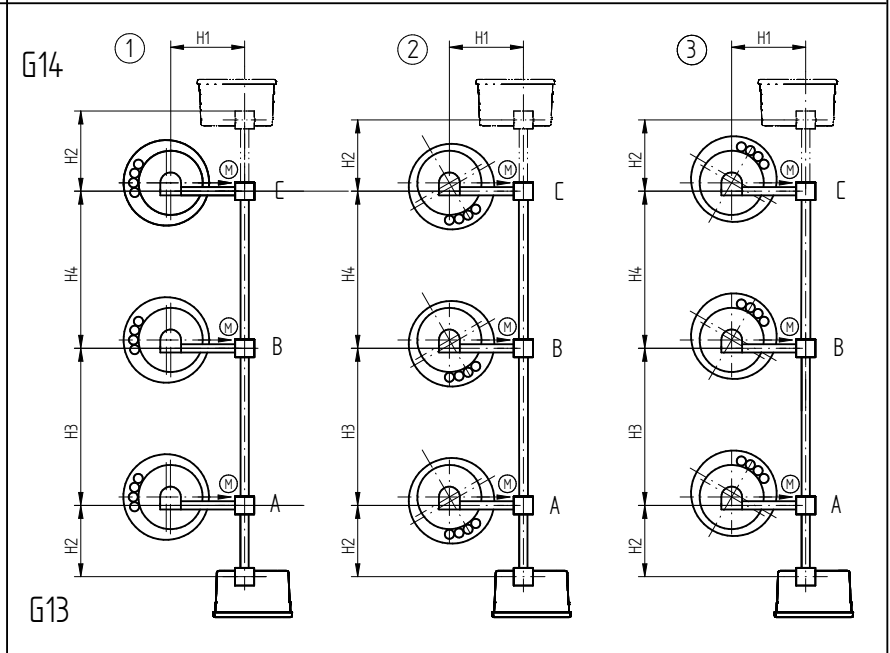
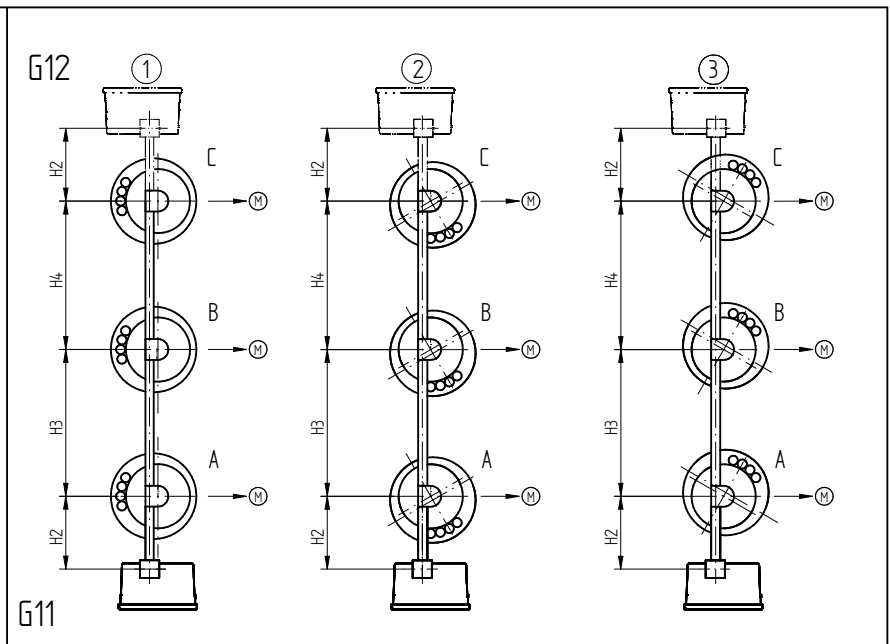
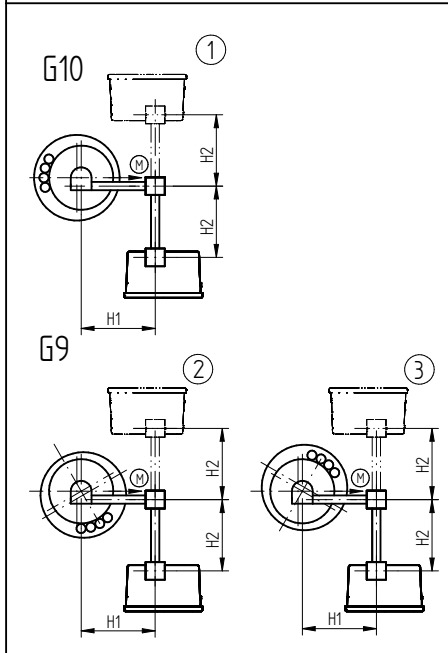
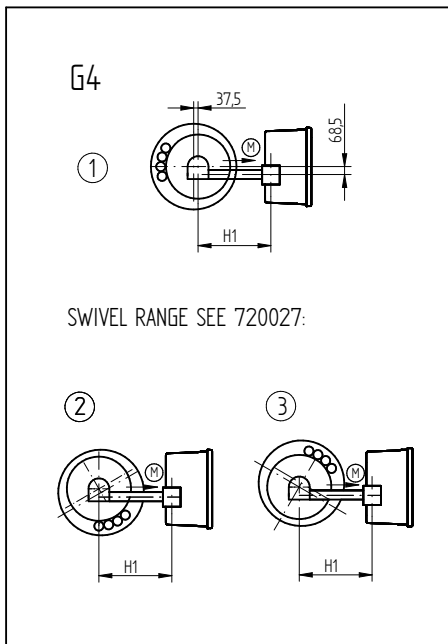

ARRANGEMENT	G4	G9, G10	G11, G12	G13, G14	
STANDARD DESIGN	■		■		
SPECIAL DESIGN		■		■	
MINIMUM DIMENSIONS ¹⁾ (DETERMINED FOR MECHANICAL REASONS; NECESSARY INSULATION SPACINGS NOT CONSIDERED!)	H1	535	545	-	545
	H2	-	323	515	323
	H3 ²⁾	-	-	840	840
	H4 ²⁾	-	-	840	840
NOTE: 1) FOR OLTCs WITH THE CHANGE-OVER SELECTOR ATTACHED Laterally, THE DIMENSIONS OF THE CHANGE-OVER SELECTOR AFTER INSTALLED IN POSITION HAVE TO BE TAKEN INTO ACCOUNT (SEE THE CORRESPONDING OLTC-DIMENSION DRAWING) 2) IN GENERAL DETERMINED BY THE INSULATION SPACING BETWEEN POLES A, B, C.					
INTERMEDIATE BEARING FOR	H1 >	2254	2309	-	2309
	H2 >	-	2259	2254	2259
	H3 >	-	-	2249	2259
	H4 >	-	-	2249	2259

① ② ③ - HEAD VERSION
 → (M) - DRIVE SIDE OF SELECTOR

DIMENSION IN mm EXCEPT AS NOTED



OLTC OILTAP® M, MS, RM, R / VACUTAP® VR®, VM®, VMS®
 HORIZONTAL DRIVE SHAFT, CENTRIC DRIVE (LIMIT DIMENSIONS)
 SELECTOR SIZE B/C/D/RC/RD/RDE

SERIAL NUMBER

MATERIAL NUMBER 893896DE
 SHEET 1/1

© MASCHINENFABRIK REINHAUSEN GMBH 2016
 THE REPRODUCTION, DISTRIBUTION AND UTILIZATION OF THIS DOCUMENT AS WELL AS THE COMMUNICATION OF ITS CONTENTS TO OTHERS WITHOUT EXPRESS AUTHORIZATION IS PROHIBITED. OFFENDERS WILL BE HELD LIABLE FOR THE PAYMENT OF DAMAGES. ALL RIGHTS RESERVED IN THE EVENT OF A PATENT, UTILITY MODEL OR DESIGN.

PIPE CONNECTION WITH TAP-CHANGE SUPERVISORY CONTROL BUSHING WITHOUT OIL FILTER UNIT

NOTICE!
 THE VENT SCREW ② OF THE MOUNTED HOUSING ① HAS TO BE ON THE TOP

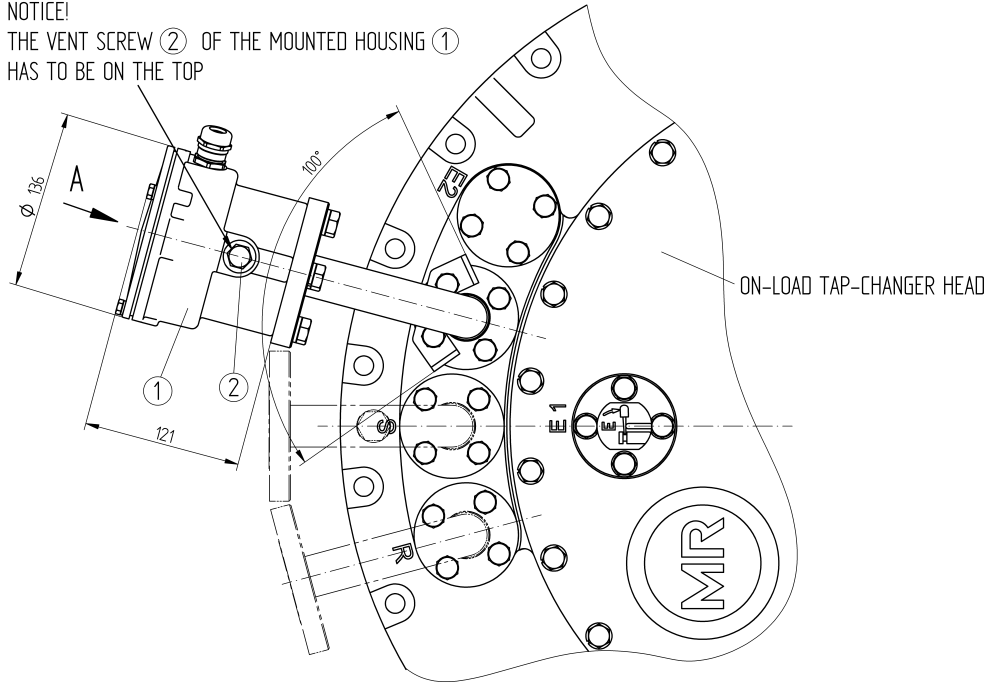

A ↻ 1:1

REPRESENTED WITHOUT COVER

M20x1.5
 CLAMPING RANGE FOR CONNECTION CABLE:
 EXTERNAL DIAMETER: 7 - 13 mm

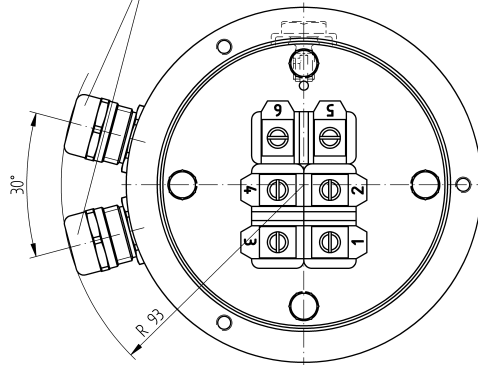

CONNECTION TERMINALS FOR TAP-CHANGE SUPERVISORY CONTROL

WIRING SEE CONNECTION DIAGRAM OF THE MOTOR-DRIVE UNIT

FUNCTION DIAGRAM FOR TAP-CHANGE SUPERVISORY CONTROL SEE MOTOR-DRIVE CONNECTION DIAGRAM

RATED CONTINUOUS CURRENT: 2A
 RATED VOLTAGE DC/AC (50HZ): 24V ... 250V
 DIELECTRIC STRENGTH: 1150V / 50HZ / 1 MIN.

DIELECTRIC TEST OF ALL VOLTAGE CARRYING TERMINALS TO GROUND:
 2000V AC , 50HZ , TEST-DURATION 1 MIN.

DATE	NAME	DOCUMENT NO.
03.11.2016	RAEDLINGER	SED 2425358 001 02
CHKD.	NERRETER	CHANGE NO.
04.11.2016	PRODASTSCHUK	1078202
STAND.		1:2

DIMENSION
 IN mm
 EXCEPT AS
 NOTED



ON-LOAD TAP-CHANGER VACUTAP® VM, VR
 PIPE CONNECTION WITH TAP-CHANGE SUPERVISORY CONTROL

SERIAL NUMBER

MATERIAL NUMBER
 7661612E

SHEET
 1/1

4.5 선택기

© MASCHINENFABRIK REINHAUSEN GMBH 2015
 THE REPRODUCTION, DISTRIBUTION AND UTILIZATION OF THIS DOCUMENT AS WELL AS THE COMMUNICATION OF ITS CONTENTS TO OTHERS WITHOUT EXPRESS AUTHORIZATION IS PROHIBITED. OFFENDERS WILL BE HELD LIABLE FOR THE PAYMENT OF DAMAGES. ALL RIGHTS RESERVED IN THE EVENT OF THE GRANT OF A PATENT, UTILITY MODEL OR DESIGN.

DATE	NAME	DOCUMENT NO.
DFTR. 06.10.2016	LIPINSKI	SED 4322131 001 01
CHKD. 19.10.2016	HILTNER	CHANGE NO.
STAND. 20.10.2016	PRODASTSCHUK	1077666
		SCALE 1:2

DIMENSION
 IN mm
 EXCEPT AS
 NOTED



SELECTOR SIZE RC/RD/RDE/RE/RF
 SELECTOR CONNECTION CONTACT
 DIMENSION DRAWING

SERIAL NUMBER

MATERIAL NUMBER
 100099170E

SHEET
 1/1

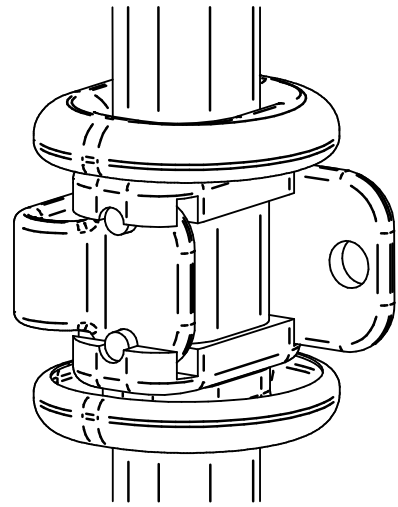
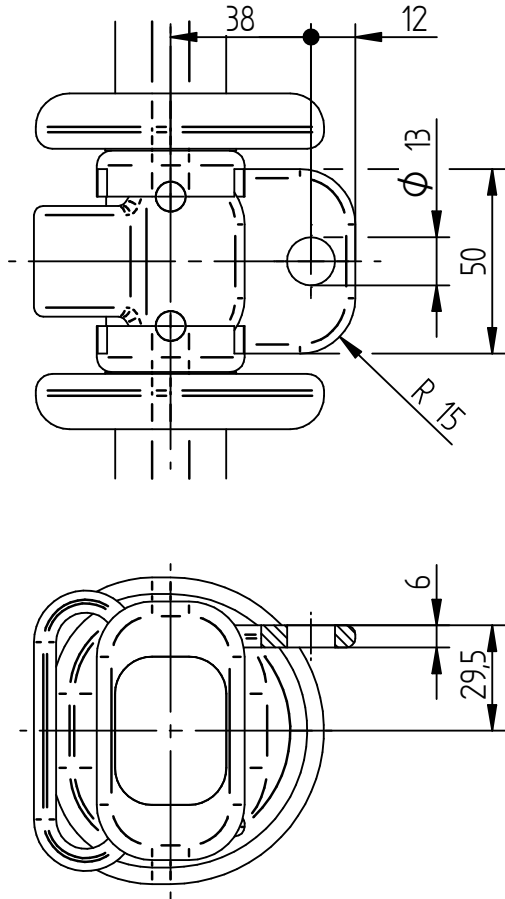

© MASCHINENFABRIK REINHAUSEN GMBH 2015
 THE REPRODUCTION, DISTRIBUTION AND UTILIZATION OF THIS DOCUMENT AS WELL AS THE COMMUNICATION OF ITS CONTENTS TO OTHERS WITHOUT EXPRESS AUTHORIZATION IS PROHIBITED. OFFENDERS WILL BE HELD LIABLE FOR THE PAYMENT OF DAMAGES. ALL RIGHTS RESERVED IN THE EVENT OF THE GRANT OF A PATENT, UTILITY MODEL OR DESIGN.

CONTACT ARRANGEMENT - WITHOUT CHANGE-OVER SELECTOR

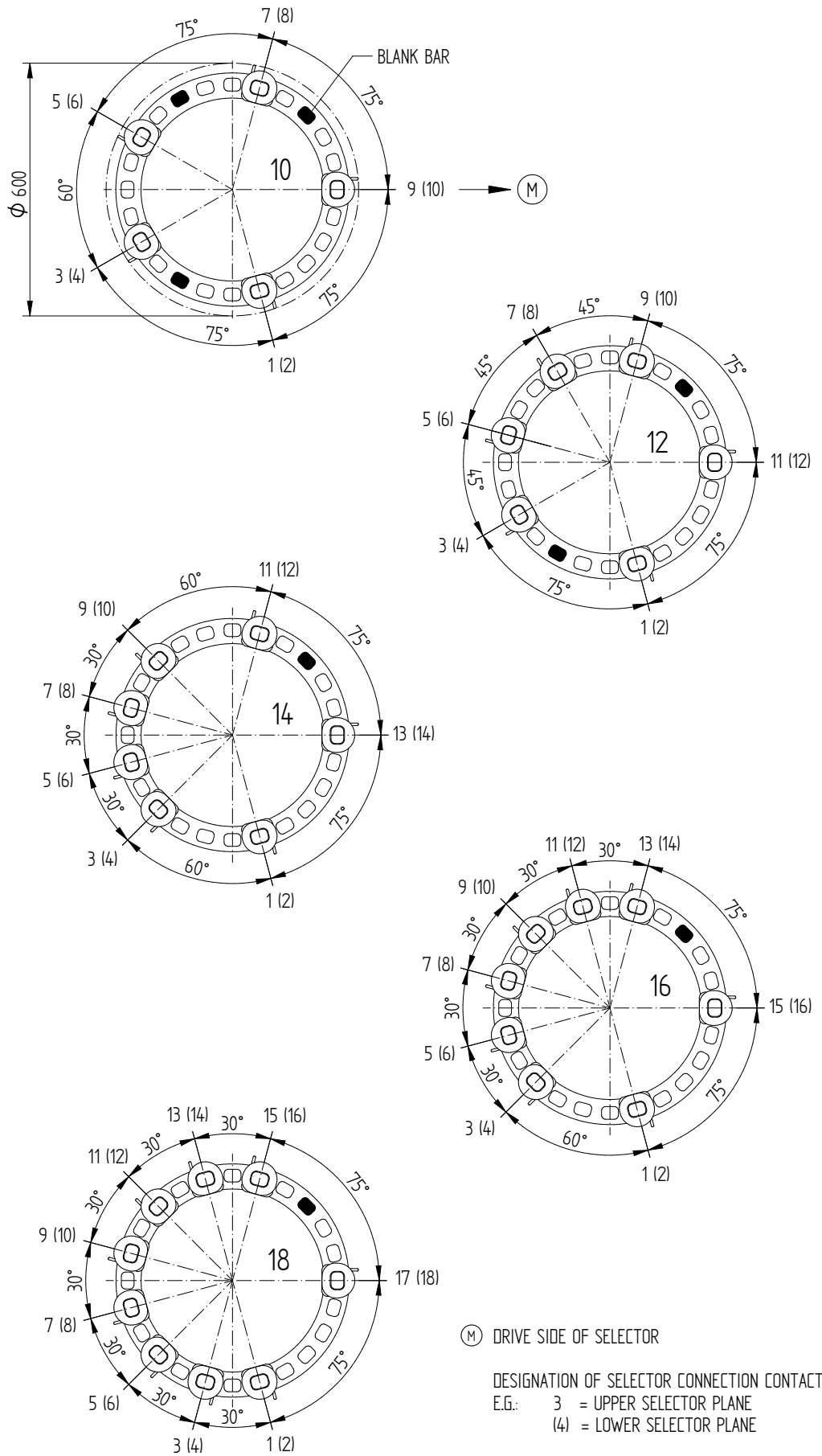

DATE	NAME	DOCUMENT NO.
18.10.2016	CTETPRAKTIK2	SED 4245760 001 01
19.10.2016	HILTNER	CHANGE NO.
20.10.2016	PRODASTSCHUK	1077666
DFTR.	SCALE	15
CHKD.		
STAND.		

DIMENSION
 IN mm
 EXCEPT AS
 NOTED



SELECTOR SIZE RC/RD/RDE
 CONTACT ARRANGEMENT
 DIMENSION DRAWING

SERIAL NUMBER

MATERIAL NUMBER 100090300E	SHEET 1/3
-------------------------------	--------------

CONTACT ARRANGEMENT - REVERSING CHANGE-OVER SELECTOR

© MASCHINENFABRIK REINHAUSEN GMBH 2015
 THE REPRODUCTION, DISTRIBUTION AND UTILIZATION OF THIS DOCUMENT AS WELL AS THE COMMUNICATION OF ITS CONTENTS TO OTHERS WITHOUT EXPRESS AUTHORIZATION IS PROHIBITED. OFFENDERS WILL BE HELD LIABLE FOR THE PAYMENT OF DAMAGES. ALL RIGHTS RESERVED IN THE EVENT OF THE GRANT OF A PATENT, UTILITY MODEL OR DESIGN.

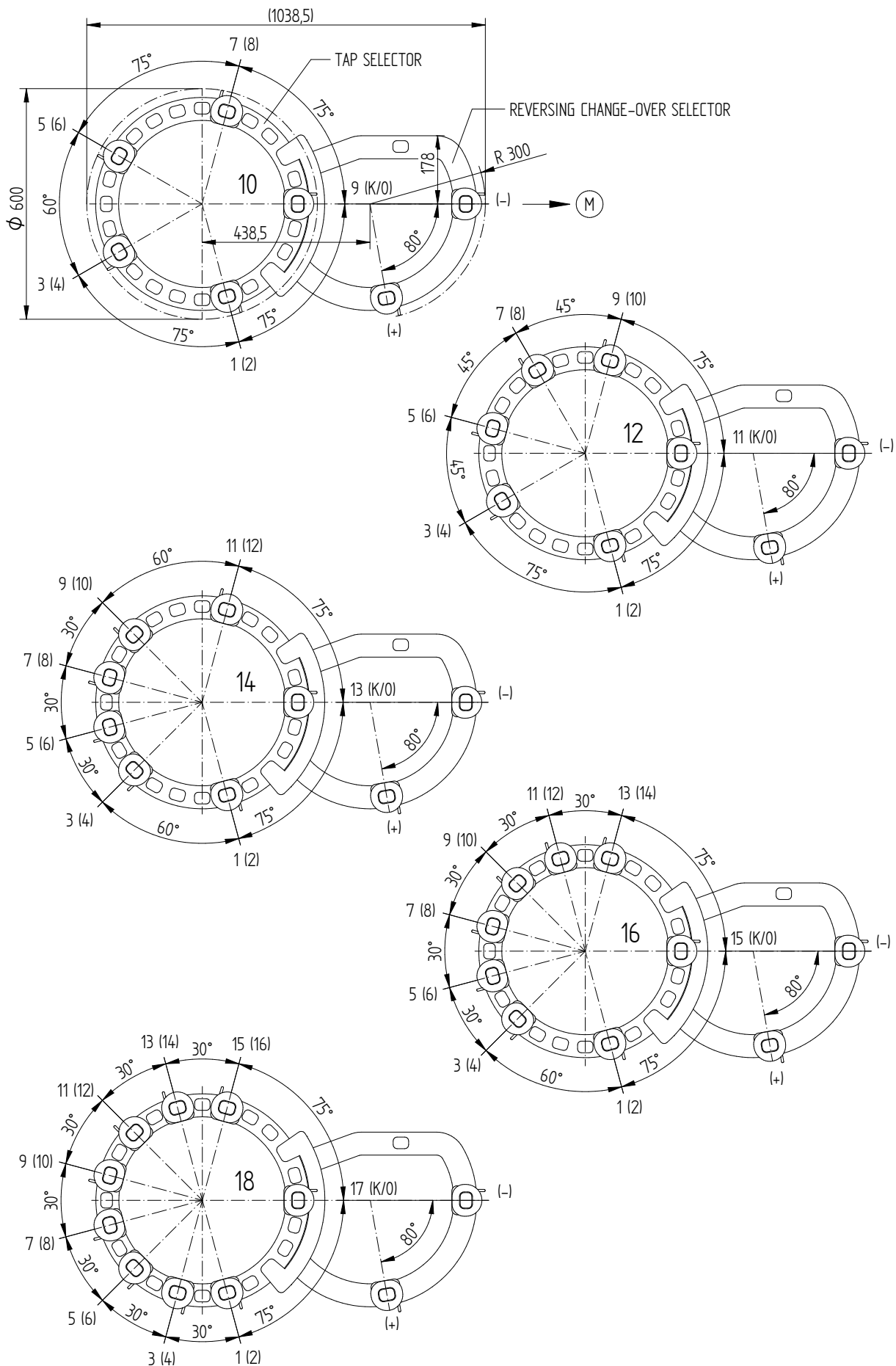

DATE	NAME	DOCUMENT NO.
18.10.2016	CTETPRAKTIK2	SED 4245760 001 01
19.10.2016	HILTNER	CHANGE NO.
20.10.2016	PRODASTSCHUK	1077666
DFTR.	SCALE	15
CHKD.		
STAND.		

DIMENSION
IN mm
EXCEPT AS
NOTED



SELECTOR SIZE RC/RD/RDE
 CONTACT ARRANGEMENT
 DIMENSION DRAWING

SERIAL NUMBER

MATERIAL NUMBER	SHEET
100090300E	2/3

CONTACT ARRANGEMENT - COARSE CHANGE-OVER SELECTOR

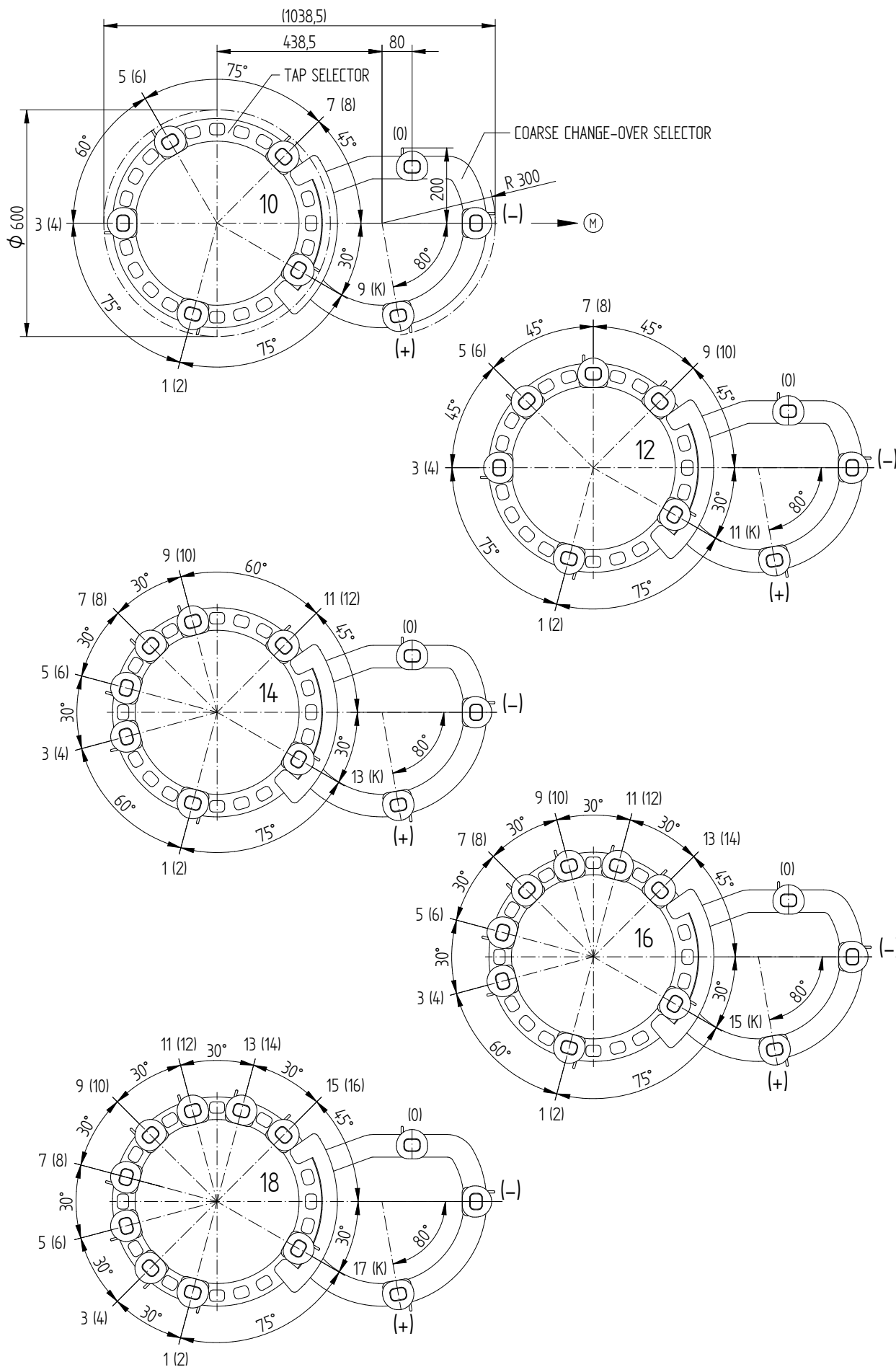

© MASCHINENFABRIK REINHAUSEN GMBH 2015
 THE REPRODUCTION, DISTRIBUTION AND UTILIZATION OF THIS DOCUMENT AS WELL AS THE COMMUNICATION OF ITS CONTENTS TO OTHERS WITHOUT EXPRESS AUTHORIZATION IS PROHIBITED. OFFENDERS WILL BE HELD LIABLE FOR THE PAYMENT OF DAMAGES. ALL RIGHTS RESERVED IN THE EVENT OF THE GRANT OF A PATENT, UTILITY MODEL OR DESIGN.

DATE	NAME	DOCUMENT NO.
18.10.2016	CTETPRAKTIK2	SED 4245760 001 01
19.10.2016	HILTNER	CHANGE NO.
20.10.2016	PRODASTSCHUK	1077666
		SCALE
		15

DIMENSION
IN mm
EXCEPT AS
NOTED



SELECTOR SIZE RC/RD/RDE
 CONTACT ARRANGEMENT
 DIMENSION DRAWING

SERIAL NUMBER

MATERIAL NUMBER	SHEET
100090300E	3/3

© MASCHINENFABRIK REINHAUSEN GMBH 2015
 THE REPRODUCTION, DISTRIBUTION AND UTILIZATION OF THIS DOCUMENT AS WELL AS THE COMMUNICATION OF ITS CONTENTS TO OTHERS WITHOUT EXPRESS AUTHORIZATION IS PROHIBITED. OFFENDERS WILL BE HELD LIABLE FOR THE PAYMENT OF DAMAGES. ALL RIGHTS RESERVED IN THE EVENT OF THE GRANT OF A PATENT, UTILITY MODEL OR DESIGN.

CONTACT ARRANGEMENT - WITHOUT CHANGE-OVER SELECTOR

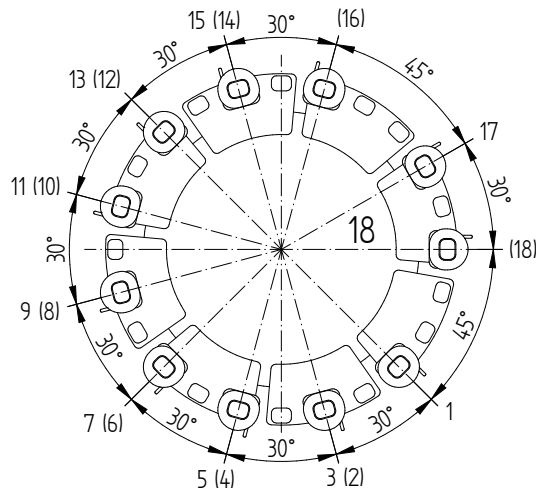
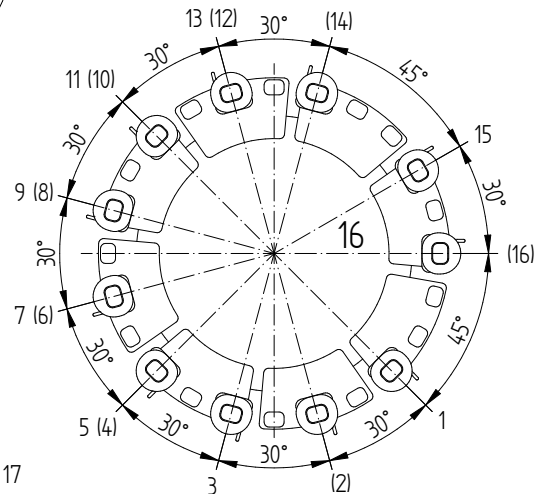
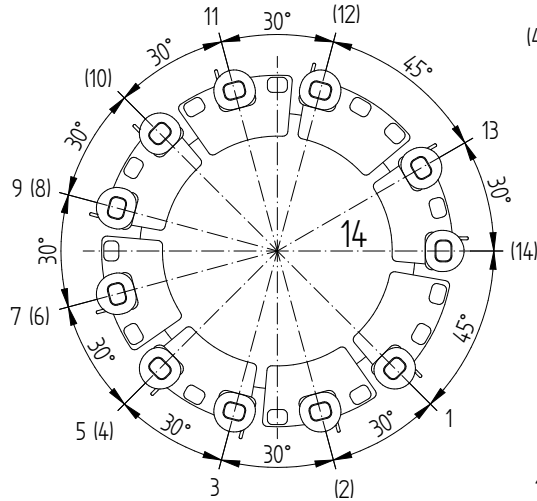
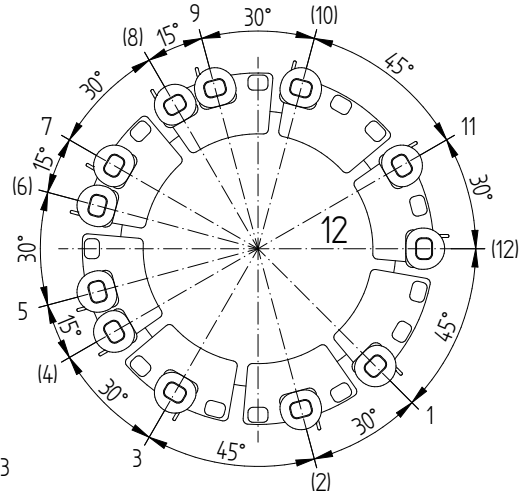
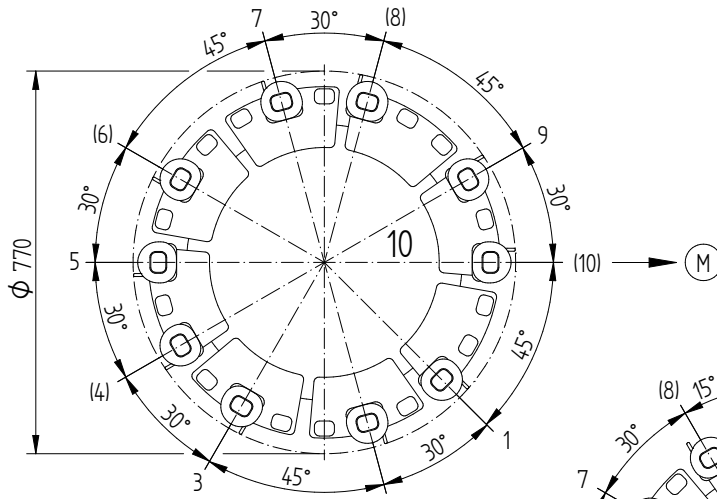

(M) DRIVE SIDE OF SELECTOR

DESIGNATION OF SELECTOR CONNECTION CONTACT
 E.G.: 3 = UPPER SELECTOR PLANE
 (4) = LOWER SELECTOR PLANE

THE DETAILED CONNECTION DIAGRAM IS BINDING FOR THE DESIGNATION OF THE CONNECTION CONTACTS AND PHASES

DATE	NAME	DOCUMENT NO.
18.10.2016	CTETPRAKTIK2	SED 5026318 001 01
19.10.2016	HILTNER	CHANGE NO.
20.10.2016	PRODASTSCHUK	1077666
		SCALE
		15

DIMENSION
 IN mm
 EXCEPT AS
 NOTED



SELECTOR SIZE RE/RF
 CONTACT ARRANGEMENT
 DIMENSION DRAWING

SERIAL NUMBER

MATERIAL NUMBER
 100165700E

SHEET
 1/3

CONTACT ARRANGEMENT - REVERSING CHANGE-OVER SELECTOR

© MASCHINENFABRIK REINHAUSEN GMBH 2015
 THE REPRODUCTION, DISTRIBUTION AND UTILIZATION OF THIS DOCUMENT AS WELL AS THE COMMUNICATION OF ITS CONTENTS TO OTHERS WITHOUT EXPRESS AUTHORIZATION IS PROHIBITED. OFFENDERS WILL BE HELD LIABLE FOR THE PAYMENT OF DAMAGES. ALL RIGHTS RESERVED IN THE EVENT OF THE GRANT OF A PATENT, UTILITY MODEL OR DESIGN.

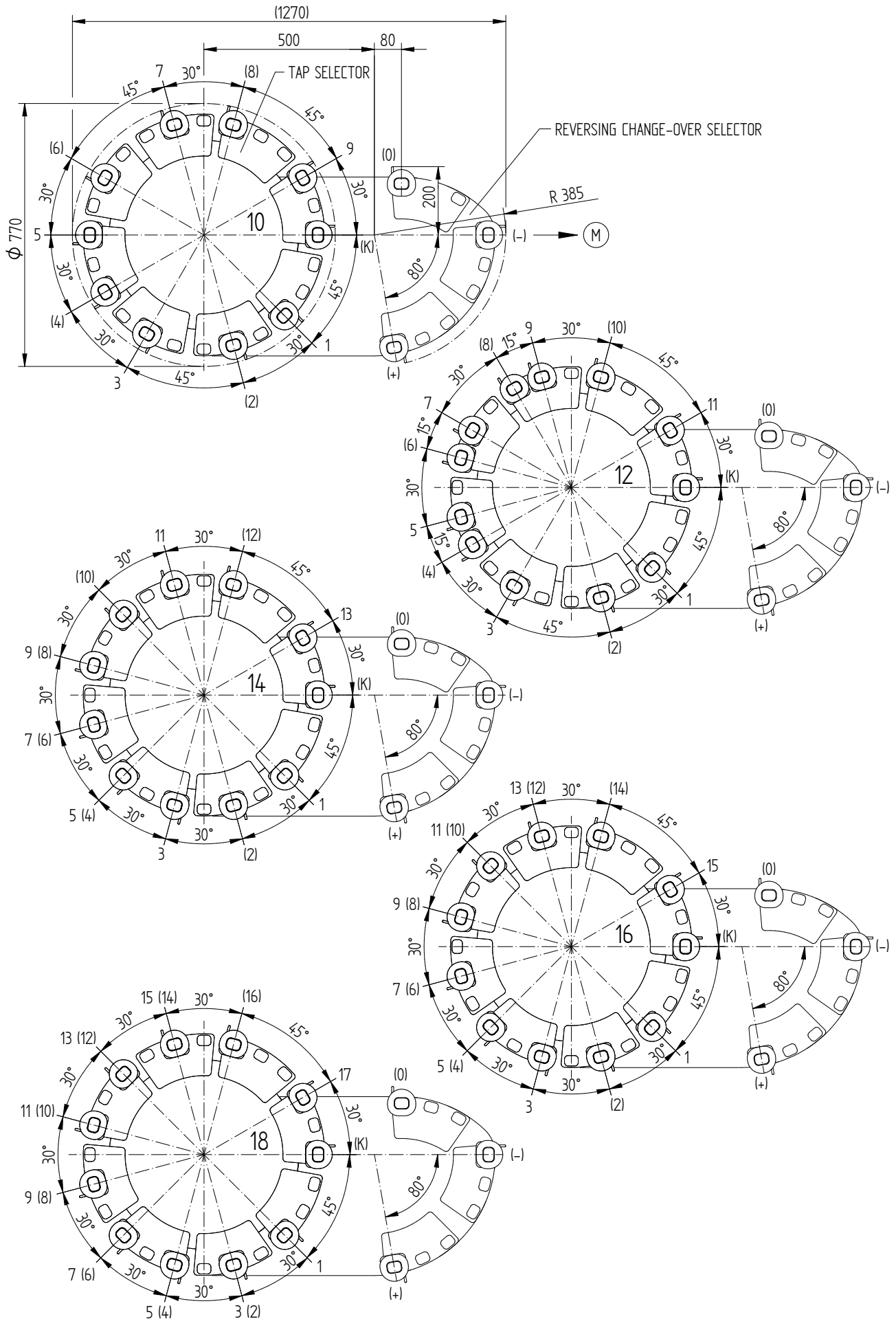

DATE	NAME	DOCUMENT NO.
18.10.2016	CTETPRAKTIK2	SED 5026318 001 01
19.10.2016	HILTNER	CHANGE NO.
20.10.2016	PRODASTSCHUK	1077666
DFTR.	SCALE	15
CHKD.		
STAND.		

DIMENSION
IN mm
EXCEPT AS
NOTED



SELECTOR SIZE RE/RF
 CONTACT ARRANGEMENT
 DIMENSION DRAWING

SERIAL NUMBER	
MATERIAL NUMBER	SHEET
100165700E	2/3

© MASCHINENFABRIK REINHAUSEN GMBH 2015
 THE REPRODUCTION, DISTRIBUTION AND UTILIZATION OF THIS DOCUMENT AS WELL AS THE COMMUNICATION OF ITS CONTENTS TO OTHERS WITHOUT EXPRESS AUTHORIZATION IS PROHIBITED. OFFENDERS WILL BE HELD LIABLE FOR THE PAYMENT OF DAMAGES. ALL RIGHTS RESERVED IN THE EVENT OF THE GRANT OF A PATENT, UTILITY MODEL OR DESIGN.

CONTACT ARRANGEMENT - COARSE CHANGE-OVER SELECTOR

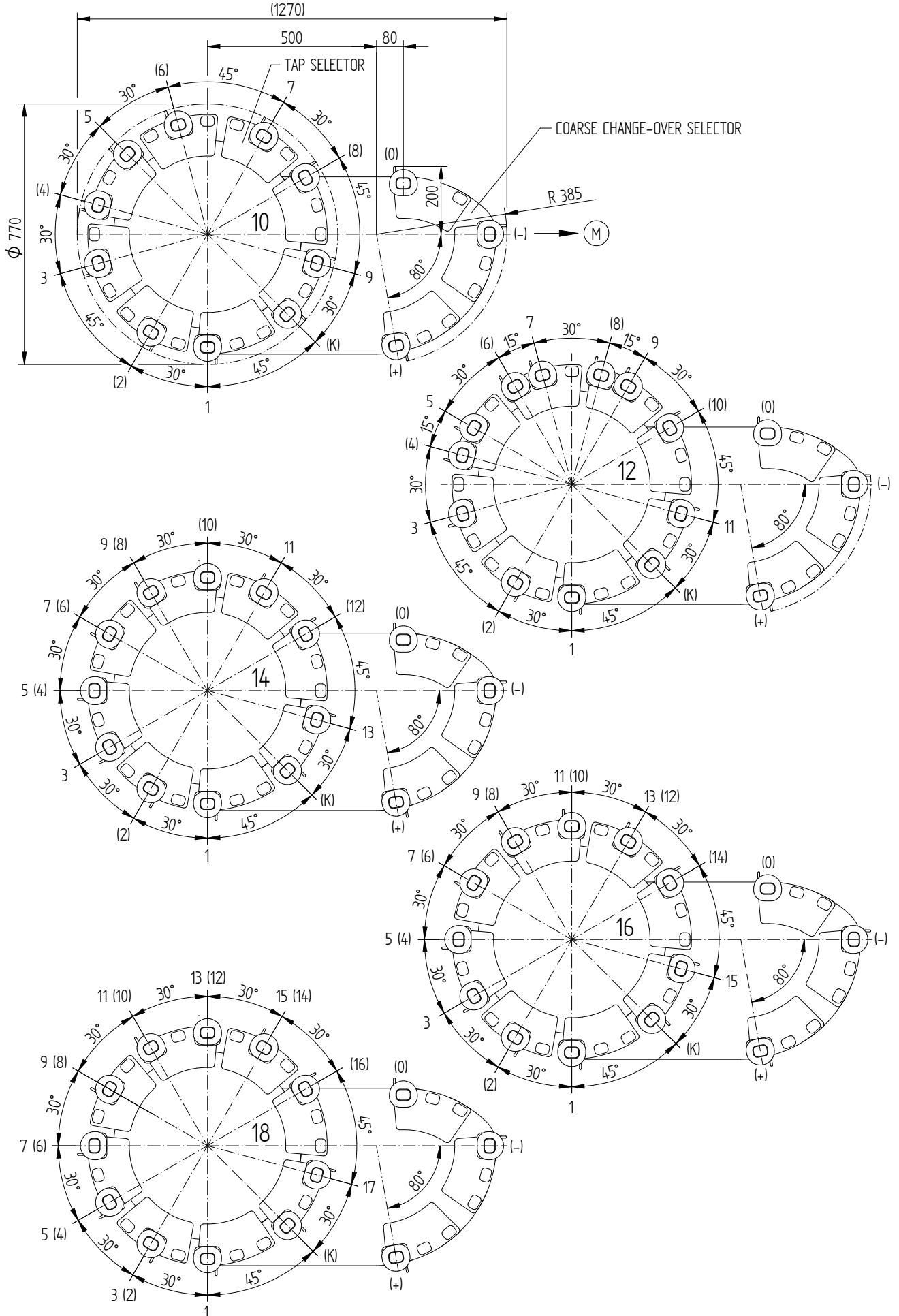

DATE	NAME	DOCUMENT NO.
18.10.2016	CTETPRAKTIK2	SED 5026318 001 01
19.10.2016	HILTNER	CHANGE NO.
20.10.2016	PRODASTSCHUK	1077666
		SCALE
		15

DIMENSION
 IN mm
 EXCEPT AS
 NOTED



SELECTOR SIZE RE/RF
 CONTACT ARRANGEMENT
 DIMENSION DRAWING

SERIAL NUMBER	
MATERIAL NUMBER	SHEET
100165700E	3/3

© MASCHINENFABRIK REINHAUSEN GMBH 2015
 THE REPRODUCTION, DISTRIBUTION AND UTILIZATION OF THIS DOCUMENT AS WELL AS THE COMMUNICATION OF ITS CONTENTS TO OTHERS WITHOUT EXPRESS AUTHORIZATION IS PROHIBITED. OFFENDERS WILL BE HELD LIABLE FOR THE PAYMENT OF DAMAGES. ALL RIGHTS RESERVED IN THE EVENT OF THE GRANT OF A PATENT, UTILITY MODEL OR DESIGN.

SELECTOR WITHOUT CHANGE-OVER SELECTOR:

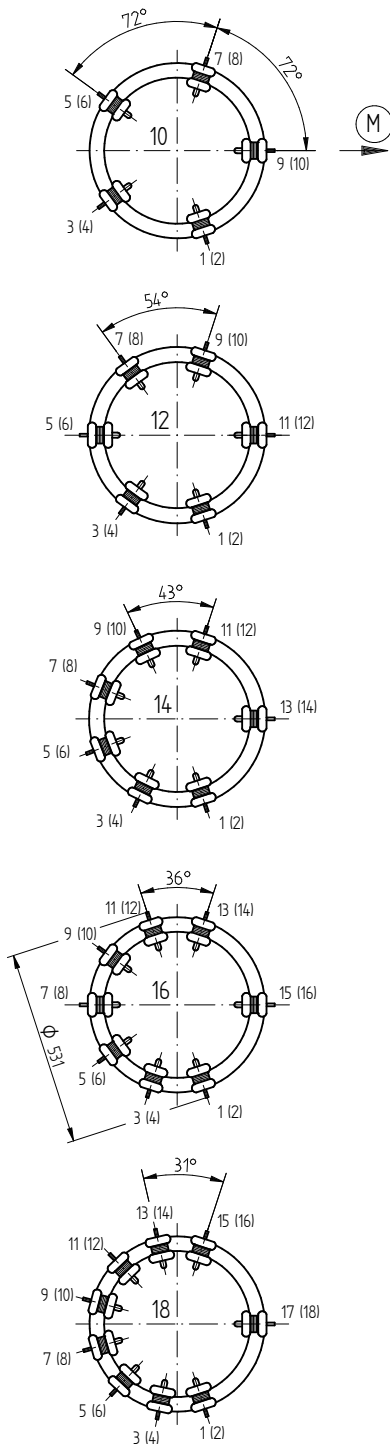

SELECTOR WITH REVERSING CHANGE-OVER SELECTOR:

REPRESENTATION APPLIES TO 3-PHASES Y-DESIGN AND 2-PHASES IN 1-PHASE SELECTORS THE UPPER AND LOWER SELECTOR PLANE ARE INTERCHANGED

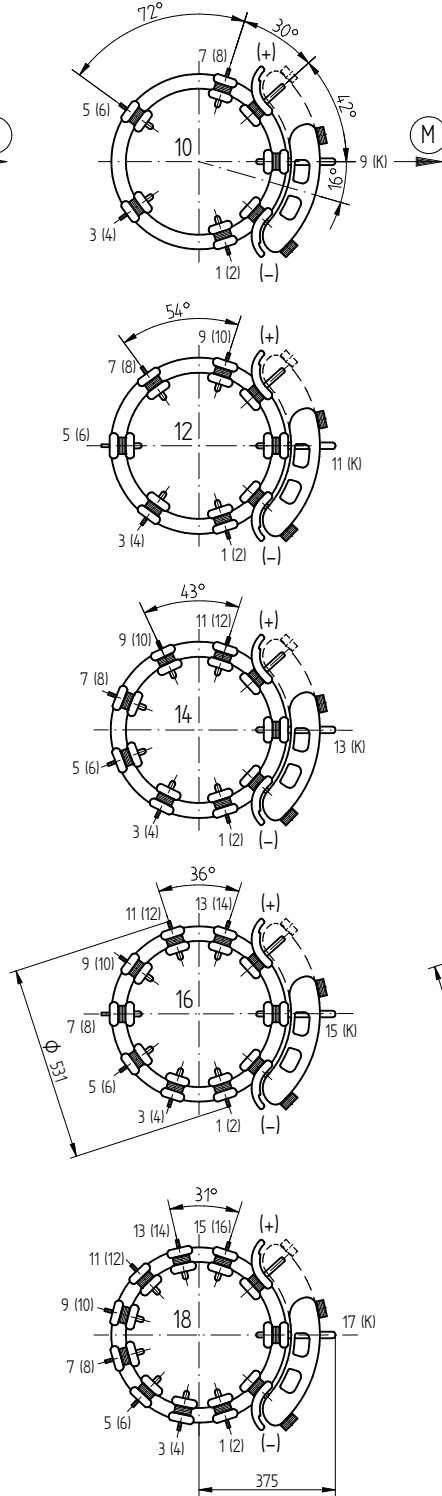

SELECTOR WITH COARSE CHANGE-OVER SELECTOR:

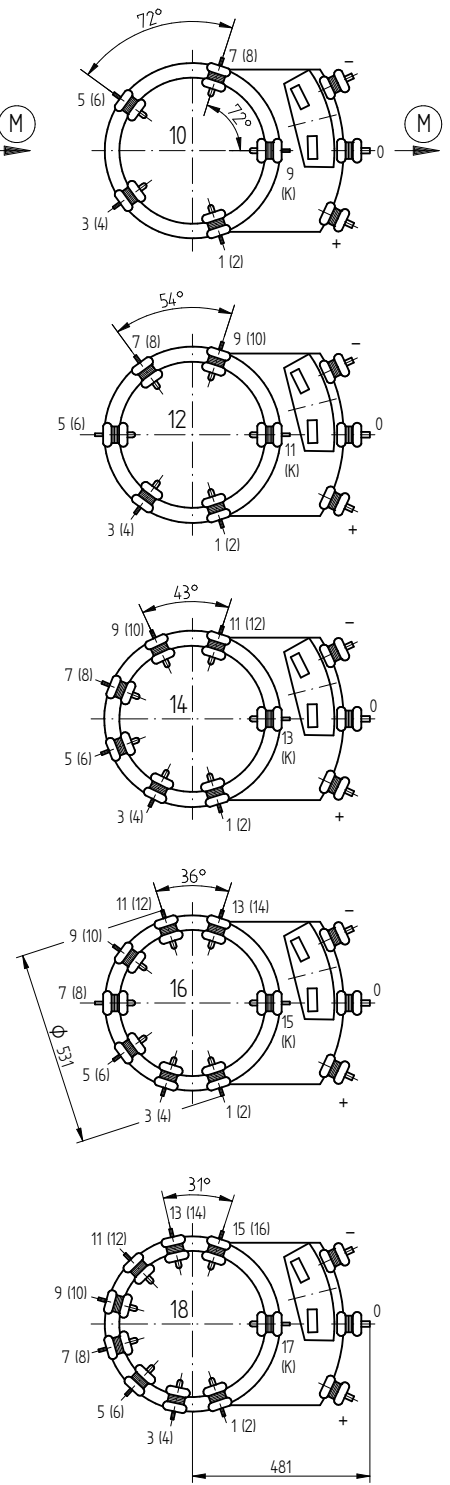

(M) - DRIVE SIDE OF SELECTOR

THE DETAILED CONNECTION DIAGRAM IS BINDING FOR THE DESIGNATION OF THE SELECTOR CONNECTION CONTACTS

DESIGNATION OF SELECTOR CONNECTION CONTACTS
 E.G.: 3 UPPER CONTACT PLANE
 (4) LOWER CONTACT PLANE

DATE	18.10.2016	DOCUMENT NO.	SED 5165932 001 00
DFTR.	19.10.2016	NAME	CTETPRAKTIK2
CHKD.	19.10.2016	SCALE	1:10
STAND.	19.10.2016	CHANGE NO.	1077668
		PRODASTSCHUK	

DIMENSION
 IN mm
 EXCEPT AS
 NOTED



ON-LOAD TAP-CHANGER VACUTAP® VR
 VR S/M - ARRANGEMENT OF CONTACTS - SELECTOR SIZE B/C/D/DE
 DIMENSION DRAWING

SERIAL NUMBER	
-	
MATERIAL NUMBER	SHEET
100180460E	1/1

MASCHINENFABRIK REINHAUSEN GMBH COPYRIGHT RESERVED
 THE REPRODUCTION, DISTRIBUTION AND UTILIZATION OF THIS DOCUMENT AS WELL AS THE COMMUNICATION OF ITS CONTENTS TO OTHERS WITHOUT EXPRESS AUTHORIZATION IS PROHIBITED. OFFENDERS WILL BE HELD LIABLE FOR THE PAYMENT OF DAMAGES. ALL RIGHTS RESERVED IN THE EVENT OF THE GRANT OF A PATENT, UTILITY MODEL OR DESIGN.

DATE	08.02.2021	DOCUMENT NO.	SED 7921643 000 00
NAME	MENZELS	CHANGE NO.	1106396
SCALE	1:2		
CHKO.	08.02.2021		
STAND.	08.02.2021		

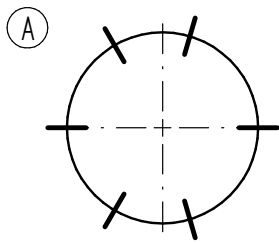
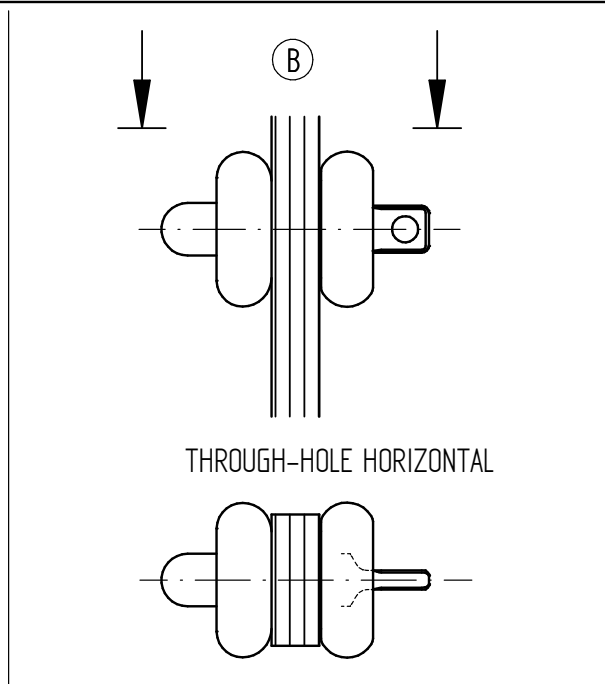
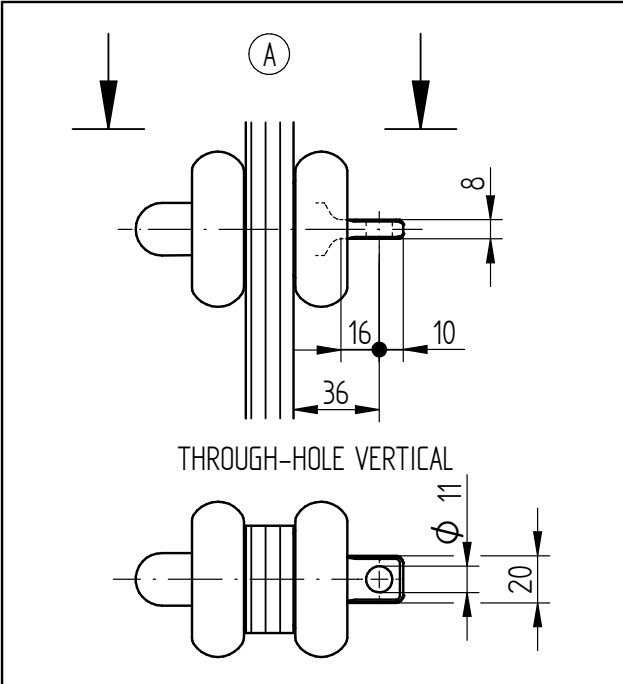

VRS/ VRM III 700 - 0
 VRS/ VRM I 701 - 0
 VRS/ VRM II 702 - 0

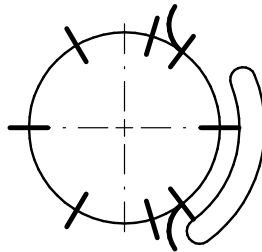

VRS/ VRM III 700 - W
 VRS/ VRM I 701 - W
 VRS/ VRM II 702 - W

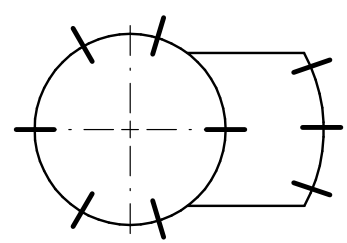

VRS/ VRM III 700 - G
 VRS/ VRM I 701 - G
 VRS/ VRM II 702 - G

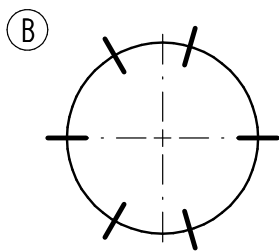

VRS/ VRM I 1001 - 0
 VRS/ VRM I 1301 - 0

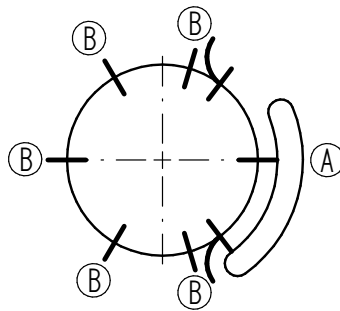

VRS/ VRM I 1001 - W
 VRS/ VRM I 1301 - W

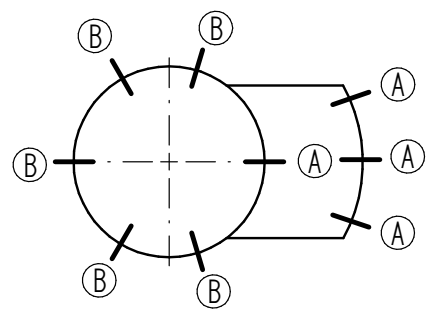

VRS/ VRM I 1001 - G
 VRS/ VRM I 1301 - G

(A) + (B)

DIMENSION
IN mm
EXCEPT AS
NOTED



DE-ENERGIZED TAP-CHANGER VACUTAP® VR®
 VRS/ VRM - B/ C/ D/ DE
 INSTALLATION POSITION OF THE TAP SELECTOR CONTACT TERMINALS

SERIAL NUMBER

MATERIAL NUMBER
101357420E

SHEET
1 / 1

© MASCHINENFABRIK REINHAUSEN GMBH 2015
 THE REPRODUCTION, DISTRIBUTION AND UTILIZATION OF THIS DOCUMENT AS WELL AS THE COMMUNICATION OF ITS CONTENTS TO OTHERS WITHOUT EXPRESS AUTHORIZATION IS PROHIBITED. OFFENDERS WILL BE HELD LIABLE FOR THE PAYMENT OF DAMAGES. ALL RIGHTS RESERVED IN THE EVENT OF THE GRANT OF A PATENT, UTILITY MODEL OR DESIGN.

REVERSING CHANGE-OVER SELECTOR

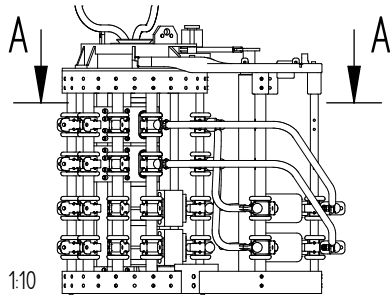

A-A

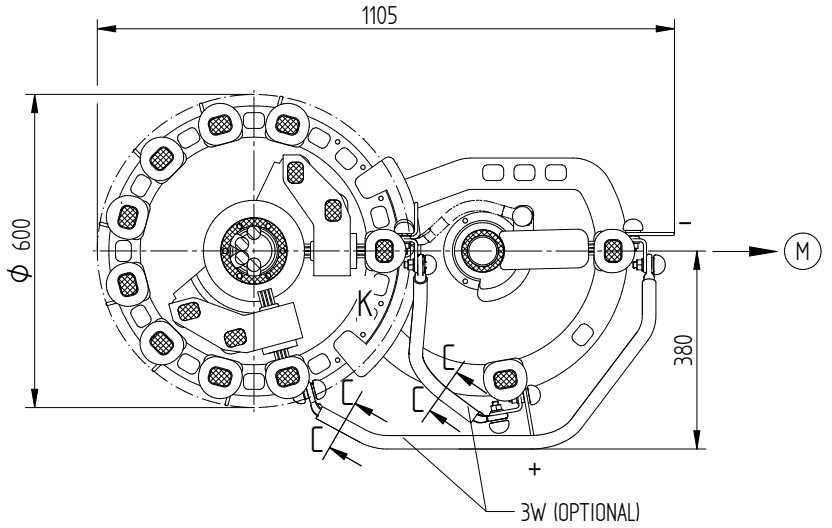

COARSE CHANGE-OVER SELECTOR

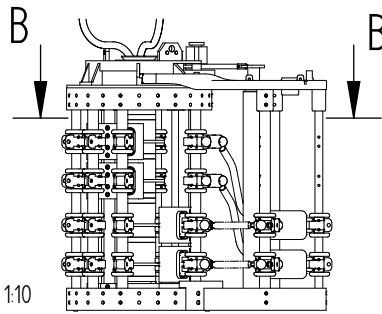

B-B

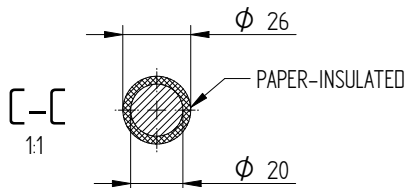
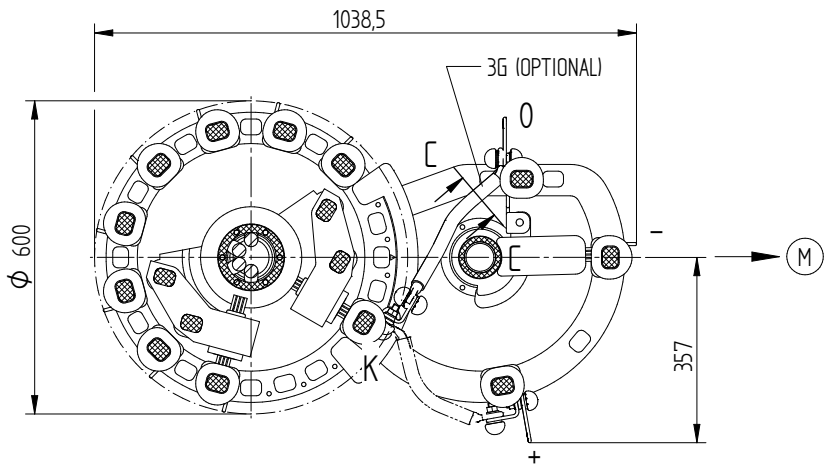

(M) DRIVE SIDE OF SELECTOR

THE DETAILED CONNECTION DIAGRAM IS BINDING FOR THE DESIGNATION OF THE CONNECTION CONTACTS AND PHASES

DATE	NAME	DOCUMENT NO.
DFTR. 18.10.2016	CTETPRAKTIK2	SED 4335433 001 02
CHKD. 19.10.2016	HILFNER	CHANGE NO.
STAND. 20.10.2016	PRODASTSCHUK	1077666
		SCALE 15

DIMENSION IN mm EXCEPT AS NOTED



SELECTOR SIZE RC/RD/RDE
 CONNECTING LEAD 3W/3G
 DIMENSION DRAWING

SERIAL NUMBER

MATERIAL NUMBER 100100190E
 SHEET 1/1

© MASCHINENFABRIK REINHAUSEN GMBH 2016
 THE REPRODUCTION, DISTRIBUTION AND UTILIZATION OF THIS DOCUMENT AS WELL AS THE COMMUNICATION OF ITS CONTENTS TO OTHERS WITHOUT EXPRESS AUTHORIZATION IS PROHIBITED. OFFENDERS WILL BE HELD LIABLE FOR THE PAYMENT OF DAMAGES. ALL RIGHTS RESERVED IN THE EVENT OF THE GRANT OF A PATENT, UTILITY MODEL OR DESIGN.

REVERSING CHANGE-OVER SELECTOR

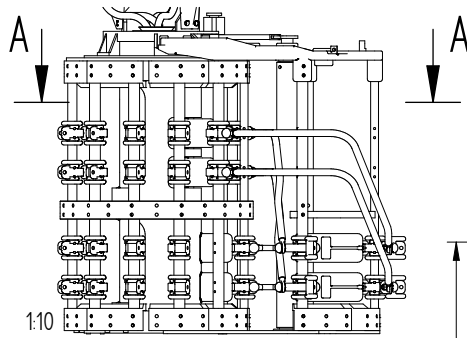

A-A

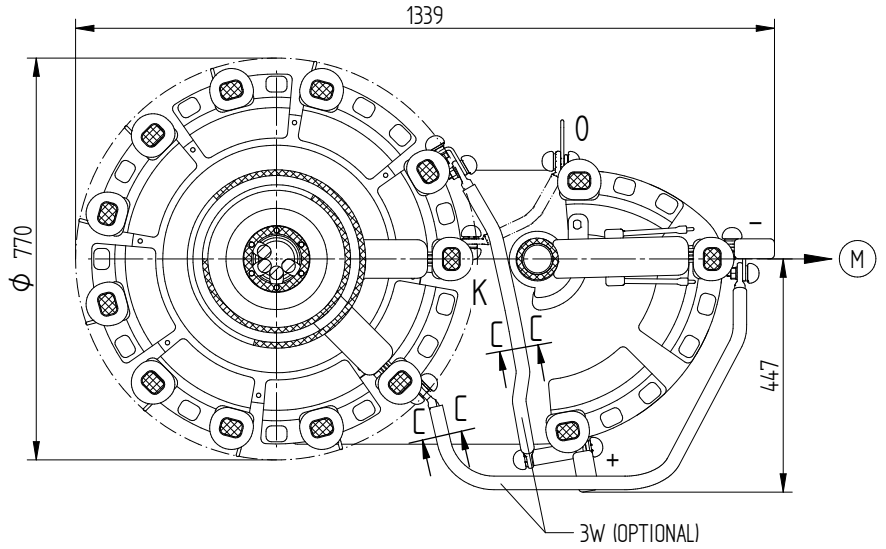

COARSE CHANGE-OVER SELECTOR

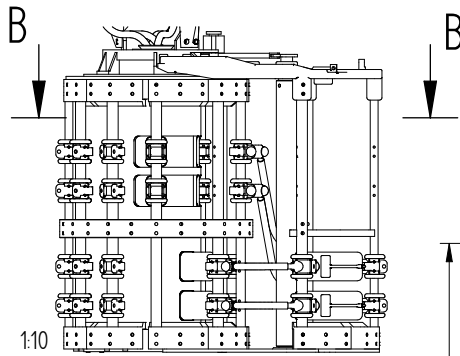

B-B

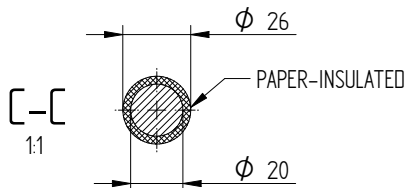
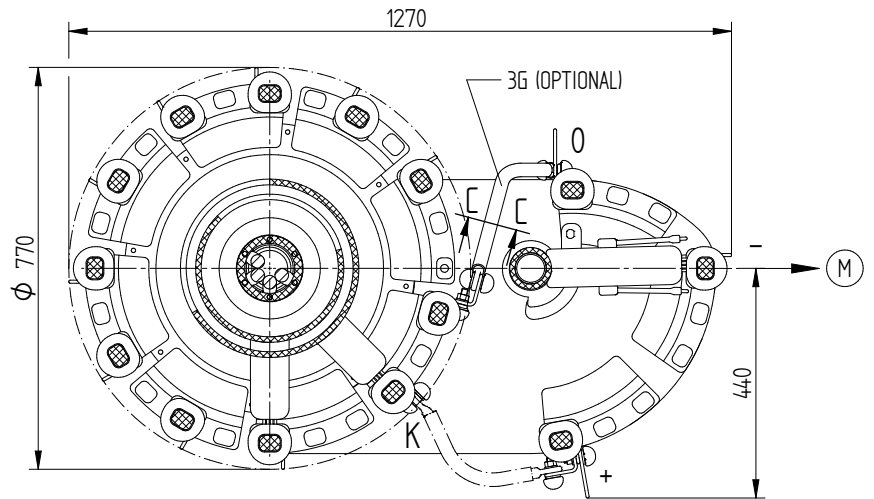

(M) DRIVE SIDE OF SELECTOR

THE DETAILED CONNECTION DIAGRAM IS BINDING FOR THE DESIGNATION OF THE CONNECTION CONTACTS AND PHASES

DATE	19.10.2016	DOCUMENT NO.	SED 5089626 001 02
DFTR.	CTETPRAKTIK2	NAME	HILTNER
CHKD.	20.10.2016	CHANGE NO.	1077337
STAND.	20.10.2016	SCALE	15
		PRODASTSCHUK	

DIMENSION
 IN mm
 EXCEPT AS
 NOTED



SELECTOR SIZE RE/RF
 CONNECTING LEAD 3W/3G
 DIMENSION DRAWING

SERIAL NUMBER

MATERIAL NUMBER
 100172640E

SHEET
 1/1

© MASCHINENFABRIK REINHAUSEN GMBH 2018
 THE REPRODUCTION, DISTRIBUTION AND UTILIZATION OF THIS DOCUMENT AS WELL AS THE COMMUNICATION OF ITS CONTENTS TO OTHERS WITHOUT EXPRESS AUTHORIZATION IS PROHIBITED. OFFENDERS WILL BE HELD LIABLE FOR THE PAYMENT OF DAMAGES. ALL RIGHTS RESERVED IN THE EVENT OF THE GRANT OF A PATENT, UTILITY MODEL OR DESIGN.

REVERSING CHANGE-OVER SELECTOR

E - F (TYPE M / VM / VMS-C) AND D - D (TYPE VRC / VRE / VRC I HD / VRE I HD / VRS / VRM)
 REPRESENTATION APPLIES TO 12-PITCH SELECTOR

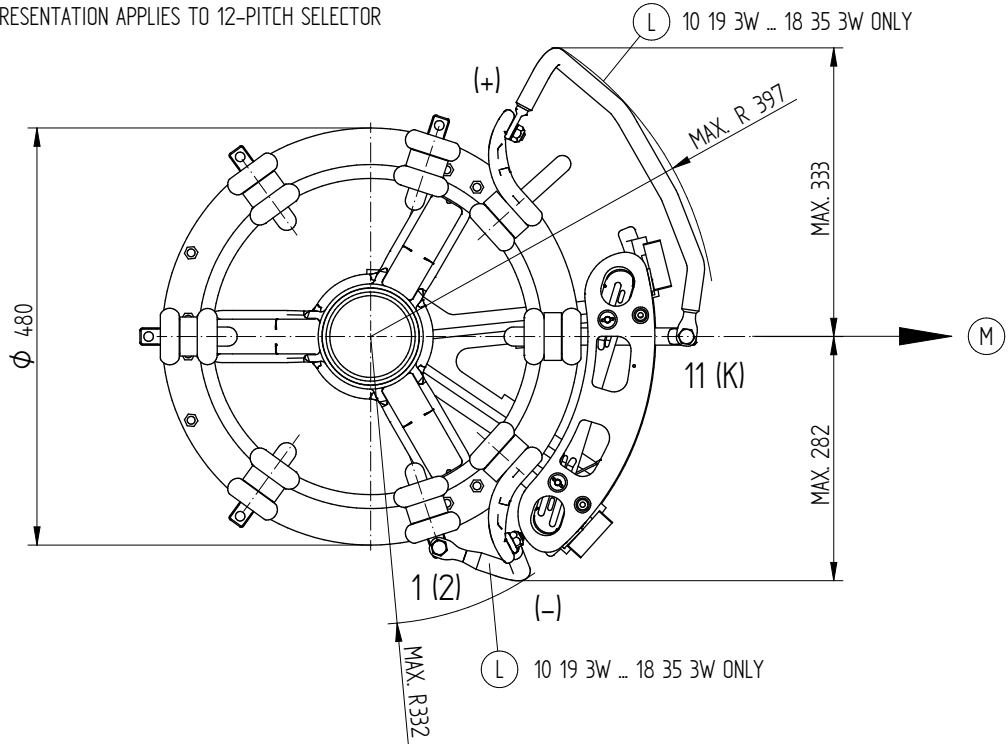

COARSE CHANGE-OVER SELECTOR

G - H (TYPE M / VM / VMS-C) AND E - E (TYPE VRC / VRE / VRC I HD / VRE I HD / VRS / VRM)
 REPRESENTATION APPLIES TO 12-PITCH SELECTOR

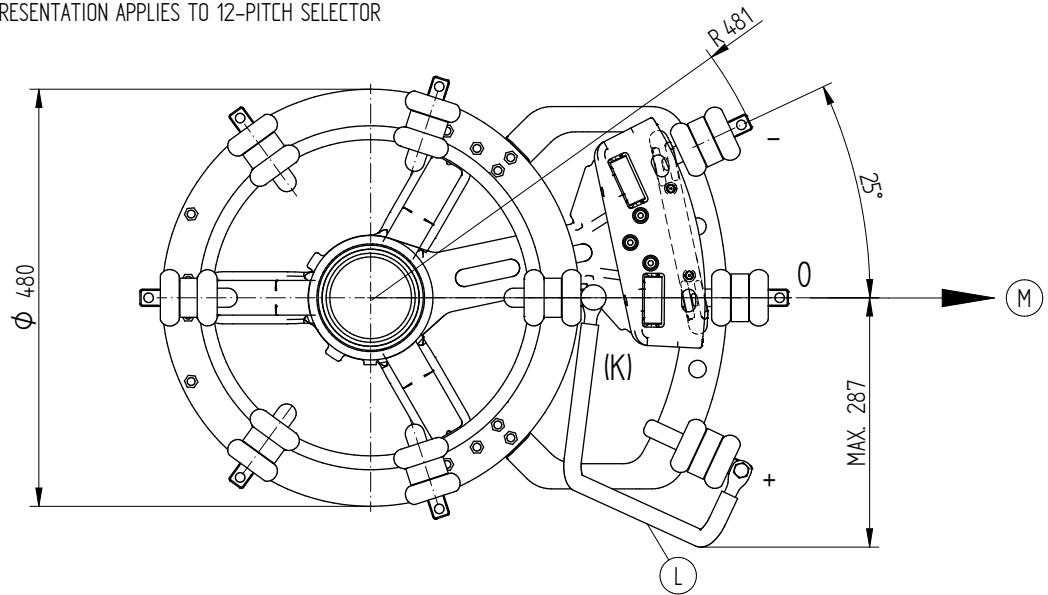

(L) SELECTOR SIZE B, C, D

(L) SELECTOR SIZE DE

(M) DRIVE SIDE OF SELECTOR

(L) CONNECTING LEADS

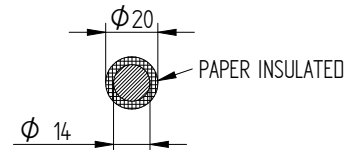
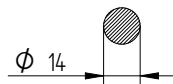

THE DETAILED CONNECTION DIAGRAM IS BINDING FOR THE DESIGNATION OF THE CONNECTION CONTACTS

DATE	NAME	DOCUMENT NO.
DFTR. 13.07.2018	BUTERUS	SED 1474939 000 06
CHKD. 16.07.2018	WILHELM	CHANGE NO.
STAND. 16.07.2018	PRODASTSCHUK	1086956
		SCALE 1:3

DIMENSION
IN mm
EXCEPT AS
NOTED



OLT C OILTAP® M / VACUTAP® VM®, VMS®-C, VRC, VRE, VRS, VRM
 CONNECTING LEAD 3W AND 1G / 3G
 M-SELECTOR SIZE B/C/D/DE

SERIAL NUMBER

MATERIAL NUMBER
7235904E

SHEET
1/1

© MASCHINENFABRIK REINHAUSEN GMBH 2018
 THE REPRODUCTION, DISTRIBUTION AND UTILIZATION OF THIS DOCUMENT AS WELL AS THE COMMUNICATION OF ITS CONTENTS TO OTHERS WITHOUT EXPRESS AUTHORIZATION IS PROHIBITED. OFFENDERS WILL BE HELD LIABLE FOR THE PAYMENT OF DAMAGES. ALL RIGHTS RESERVED IN THE EVENT OF A PATENT, UTILITY MODEL OR DESIGN.

ARRANGEMENT OF CONTACT B

VRS I 1001
VRM I 1001

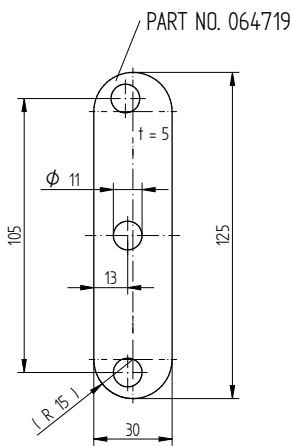

VRS I 1301
VRM I 1301

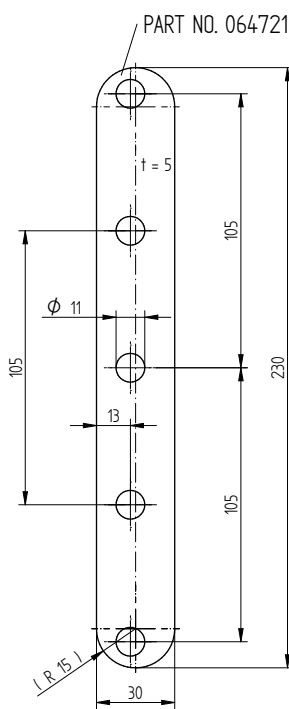

ARRANGEMENT OF CONTACT A

VRS I 1001 / 1301
VRM I 1001 / 1301

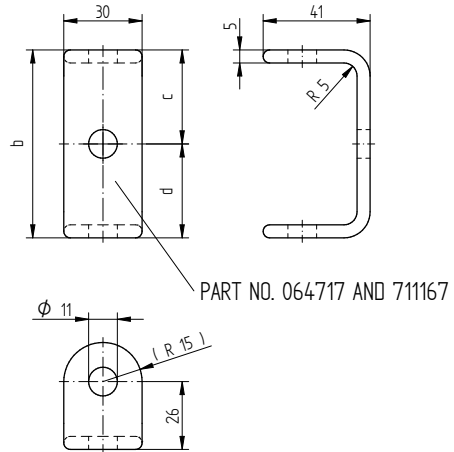

ARRANGEMENT OF CONTACT (see 890477:1)	PART NO.	DIMENSION b	DIMENSION c	DIMENSION d
A WITHOUT CONNECTING LEAD	064717	97	48,5	48,5
A WITH CONNECTING LEAD	711167	91	48,5	42,5

INSTALLATION OF PARALLEL BRIDGES FOR ARRANGEMENT OF CONTACT A WITHOUT AND WITH CONNECTING LEAD FOR 3W CONNECTION

VRS I 1001
VRM I 1001

WITHOUT
CONNECTING LEAD

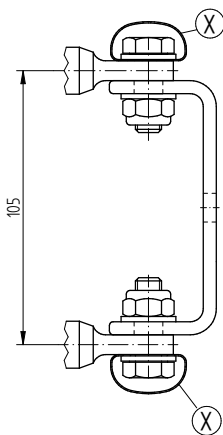

WITH CONNECTING LEAD

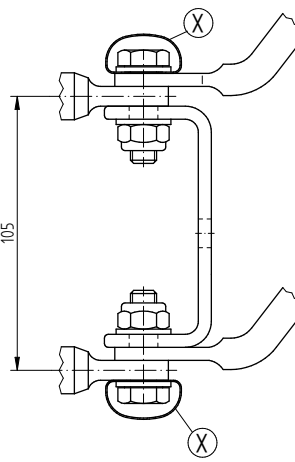

VRS I 1301
VRM I 1301

WITHOUT
CONNECTING LEAD

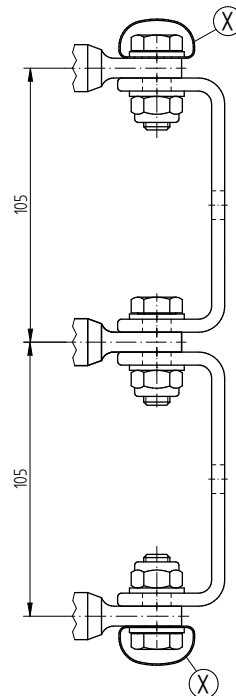

WITH CONNECTING LEAD

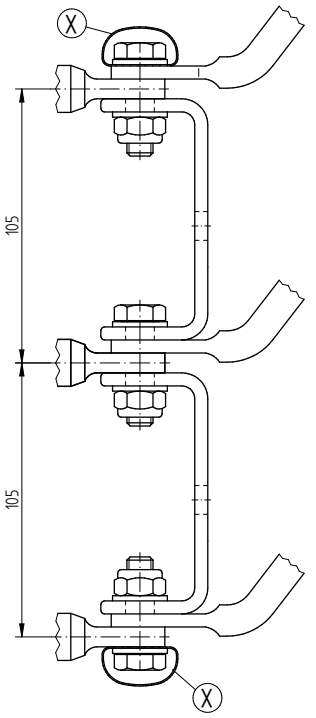

(X) ONLY FOR SELECTOR SIZE D AND DE

PLEASE NOTE: PARALLEL BRIDGES ARE NOT INCLUDED IN THE STANDARD DELIVERY.

DATE	NAME	DOCUMENT NO.
19.04.2018	RAEDLINGER	SED 6014:108 001 00
25.04.2018	HAUER	CHANGE NO.
25.04.2018	PRODASTSCHUK	1087395
		SCALE 1:1

DIMENSION
IN mm
EXCEPT AS
NOTED



Laststufenschalter VACUTAP® VR
 VRS/VRM I 1001/1301 – SELECTOR SIZE B/C/D/DE
 BRIDGES FOR PARALLEL CONNECTION OF SELECTOR CONN. CONTACT

SERIAL NUMBER

MATERIAL NUMBER 101170140E
 SHEET 1/1

© MASCHINENFABRIK REINHAUSEN GMBH 2017
 THE REPRODUCTION, DISTRIBUTION AND UTILIZATION OF THIS DOCUMENT AS WELL AS THE COMMUNICATION OF ITS CONTENTS TO OTHERS WITHOUT EXPRESS AUTHORIZATION IS PROHIBITED. OFFENDERS WILL BE HELD LIABLE FOR THE PAYMENT OF DAMAGES. ALL RIGHTS RESERVED IN THE EVENT OF THE GRANT OF A PATENT, UTILITY MODEL OR DESIGN.

SELECTOR SIZE E

THE SELECTION OF STRAIGHT CABLE SHOE OR ANGLE-SHAPED BY 90° MUST BE MADE BY THE TRANSFORMER MANUFACTURER FOR EACH CONNECTION CONTACT. (FOR MODEL WITH CHANGE-OVER SELECTOR: CONTACT "n MINUS 1" ALLOWS STRAIGHT CABLE SHOE ONLY, CONTACT "K" IS NOT FOR CUSTOMER'S USE.)

VARIANT 1

TAP SELECTOR AND CHANGE-OVER SELECTOR
CONNECTION CONTACT WITH STRAIGHT CABLE SHOE

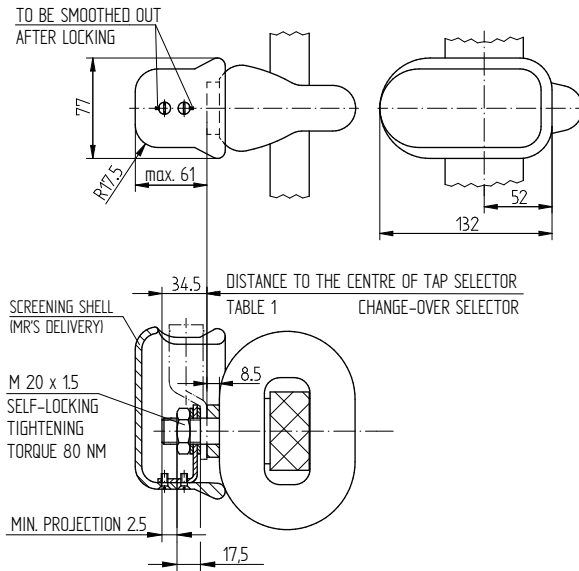

VARIANT 2

TAP SELECTOR AND CHANGE-OVER SELECTOR
CONNECTION CONTACT WITH 90° ANGLE CABLE SHOE

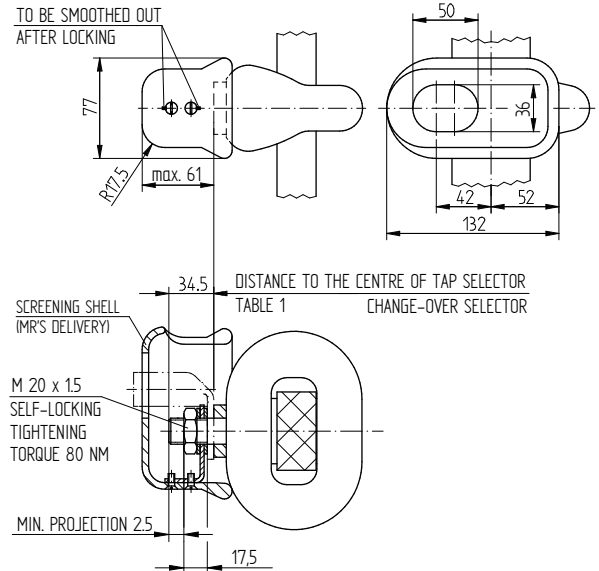
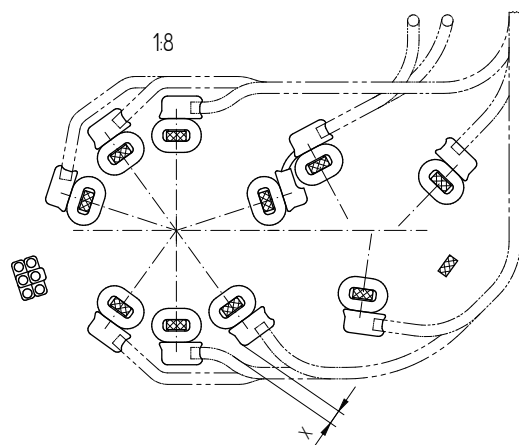

TABLE 1: DISTANCE TO THE CENTRE OF
TAP SELECTOR / CHANGE-OVER SELECTOR
(CONNECTING POINTS)

DESIGNATION OF CONNECTION CONTACTS	
TAP SELECTOR CONNECTION CONTACTS	352
CHANGE-OVER SELECTOR CONNECTION CONTACT "0"	176
CHANGE-OVER SELECTOR CONNECTION CONTACTS "+" AND "-"	383

THE ABOVE VARIANTS ARE APPLICABLE TO ONE SELECTOR CONNECTING LEAD FOR EACH CONNECTION CONTACT.
TWO SELECTOR CONNECTING LEADS FOR EACH CONNECTION CONTACTS AVAILABLE ON DEMAND.



X MIN. BETWEEN SCREENING SHELL AND ADJACENT LEAD = 25 mm.
(RATED LIGHTNING IMPULSE WITHSTAND VOLTAGE 300 kV 12/50 AND LEAD $\phi 18/\phi 28$)

SELECTOR SIZE C / D

TAP SELECTOR CONNECTION CONTACT AND
CHANGE-OVER SELECTOR CONNECTION CONTACT

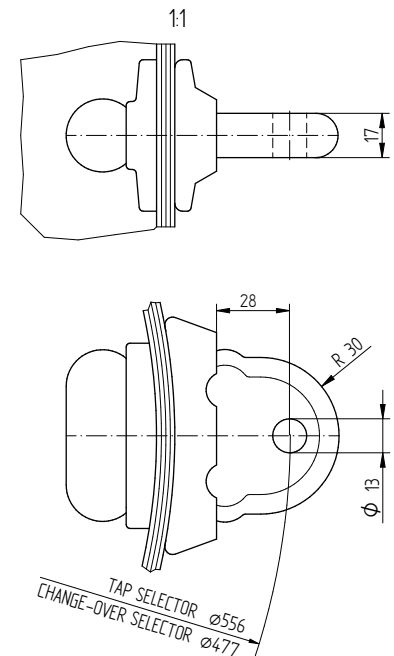

DATE	NAME	DOCUMENT NO.
15.05.2017	RAEDLINGER	SED 1055276 001 02
09.06.2017	SCHAFFBERGERT	CHANGE NO.
12.06.2017	PRODASTSCHUK	1081739
		SCALE 1:2

DIMENSION
IN mm
EXCEPT AS
NOTED



ON-LOAD TAP-CHANGER VACUTAP® VR
VRD/VRF/VRG - C/D/E TAP SELECTOR CONNECTION CONTACTS
AND CHANGE-OVER SELECTOR CONNECTION CONTACTS

SERIAL NUMBER

MATERIAL NUMBER 8999413E SHEET 1/1

4.6 전위연결 기구

© MASCHINENFABRIK REINHAUSEN GMBH 2016
 THE REPRODUCTION, DISTRIBUTION AND UTILIZATION OF THIS DOCUMENT AS WELL AS THE COMMUNICATION OF ITS CONTENTS TO OTHERS WITHOUT EXPRESS AUTHORIZATION IS PROHIBITED. OFFENDERS WILL BE HELD LIABLE FOR THE PAYMENT OF DAMAGES. ALL RIGHTS RESERVED IN THE EVENT OF THE GRANT OF A PATENT, UTILITY MODEL OR DESIGN.

WITH CHANGE-OVER SELECTOR (REVERSING / COARSE CHANGE-OVER SELECTOR) W, G

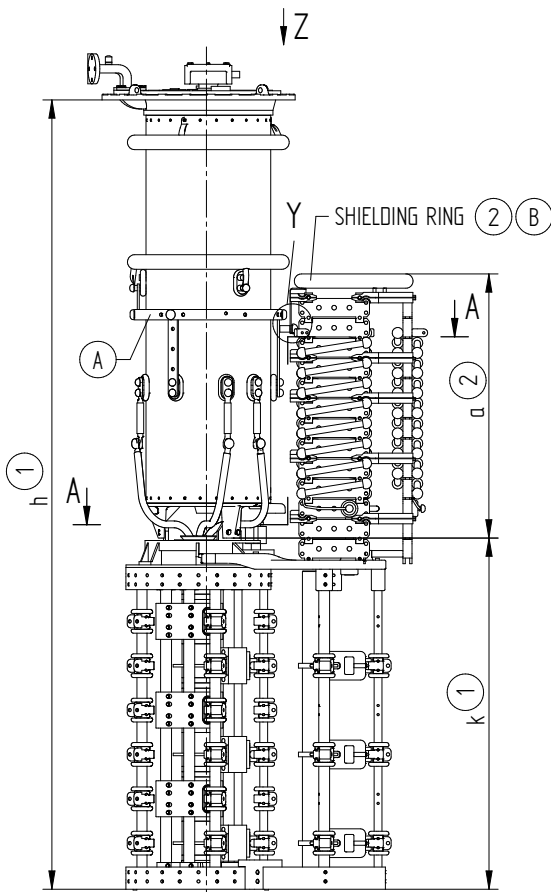

VRMIIIY VARIANT DISPLAYED

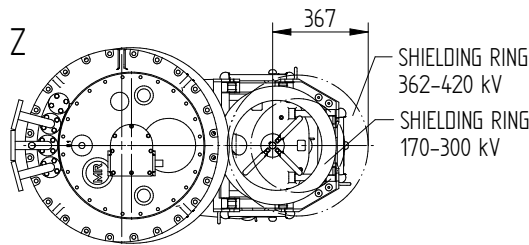

NUMBER AND POSITION OF CONNECTION CONTACT ②

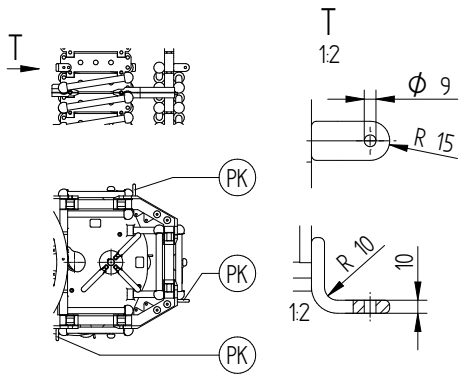

SCREW CONNECTION BETWEEN POTENTIAL CONNECTION UNIT AND TAKE-OFF RING ②

THE SCREW CONNECTION (IF AVAILABLE) IS MADE BY THE TRANSFORMER MANUFACTURER.

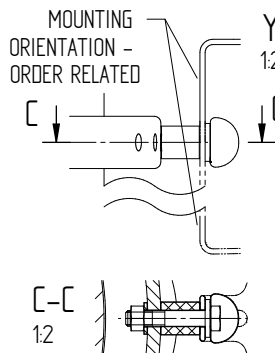

PRODUKT RANGE POTENTIAL CONNECTION UNIT WITH TIE-IN SWITCH WP/GP

ON-LOAD TAP-CHANGER VACUTAP®	NUMBER PHASES	CIRCUIT RESISTORS	Um [kV]	POTENTIAL NUMBER OF RESISTORS PER PHASES	MAX DIMENSIONS a [mm]
VRS	I	SERIES	72,5 ... 420	3 ... 22	740
		PARALLEL	72,5 ... 362	2x3 ... 2x17	894
			420	2x3 ... 2x14	817
	3-FOLD PARALLEL	72,5 ... 362	3x3 ... 3x12	894	
		420	3x3 ... 3x10	817	
	II	SERIES	72,5 ... 362	3 ... 14	894
PARALLEL			2x3 ... 2x7		
III	SERIES	72,5 ... 245	3 ... 12	859	
	PARALLEL		2x3 ... 2x5		
VRM VRH 650	I	SERIES	72,5 ... 420	3 ... 22	894
		PARALLEL	72,5 ... 362	2x3 ... 2x22	1048
			420	2x3 ... 2x20	971
	3-FOLD PARALLEL	72,5 ... 362	3x3 ... 3x16	1048	
		420	3x3 ... 3x14	971	
	II	SERIES	72,5 ... 362	3 ... 20	1048
		PARALLEL		2x3 ... 2x10	
	III	SERIES	72,5 ... 245	3 ... 16	1013
		PARALLEL		2x3 ... 2x7	
VRL VRH 1300 VRH 2622	I	SERIES	72,5 ... 420	3 ... 22	740
		PARALLEL	72,5 ... 362	2x3 ... 2x22	1048
			420	2x3 ... 2x20	971
	3-FOLD PARALLEL	72,5 ... 300	3x3 ... 3x18	975	
		362 ... 420	3x3 ... 3x16	1048	
	II	SERIES	72,5 ... 362	3 ... 22	1048
		PARALLEL		2x3 ... 2x10	
	III	SERIES	72,5 ... 245	3 ... 18	975
		PARALLEL		2x3 ... 2x8	

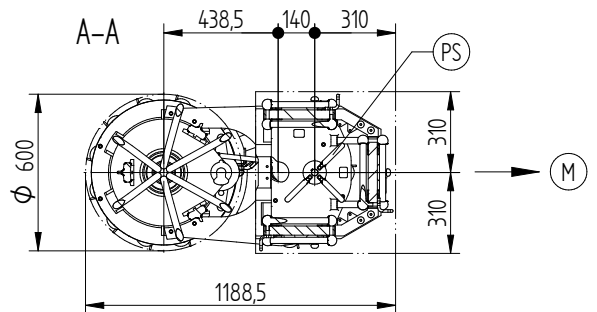

- Ⓜ - DRIVE SIDE OF SELECTOR
- Ⓐ - ON-LOAD TAP-CHANGER CURRENT TAKE-OFF TERMINAL
- Ⓑ - IS CONNECTED TO POTENTIAL OF Ⓐ
- ⓅⓀ - CONNECTION CONTACT
- ⓅⓈ - TIE-IN SWITCH
- ① - REFER TO DIMENSION DRAWING
- ② - IS ORDER RELATED, REFER TO ORDER RELATED DIMENSION DRAWING
- THE DETAILED CONNECTION DIAGRAM IS BINDING FOR THE DESIGNATION OF THE CONNECTION CONTACTS AND PHASES

DATE	NAME	DOCUMENT NO.
20.10.2016	CTETPRAKTIK2	SED 5159743 001 00
20.10.2016	HILTNER	CHANGE NO.
20.10.2016	PRODASTSCHUK	1077565
DFTR.		SCALE
CHKD.		1:1
STAND.		

DIMENSION IN mm EXCEPT AS NOTED



ON-LOAD TAP-CHANGER VACUTAP® VR
 VR S/M/L/H - POTENTIAL CONNECTION UNIT WP/GP - RC/RD/RDE
 DIMENSION DRAWING

SERIAL NUMBER

MATERIAL NUMBER 100180040E SHEET 1/1

© MASCHINENFABRIK REINHAUSEN GMBH 2016
 THE REPRODUCTION, DISTRIBUTION AND UTILIZATION OF THIS DOCUMENT AS WELL AS THE COMMUNICATION OF ITS CONTENTS TO OTHERS WITHOUT EXPRESS AUTHORIZATION IS PROHIBITED. OFFENDERS WILL BE HELD LIABLE FOR THE PAYMENT OF DAMAGES. ALL RIGHTS RESERVED IN THE EVENT OF THE GRANT OF A PATENT, UTILITY MODEL OR DESIGN.

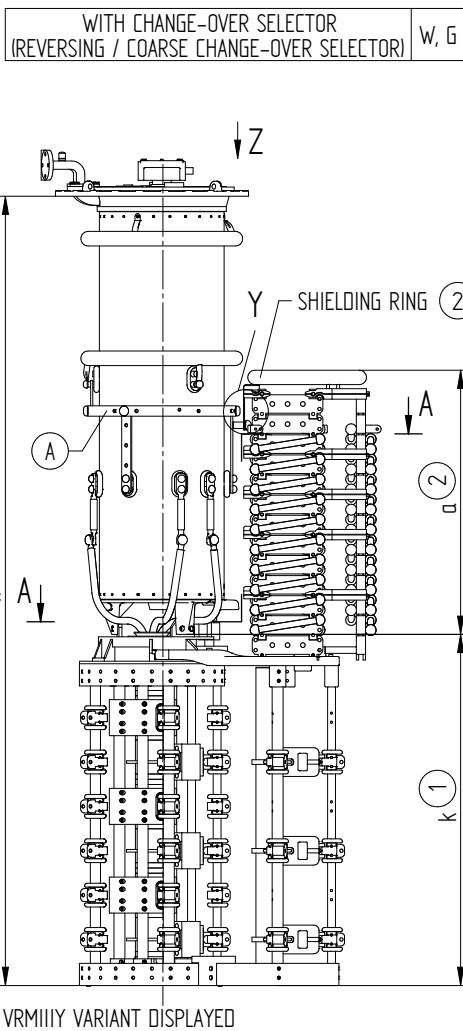

PRODUKT RANGE POTENTIAL CONNECTION UNIT WITHOUT TIE-IN SWITCH WR/GR						
ON-LOAD TAP-CHANGER VACUTAP®	NUMBER PHASES	CIRCUIT RESISTORS	Um [kV]	POTENTIAL NUMBER OF RESISTORS PER PHASES	MAX DIMENSIONS a [mm]	
VRS	I	SERIES	72,5 ... 420	3 ... 22	663	
		PARALLEL	72,5 ... 362	2x3 ... 2x22	894	
			420	2x3 ... 2x19	817	
	II	3-FOLD PARALLEL	72,5 ... 362	3x3 ... 3x16	894	
		PARALLEL	420	3x3 ... 3x14	817	
			SERIES	72,5 ... 362	3 ... 20	894
III	SERIES	72,5 ... 245	3 ... 16	859		
	PARALLEL		2x3 ... 2x7			
VRM VRH 650	I	SERIES	72,5 ... 420	3 ... 22	663	
		PARALLEL	72,5 ... 362	2x3 ... 2x22	894	
			420	3x3 ... 3x20	1048	
	II	SERIES	72,5 ... 362	3 ... 22	1048	
		PARALLEL		2x3 ... 2x13		
	III	SERIES	72,5 ... 245	3 ... 20	1013	
		PARALLEL		2x3 ... 2x9		
	VRL VRH 1300 VRH 2622	I	SERIES	72,5 ... 420	3 ... 22	663
			PARALLEL	72,5 ... 300	2x3 ... 2x22	971
362 ... 420				3x3 ... 3x22	975	
II		SERIES	72,5 ... 362	3 ... 22	1048	
		PARALLEL		2x3 ... 2x13		
III		SERIES	72,5 ... 245	3 ... 22	975	
		PARALLEL		2x3 ... 2x10		

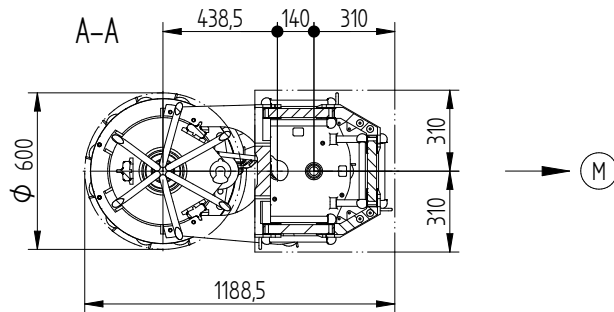
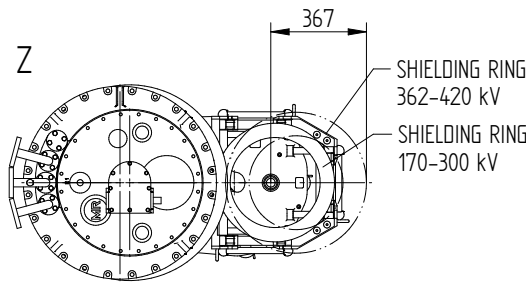

NUMBER AND POSITION OF CONNECTION CONTACT (2)

SCREW CONNECTION BETWEEN POTENTIAL CONNECTION UNIT AND TAKE-OFF RING (2)

THE SCREW CONNECTION (IF AVAILABLE) IS MADE BY THE TRANSFORMER MANUFACTURER.

- (M) - DRIVE SIDE OF SELECTOR
 - (A) - ON-LOAD TAP-CHANGER CURRENT TAKE-OFF TERMINAL
 - (B) - IS CONNECTED TO POTENTIAL OF (A)
 - (PK) - CONNECTION CONTACT
 - (1) - REFER TO DIMENSION DRAWING
 - (2) - IS ORDER RELATED, REFER TO ORDER RELATED DIMENSION DRAWING
- THE DETAILED CONNECTION DIAGRAM IS BINDING FOR THE DESIGNATION OF THE CONNECTION CONTACTS AND PHASES

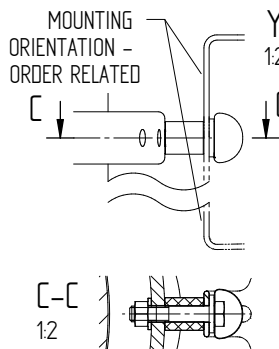
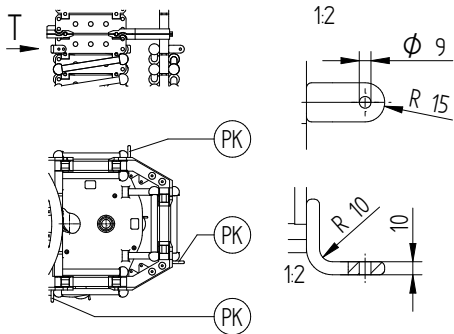

DATE	NAME	DOCUMENT NO.
18.10.2016	CTETPRAKTIK2	SED 5'59886 001 00
20.10.2016	HILTNER	CHANGE NO.
20.10.2016	PRODASTSCHUK	1077565
		SCALE 1:10

DIMENSION IN mm EXCEPT AS NOTED



ON-LOAD TAP-CHANGER VACUTAP® VR
 VR S/M/L/H - POTENTIAL CONNECTION UNIT WR/GR - RC/RD/RDE
 DIMENSION DRAWING

SERIAL NUMBER

MATERIAL NUMBER	SHEET
100180080E	1/1

© MASCHINENFABRIK REINHAUSEN GMBH 2016
 THE REPRODUCTION, DISTRIBUTION AND UTILIZATION OF THIS DOCUMENT AS WELL AS THE COMMUNICATION OF ITS CONTENTS TO OTHERS WITHOUT EXPRESS AUTHORIZATION IS PROHIBITED. OFFENDERS WILL BE HELD LIABLE FOR THE PAYMENT OF DAMAGES. ALL RIGHTS RESERVED IN THE EVENT OF THE GRANT OF A PATENT, UTILITY MODEL OR DESIGN.

WITH CHANGE-OVER SELECTOR
(REVERSING / COARSE CHANGE-OVER SELECTOR) W, G

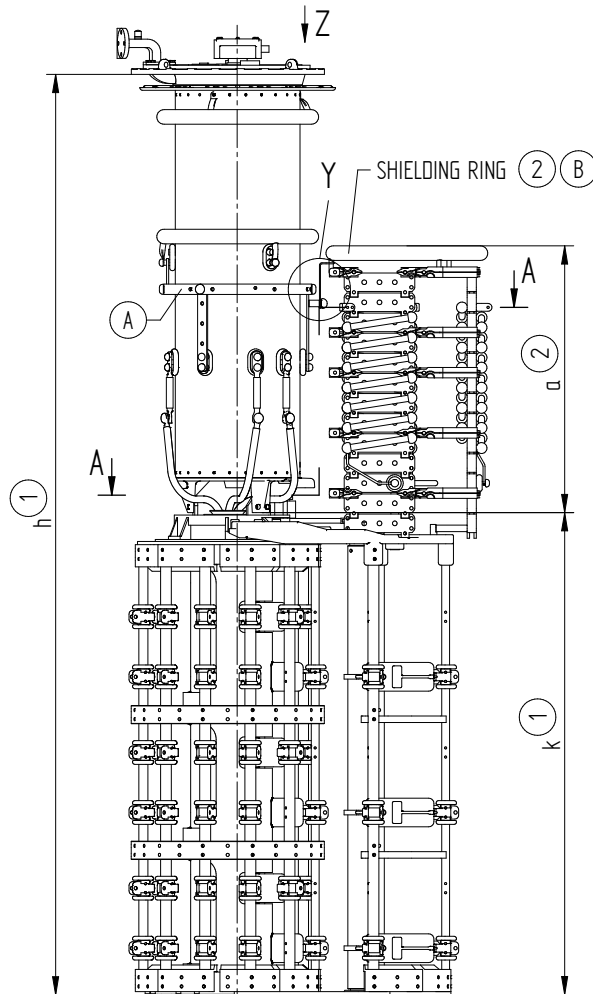

VRMIIII VARIANT DISPLAYED

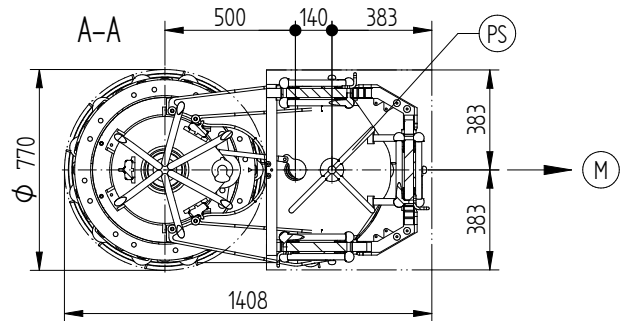
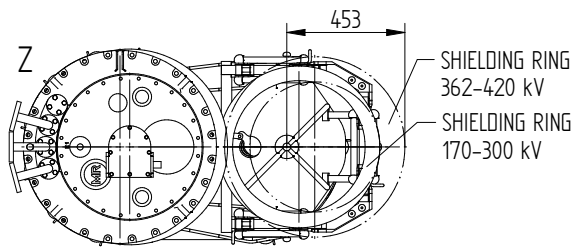

NUMBER AND POSITION OF CONNECTION CONTACT (2)

SCREW CONNECTION BETWEEN
POTENTIAL CONNECTION UNIT AND
TAKE-OFF RING (2)

THE SCREW CONNECTION (IF AVAILABLE) IS
MADE BY THE TRANSFORMER MANUFACTURER.

- (M) - DRIVE SIDE OF SELECTOR
 - (A) - ON-LOAD TAP-CHANGER CURRENT TAKE-OFF TERMINAL
 - (B) - IS CONNECTED TO POTENTIAL OF (A)
 - (PK) - CONNECTION CONTACT
 - (PS) - TIE-IN SWITCH
 - (1) - REFER TO DIMENSION DRAWING
 - (2) - IS ORDER RELATED, REFER TO ORDER RELATED DIMENSION DRAWING
- THE DETAILED CONNECTION DIAGRAM IS BINDING FOR THE DESIGNATION OF THE CONNECTION CONTACTS AND PHASES

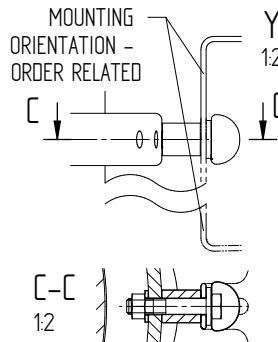
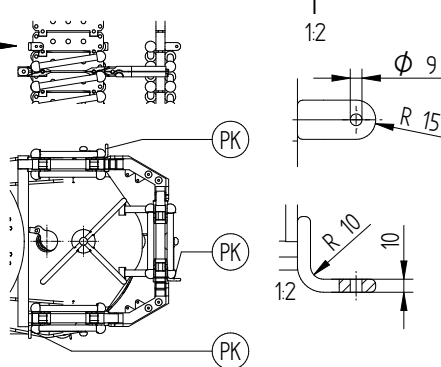

DOCUMENT NO.	DATE	NAME	CHANGE NO.	SCALE
SED 5160053 001 00	18.10.2016	CTETPRAKTIK2	1077565	1:1
HILTNER	20.10.2016	HILTNER		
PRODASTSCHUK	20.10.2016	PRODASTSCHUK		

DIMENSION
IN mm
EXCEPT AS
NOTED



ON-LOAD TAP-CHANGER VACUTAP® VR
VR S/M/L/H/X - POTENTIAL CONNECTION UNIT WP/GP - RE/RF/RES
DIMENSION DRAWING

SERIAL NUMBER

MATERIAL NUMBER 100180110E SHEET 1/2

© MASCHINENFABRIK REINHAUSEN GMBH 2016
 THE REPRODUCTION, DISTRIBUTION AND UTILIZATION OF THIS DOCUMENT AS WELL AS THE COMMUNICATION OF ITS CONTENTS TO OTHERS WITHOUT EXPRESS AUTHORIZATION IS PROHIBITED. OFFENDERS WILL BE HELD LIABLE FOR THE PAYMENT OF DAMAGES. ALL RIGHTS RESERVED IN THE EVENT OF THE GRANT OF A PATENT, UTILITY MODEL OR DESIGN.

DATE	NAME	DOCUMENT NO.
DFTR. 18.10.2016	CTETPRAKTIK2	SED 5160053 001 00
CHKD. 20.10.2016	HILTNER	CHANGE NO.
STAND. 20.10.2016	PRODASTSCHUK	1077565
		SCALE 1:1

PRODUCT RANGE POTENTIAL CONNECTION UNIT WITH TIE-IN SWITCH WP/GP									
ON-LOAD TAP-CHANGER VACUTAP®	NUMBER PHASES	SELECTOR DESIGN	CIRCUIT RESISTORS	Um [kV]	POTENTIAL NUMBER OF RESISTORS PER PHASES	MAX. DIMENSIONS a [mm]	SEPARATE TRANSPORT POTENTIAL CONNECTION UNIT		
VRS	I	RE, RF	SERIES	72,5 ... 420	3 ... 22	832	NO		
			PARALLEL	72,5 ... 362	2x3 ... 2x14	909			
				420	2x3 ... 2x10	832			
			3-FOLD PARALLEL	72,5 ... 362	3x3 ... 3x10	909			
	420			3x3 ... 3x8	832				
	II		SERIES	72,5 ... 362	3 ... 12	909			
			PARALLEL		2x3 ... 2x5				
	III		RE	SERIES	72,5 ... 123	3 ... 10		869	YES
		170 ... 245			3 ... 8	667			
		72,5 ... 245			3 ... 8	667	NO		
					9 ... 10	869	YES		
		RF	PARALLEL		72,5 ... 123	2x3 ... 2x4	744	NO	
					170 ... 245	2x3	667		
						2x4	869		YES
					72,5 ... 245	2x3	667		NO
	2x4	869		YES					
VRM VRH 650	I	RE, RF		SERIES	72,5 ... 420	3 ... 22	832	NO	
				PARALLEL	72,5 ... 362	2x3 ... 2x20	1063		
					420	2x3 ... 2x16	986		
			3-FOLD PARALLEL	72,5 ... 362	3x3 ... 3x14	1063			
	420			3x3 ... 3x12	986				
	II		SERIES	72,5 ... 362	3 ... 18	1063			
			PARALLEL		2x3 ... 2x9				
	III		RE	SERIES	72,5 ... 245	3 ... 12	821		YES
		13 ... 14				1023	NO		
		3 ... 4				496	NO		
		RF	5 ... 14			1023	YES		
			RE			PARALLEL	2x3 ... 2x5	821	NO
2x6							1023	YES	
2x3 ... 2x6									
VRL VRH 1300 VRH 2622	I	RE, RF	SERIES	72,5 ... 420	3 ... 22	832	NO		
			PARALLEL		2x3 ... 2x22	1140			
					72,5 ... 362	3x3 ... 3x18		1217	
			3-FOLD PARALLEL		420	3x3 ... 3x16		1140	
	II			SERIES	72,5 ... 362	3 ... 22		1217	
			PARALLEL		2x3 ... 2x11				
	III		RE	SERIES	72,5 ... 245	3 ... 8		667	NO
						9 ... 18		1177	YES
		3 ... 4				496	NO		
		RF	5 ... 18			1177	YES		
			RE			PARALLEL	2x3	667	NO
							2x4 ... 2x8	1177	YES
2x3 ... 2x8									
VRX	I	RES	SERIES	72,5 ... 300	3 ... 12	821	NO		
					13 ... 14	1023	YES		
				362	3 ... 8	832	NO		
					9 ... 14	1063	YES		
					2x3 ... 2x5	821	NO		
			PARALLEL	72,5 ... 300	2x6	1023	YES		
					2x3	832	NO		
				362	2x4 ... 2x6	1063	YES		

DIMENSION IN mm EXCEPT AS NOTED



ON-LOAD TAP-CHANGER VACUTAP® VR
 VR S/M/L/H/X - POTENTIAL CONNECTION UNIT WP/GP - RE/RF/RES
 DIMENSION DRAWING

SERIAL NUMBER

MATERIAL NUMBER 100180110E

SHEET 2/2

© MASCHINENFABRIK REINHAUSEN GMBH 2016
 THE REPRODUCTION, DISTRIBUTION AND UTILIZATION OF THIS DOCUMENT AS WELL AS THE COMMUNICATION OF ITS CONTENTS TO OTHERS WITHOUT EXPRESS AUTHORIZATION IS PROHIBITED. OFFENDERS WILL BE HELD LIABLE FOR THE PAYMENT OF DAMAGES. ALL RIGHTS RESERVED IN THE EVENT OF THE GRANT OF A PATENT, UTILITY MODEL OR DESIGN.

WITH CHANGE-OVER SELECTOR
 (REVERSING / COARSE CHANGE-OVER SELECTOR) W, G

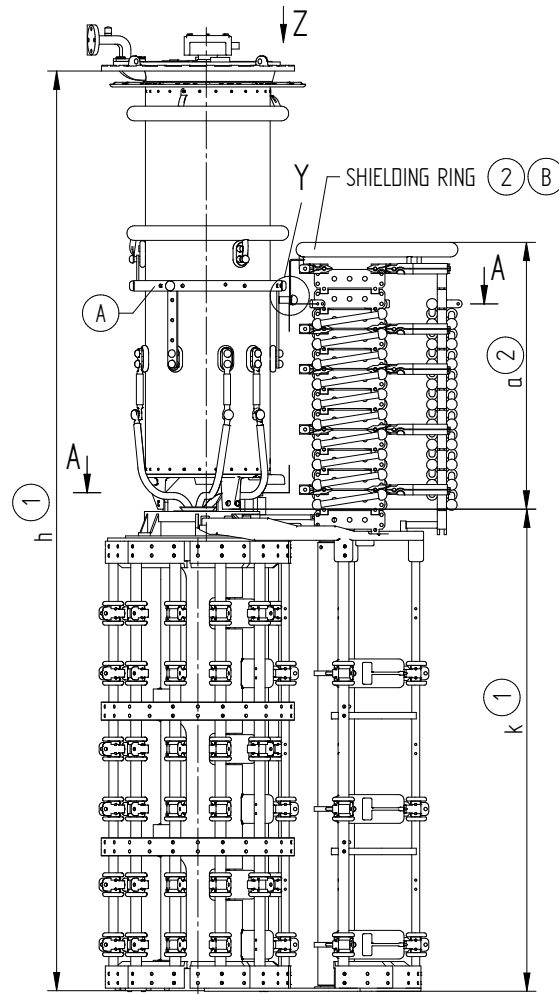

VRMIIII VARIANT DISPLAYED

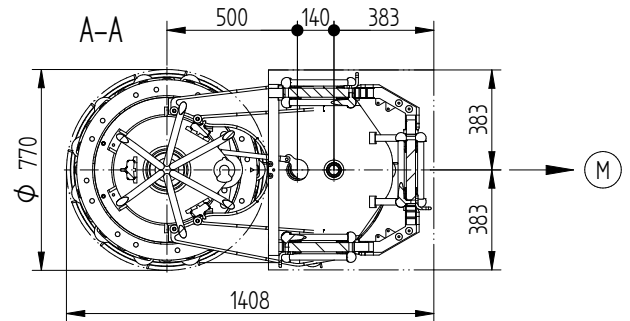
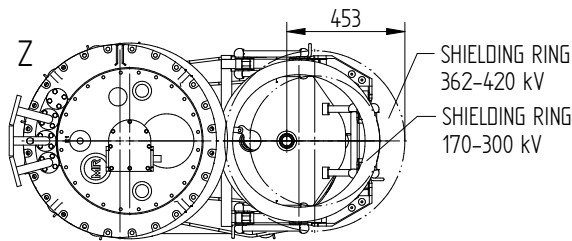

NUMBER AND POSITION OF CONNECTION CONTACT (2)

SCREW CONNECTION BETWEEN
 POTENTIAL CONNECTION UNIT AND
 TAKE-OFF RING (2)

THE SCREW CONNECTION (IF AVAILABLE) IS
 MADE BY THE TRANSFORMER MANUFACTURER.

- (M) - DRIVE SIDE OF SELECTOR
- (A) - ON-LOAD TAP-CHANGER CURRENT TAKE-OFF TERMINAL
- (B) - IS CONNECTED TO POTENTIAL OF (A)
- (PK) - CONNECTION CONTACT
- (1) - REFER TO DIMENSION DRAWING
- (2) - IS ORDER RELATED, REFER TO ORDER RELATED DIMENSION DRAWING
- THE DETAILED CONNECTION DIAGRAM IS BINDING FOR THE DESIGNATION OF THE CONNECTION CONTACTS AND PHASES

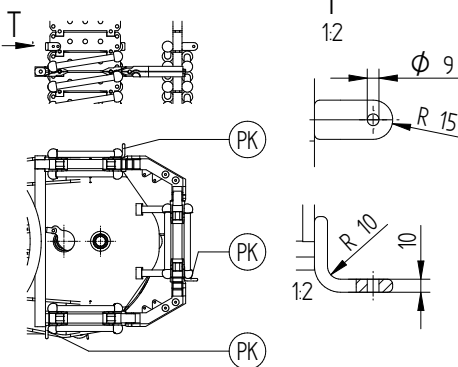

DOCUMENT NO.	SED 5160136 001 00
NAME	CTETPRAKTIK2
DATE	18.10.2016
CHKD.	20.10.2016
SCALE	1:10
CHANGE NO.	1077565
PRODASTSCHUK	
STAND.	20.10.2016

DIMENSION
 IN mm
 EXCEPT AS
 NOTED



ON-LOAD TAP-CHANGER VACUTAP® VR
 VR S/M/L/H - POTENTIAL CONNECTION UNIT WR/GR - RE/RF
 DIMENSION DRAWING

SERIAL NUMBER

MATERIAL NUMBER 100180130E SHEET 1/2

© MASCHINENFABRIK REINHAUSEN GMBH 2016
 THE REPRODUCTION, DISTRIBUTION AND UTILIZATION OF THIS DOCUMENT AS WELL AS THE COMMUNICATION OF ITS CONTENTS TO OTHERS WITHOUT EXPRESS AUTHORIZATION IS PROHIBITED. OFFENDERS WILL BE HELD LIABLE FOR THE PAYMENT OF DAMAGES. ALL RIGHTS RESERVED IN THE EVENT OF THE GRANT OF A PATENT, UTILITY MODEL OR DESIGN.

DFTR.	DATE	NAME	DOCUMENT NO.
CHKD.	18.10.2016	CTETPRAKTIK2	SED 5160136 001 00
STAND.	20.10.2016	HILTNER	SCALE
	20.10.2016	PRODASTSCHUK	1:10
			CHANGE NO.
			1077565

PRODUCT RANGE POTENTIAL CONNECTION UNIT WITHOUT TIE-IN SWITCH WR/GR											
ON-LOAD TAP-CHANGER VACUTAP®	NUMBER PHASES	SELECTOR DESIGN	CIRCUIT RESISTORS	Um [kV]	POTENTIAL NUMBER OF RESISTORS PER PHASES	MAX. DIMENSIONS α [mm]	SEPARATE TRANSPORT POTENTIAL CONNECTION UNIT				
VRS	I	RE, RF	SERIES	72,5 ... 420	3 ... 22	678	NO				
			PARALLEL		72,5 ... 362	2x3 ... 2x20		909			
			3-FOLD PARALLEL	420	2x3 ... 2x18	832					
				72,5 ... 362	3x3 ... 3x16	909					
			PARALLEL	420	3x3 ... 3x14	832					
				II	RE, RF	SERIES		72,5 ... 362	3 ... 20	909	
	PARALLEL	2x3 ... 2x10									
	III	RE	SERIES	72,5 ... 123	3 ... 16	744		YES			
				170 ... 245	3 ... 14	667					
				72,5 ... 245	15 ... 16	869					
					3 ... 14	667			NO		
				RF	15 ... 16	869			YES		
					RE	PARALLEL	72,5 ... 123		2x3 ... 2x7	744	NO
		170 ... 245	2x3 ... 2x6	667							
			2x7	869							
		72,5 ... 245	2x3 ... 2x6	667			NO				
			2x7	869			YES				
		VRM VRH 650	I	RE, RF			SERIES	72,5 ... 420	3 ... 22	678	
PARALLEL					72,5 ... 362	2x3 ... 2x22	968				
3-FOLD PARALLEL	420				3x3 ... 3x20	1063					
	72,5 ... 362				3x3 ... 3x18	986					
II	RE, RF				SERIES	72,5 ... 362	3 ... 22	1063			
					PARALLEL		2x3 ... 2x13				
III	RE		SERIES	72,5 ... 245	3 ... 18	821	YES				
					19 ... 20	1023					
					3 ... 10	496		NO			
					11 ... 20	1023		YES			
					2x3 ... 2x8	821		NO			
					2x9	1023		YES			
	RF		PARALLEL	2x3 ... 2x4	496	NO					
				2x5 ... 2x9	1023	YES					
				VRL VRH 1300 VRH 2622	I	RE, RF	72,5 ... 420	SERIES	3 ... 22	678	NO
								PARALLEL	2x3 ... 2x22	968	
								3-FOLD PARALLEL	3x3 ... 3x22	1140	
									72,5 ... 362	3 ... 22	
II	RE, RF	SERIES	72,5 ... 362					2x3 ... 2x16	1217		
		PARALLEL						3 ... 14	667		
III	RE	SERIES	72,5 ... 245	15 ... 22	975	YES					
				3 ... 10	496		NO				
				11 ... 22	975		YES				
				2x3 ... 2x6	667		NO				
				2x7 ... 2x11	1177		YES				
				2x3 ... 2x4	496		NO				
	RF	PARALLEL	2x5 ... 2x11	1177	YES						

DIMENSION IN mm EXCEPT AS NOTED



ON-LOAD TAP-CHANGER VACUTAP® VR
 VR S/M/L/H - POTENTIAL CONNECTION UNIT WR/GR - RE/RF
 DIMENSION DRAWING

SERIAL NUMBER

MATERIAL NUMBER 100180130E SHEET 2/2

MASCHINENFABRIK REINHAUSEN GMBH COPYRIGHT RESERVED
 THE REPRODUCTION, DISTRIBUTION AND UTILIZATION OF THIS DOCUMENT AS WELL AS THE COMMUNICATION OF ITS CONTENTS TO OTHERS WITHOUT EXPRESS AUTHORIZATION IS PROHIBITED. OFFENDERS WILL BE HELD LIABLE FOR THE PAYMENT OF DAMAGES. ALL RIGHTS RESERVED IN THE EVENT OF THE GRANT OF A PATENT, UTILITY MODEL OR DESIGN.

WITH CHANGE-OVER SELECTOR (REVERSING / COARSE CHANGE-OVER SELECTOR) W, G

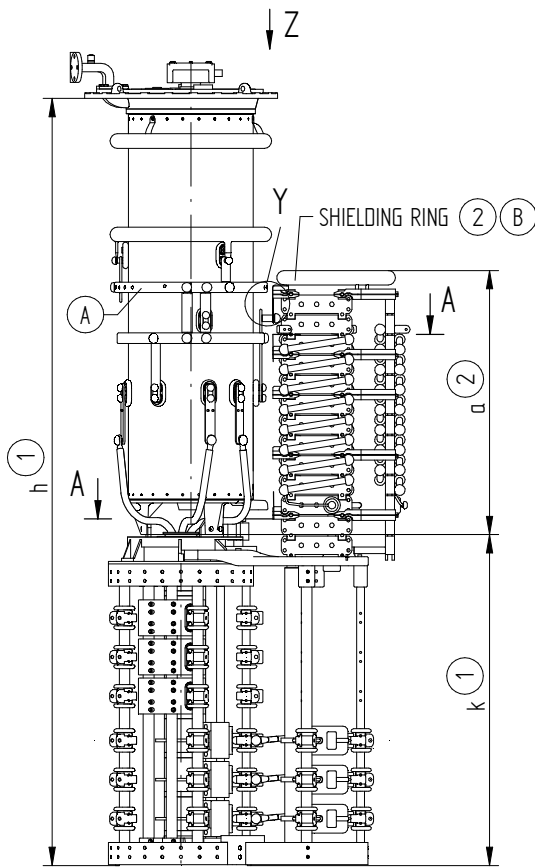

VRL I 2601 VARIANT DISPLAYED

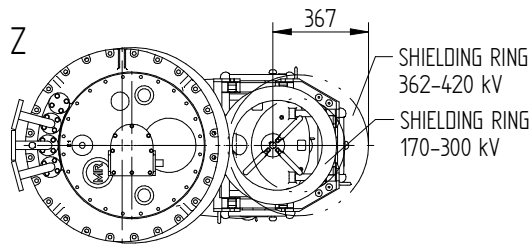

PRODUKT RANGE POTENTIAL CONNECTION UNIT WITH TIE-IN SWITCH WP/GP					
ON-LOAD TAP-CHANGER VACUTAP®	NUMBER PHASES	CIRCUIT RESISTORS	Um [kV]	POTENTIAL NUMBER OF RESISTORS PER PHASES	MAX DIMENSIONS a [mm]
VRL I 1801 VRL I 2001 VRL I 2401 VRL I 2601 VRL I 3001 VRL I 3201	1	SERIES	72,5 ... 420	3 ... 22	894
		PARALLEL	72,5 ... 362	2x3 ... 2x22	1048
			420	2x3 ... 2x20	971
		3-FOLD PARALLEL	72,5 ... 362	3x3 ... 3x16	1048
			420	3x3 ... 3x14	971

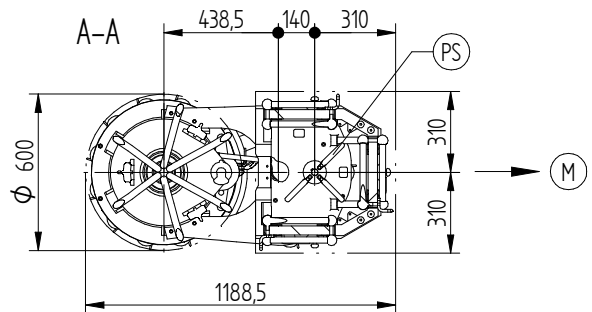

NUMBER AND POSITION OF CONNECTION CONTACT (2)

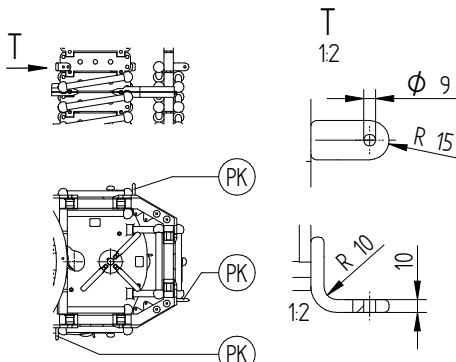

SCREW CONNECTION BETWEEN POTENTIAL CONNECTION UNIT AND CONNECTOR (2)

THE SCREW CONNECTION (IF AVAILABLE) IS MADE BY THE TRANSFORMER MANUFACTURER.

MOUNTING ORIENTATION - ORDER RELATED

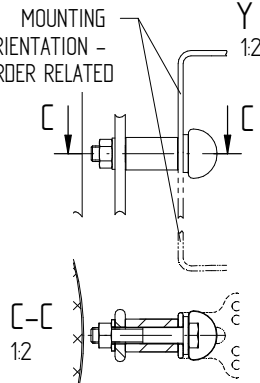

- (M) - DRIVE SIDE OF SELECTOR
- (A) - ON-LOAD TAP-CHANGER CURRENT TAKE-OFF TERMINAL
- (B) - IS CONNECTED TO POTENTIAL OF (A)
- (PK) - CONNECTION CONTACT
- (PS) - TIE-IN SWITCH
- (1) - REFER TO DIMENSION DRAWING
- (2) - IS ORDER RELATED, REFER TO ORDER RELATED DIMENSION DRAWING
- THE DETAILED CONNECTION DIAGRAM IS BINDING FOR THE DESIGNATION OF THE CONNECTION CONTACTS AND PHASES

DATE	NAME	DOCUMENT NO.
13.12.2021	RAEDLINGER	SED 84954/8 001 00
CHKO.	MENZELS	SCALE
14.12.2021	WANNINGER	1:10
STAND.		CHANGE NO.
		1103709

DIMENSION IN mm EXCEPT AS NOTED



ON-LOAD TAP-CHANGER VACUTAP® VR®
 VRL I 1801 ... 3201 - POTENTIAL CONNECTION UNIT WP/GP - RC/RD/RDE
 DIMENSION DRAWING

SERIAL NUMBER

MATERIAL NUMBER 101667670E SHEET 1/1

MASCHINENFABRIK REINHAUSEN GMBH COPYRIGHT RESERVED
 THE REPRODUCTION, DISTRIBUTION AND UTILIZATION OF THIS DOCUMENT AS WELL AS THE COMMUNICATION OF ITS CONTENTS TO OTHERS WITHOUT EXPRESS AUTHORIZATION IS PROHIBITED. OFFENDERS WILL BE HELD LIABLE FOR THE PAYMENT OF DAMAGES. ALL RIGHTS RESERVED IN THE EVENT OF THE GRANT OF A PATENT, UTILITY MODEL OR DESIGN.

WITH CHANGE-OVER SELECTOR (REVERSING / COARSE CHANGE-OVER SELECTOR) W, G

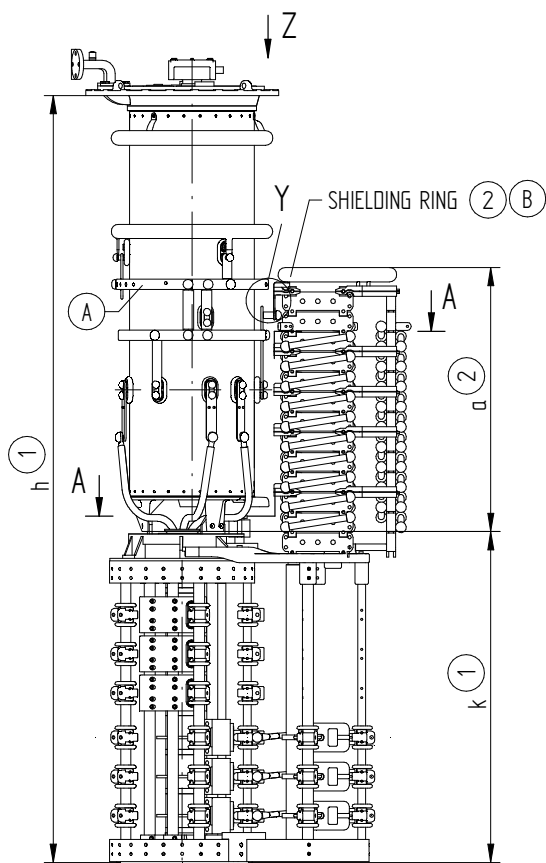

VRL I 2601 VARIANT DISPLAYED

ON-LOAD TAP-CHANGER VACUTAP®	NUMBER PHASES	CIRCUIT RESISTORS	Um [kV]	POTENTIAL NUMBER OF RESISTORS PER PHASES	MAX DIMENSIONS a [mm]
VRL I 1801	I	SERIES	72,5 ... 420	3 ... 22	663
VRL I 2001		PARALLEL		2x3 ... 2x22	894
VRL I 2401		3-FOLD PARALLEL	72,5 ... 362	3x3 ... 3x20	1048
VRL I 2601				3x3 ... 3x18	971
VRL I 3001			420		
VRL I 3201					

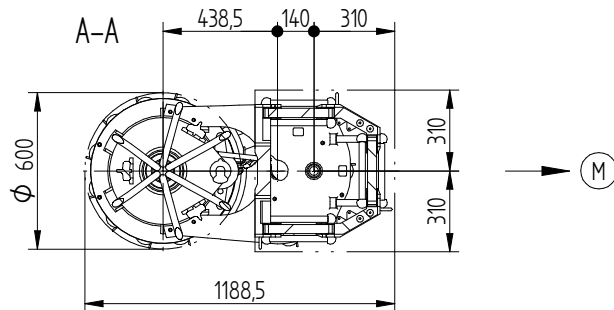
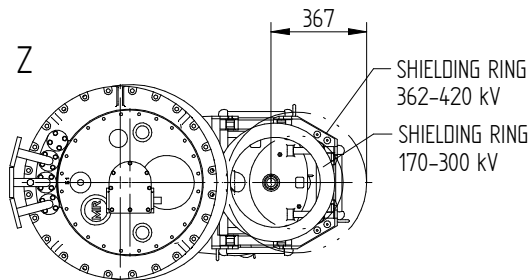

NUMBER AND POSITION OF CONNECTION CONTACT (2)

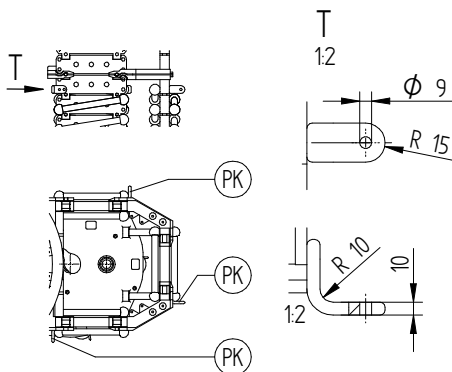

SCREW CONNECTION BETWEEN POTENTIAL CONNECTION UNIT AND CONNECTOR (2)

THE SCREW CONNECTION (IF AVAILABLE) IS MADE BY THE TRANSFORMER MANUFACTURER.

MOUNTING ORIENTATION - ORDER RELATED

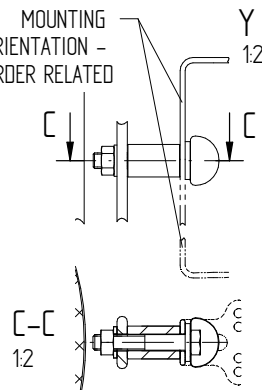

- (M) - DRIVE SIDE OF SELECTOR
 - (A) - ON-LOAD TAP-CHANGER CURRENT TAKE-OFF TERMINAL
 - (B) - IS CONNECTED TO POTENTIAL OF (A)
 - (PK) - CONNECTION CONTACT
 - (1) - REFER TO DIMENSION DRAWING
 - (2) - IS ORDER RELATED, REFER TO ORDER RELATED DIMENSION DRAWING
- THE DETAILED CONNECTION DIAGRAM IS BINDING FOR THE DESIGNATION OF THE CONNECTION CONTACTS AND PHASES

DATE	NAME	DOCUMENT NO.
13.12.2021	RAEDLINGER	SED 8483828 001 00
13.12.2021	MENZELS	SCALE
14.12.2021	WANNINGER	1:10
		CHANGE NO.
		1103709

DIMENSION IN mm EXCEPT AS NOTED



ON-LOAD TAP-CHANGER VACUTAP® VR®
 VRL I 1801 ... 3201 - POTENTIAL CONNECTION UNIT WR/GR - RC/RD/RDE
 DIMENSION DRAWING

SERIAL NUMBER

MATERIAL NUMBER 101667660E SHEET 1/1

MASCHINENFABRIK REINHAUSEN GMBH COPYRIGHT RESERVED
 THE REPRODUCTION, DISTRIBUTION AND UTILIZATION OF THIS DOCUMENT AS WELL AS THE COMMUNICATION OF ITS CONTENTS TO OTHERS WITHOUT EXPRESS AUTHORIZATION IS PROHIBITED. OFFENDERS WILL BE HELD LIABLE FOR THE PAYMENT OF DAMAGES. ALL RIGHTS RESERVED IN THE EVENT OF THE GRANT OF A PATENT, UTILITY MODEL OR DESIGN.

WITH CHANGE-OVER SELECTOR
(REVERSING / COARSE CHANGE-OVER SELECTOR) W, G

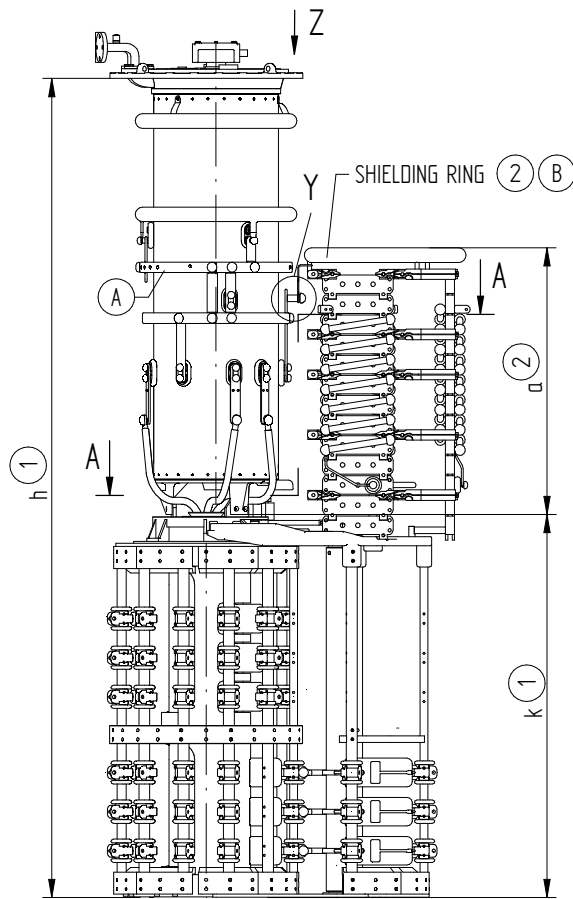

VRL I 2601 VARIANT DISPLAYED

PRODUCT RANGE POTENTIAL CONNECTION UNIT WITH TIE-IN SWITCH WP/GP					
ON-LOAD TAP-CHANGER VACUTAP®	NUMBER PHASES	CIRCUIT RESISTORS	Um [kV]	POTENTIAL NUMBER OF RESISTORS PER PHASES	MAX. DIMENSIONS a [mm]
VRL I 1801 VRL I 2001 VRL I 2401 VRL I 2601 VRL I 3001 VRL I 3201	I	SERIES	725 ... 420	3 ... 22	832
		PARALLEL	725 ... 362	2x3 ... 2x20	1063
			420	2x3 ... 2x16	986
		3-FOLD PARALLEL	725 ... 362	3x3 ... 3x14	1063
420	3x3 ... 3x12		986		

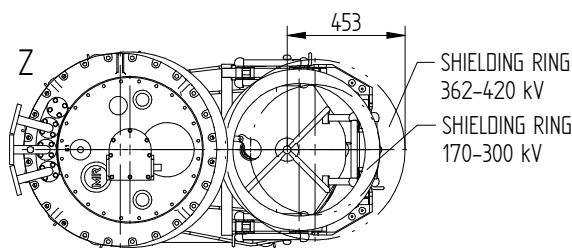

SHIELDING RING 362-420 kV
SHIELDING RING 170-300 kV

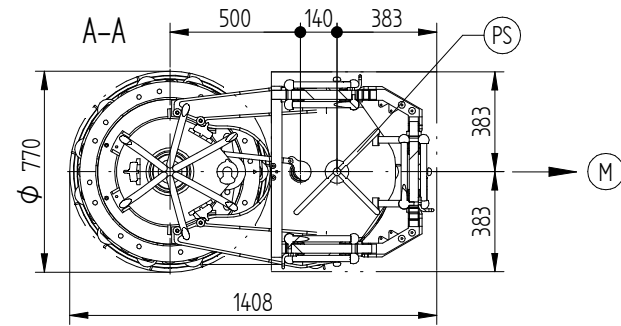

NUMBER AND POSITION OF CONNECTION CONTACT (2)

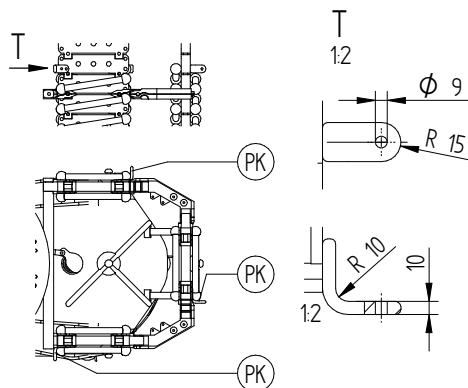

SCREW CONNECTION BETWEEN POTENTIAL CONNECTION UNIT AND CONNECTOR (2)

THE SCREW CONNECTION (IF AVAILABLE) IS MADE BY THE TRANSFORMER MANUFACTURER.

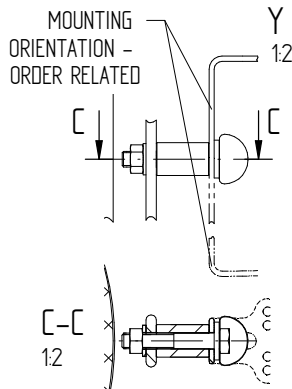

- (M) - DRIVE SIDE OF SELECTOR
 - (A) - ON-LOAD TAP-CHANGER CURRENT TAKE-OFF TERMINAL
 - (B) - IS CONNECTED TO POTENTIAL OF (A)
 - (PK) - CONNECTION CONTACT
 - (PS) - TIE-IN SWITCH
 - (1) - REFER TO DIMENSION DRAWING
 - (2) - IS ORDER RELATED, REFER TO ORDER RELATED DIMENSION DRAWING
- THE DETAILED CONNECTION DIAGRAM IS BINDING FOR THE DESIGNATION OF THE CONNECTION CONTACTS AND PHASES

DATE	NAME	DOCUMENT NO.
13.12.2021	RAEDLINGER	SED 8495707 001 00
13.12.2021	MENZELS	SCALE
14.12.2021	WANNINGER	1:10
CHKO.	CHANGE NO.	
STAND.		

DIMENSION IN mm EXCEPT AS NOTED



ON-LOAD TAP-CHANGER VACUTAP® VR®
VRL I 1801 ... 3201 - POTENTIAL CONNECTION UNIT WP/GP - RE
DIMENSION DRAWING

SERIAL NUMBER

MATERIAL NUMBER 101667680E SHEET 1/1

MASCHINENFABRIK REINHAUSEN GMBH COPYRIGHT RESERVED
 THE REPRODUCTION, DISTRIBUTION AND UTILIZATION OF THIS DOCUMENT AS WELL AS THE COMMUNICATION OF ITS CONTENTS TO OTHERS WITHOUT EXPRESS AUTHORIZATION IS PROHIBITED. OFFENDERS WILL BE HELD LIABLE FOR THE PAYMENT OF DAMAGES. ALL RIGHTS RESERVED IN THE EVENT OF THE GRANT OF A PATENT, UTILITY MODEL OR DESIGN.

DATE	NAME	DOCUMENT NO.
13.12.2021	RAEDLINGER	SED 8496246 001 00
13.12.2021	MENZELS	CHANGE NO.
14.12.2021	WANNINGER	1103709
DFTR.	SCALE	1:10
CHKO.		
STAND.		

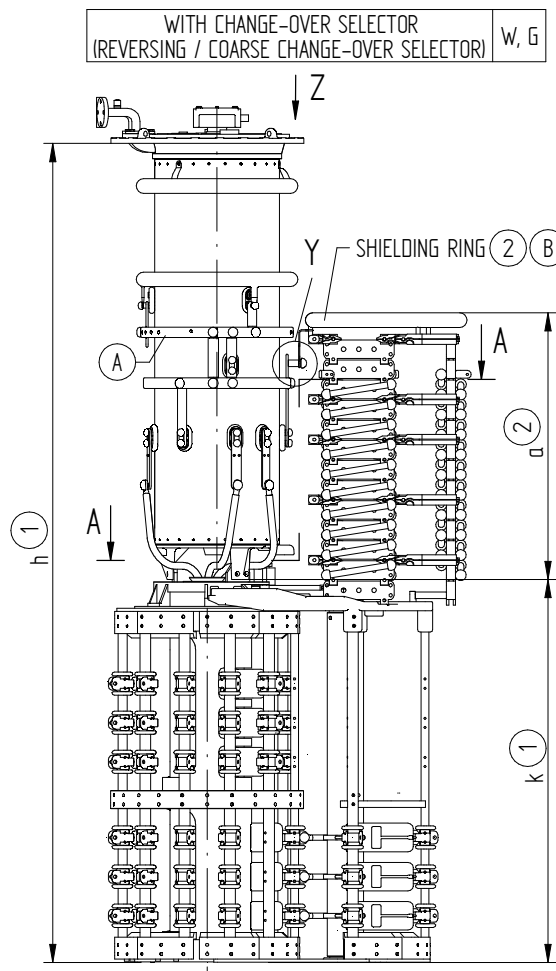

VRL I 2601 VARIANT DISPLAYED

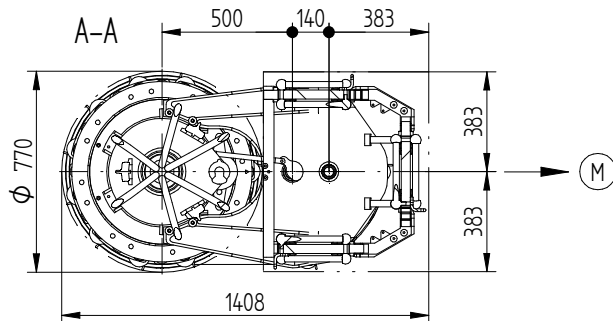
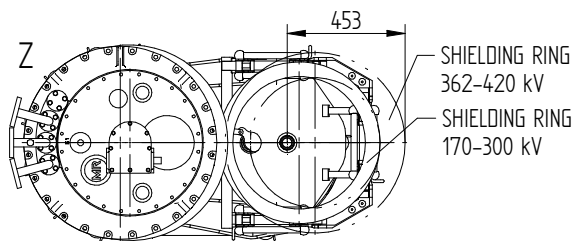

NUMBER AND POSITION OF CONNECTION CONTACT (2)

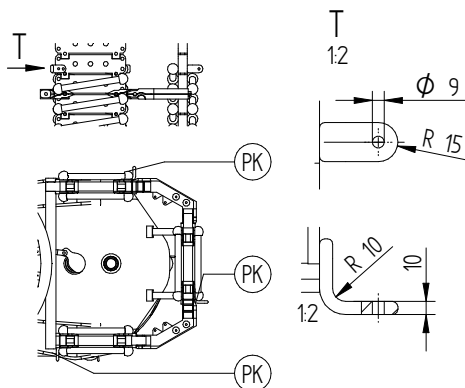

SCREW CONNECTION BETWEEN POTENTIAL CONNECTION UNIT AND CONNECTOR (2)

THE SCREW CONNECTION (IF AVAILABLE) IS MADE BY THE TRANSFORMER MANUFACTURER.

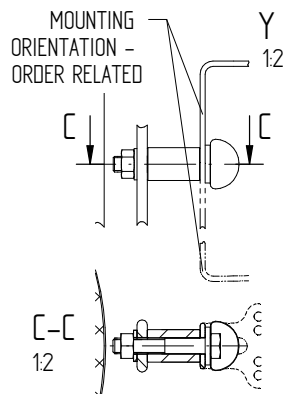

- (M) - DRIVE SIDE OF SELECTOR
- (A) - ON-LOAD TAP-CHANGER CURRENT TAKE-OFF TERMINAL
- (B) - IS CONNECTED TO POTENTIAL OF (A)
- (PK) - CONNECTION CONTACT
- (1) - REFER TO DIMENSION DRAWING
- (2) - IS ORDER RELATED, REFER TO ORDER RELATED DIMENSION DRAWING
- THE DETAILED CONNECTION DIAGRAM IS BINDING FOR THE DESIGNATION OF THE CONNECTION CONTACTS AND PHASES

PRODUCT RANGE POTENTIAL CONNECTION UNIT WITHOUT TIE-IN SWITCH WR/GR					
ON-LOAD TAP-CHANGER VACUTAP®	NUMBER PHASES	CIRCUIT RESISTORS	Um [kV]	POTENTIAL NUMBER OF RESISTORS PER PHASES	MAX. DIMENSIONS a [mm]
VRL I 1801	I	SERIES	72,5 ... 420	3 ... 22	678
VRL I 2001		PARALLEL		2x3 ... 2x22	968
VRL I 2401	I	3-FOLD PARALLEL	72,5 ... 362	3x3 ... 3x20	1063
VRL I 2601				420	3x3 ... 3x18
VRL I 3001					
VRL I 3201					

DIMENSION IN mm EXCEPT AS NOTED



ON-LOAD TAP-CHANGER VACUTAP® VR®
 VRL I 1801 ... 3201 - POTENTIAL CONNECTION UNIT WR/GR - RE
 DIMENSION DRAWING

SERIAL NUMBER

MATERIAL NUMBER 101667690E SHEET 1/1

© MASCHINENFABRIK REINHAUSEN GMBH 2016
 THE REPRODUCTION, DISTRIBUTION AND UTILIZATION OF THIS DOCUMENT AS WELL AS THE COMMUNICATION OF ITS CONTENTS TO OTHERS WITHOUT EXPRESS AUTHORIZATION IS PROHIBITED. OFFENDERS WILL BE HELD LIABLE FOR THE PAYMENT OF DAMAGES. ALL RIGHTS RESERVED IN THE EVENT OF THE GRANT OF A PATENT, UTILITY MODEL OR DESIGN.

WITH CHANGE-OVER SELECTOR
(REVERSING / COARSE CHANGE-OVER SELECTOR) W, G

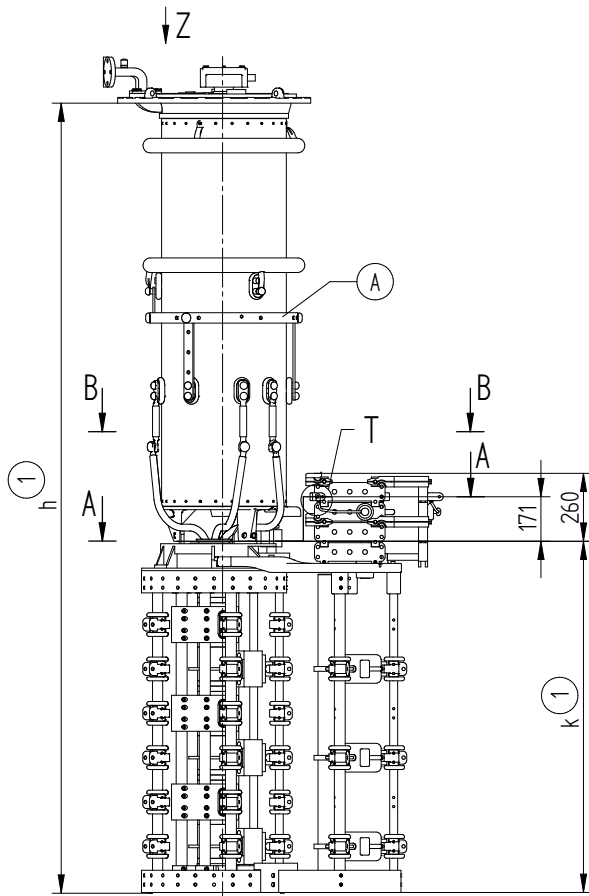

- (M) - DRIVE SIDE OF SELECTOR
 - (A) - ON-LOAD TAP-CHANGER CURRENT TAKE-OFF TERMINAL
 - (PK) - CONNECTION CONTACT
 - (PS) - TIE-IN SWITCH
 - (1) - REFER TO DIMENSION DRAWING
- THE DETAILED CONNECTION DIAGRAM IS BINDING FOR THE DESIGNATION OF THE CONNECTION CONTACTS AND PHASES

POSITION OF CONNECTION CONTACT - ORDER RELATED

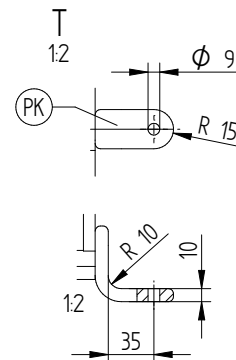

VRMIIIIY VARIANT DISPLAYED

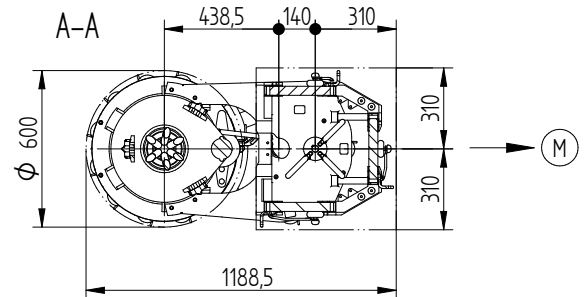
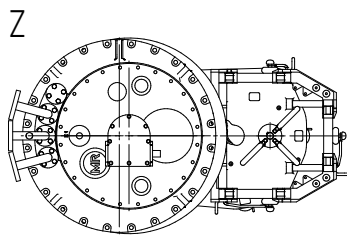

B-B

3-PHASE DESIGN

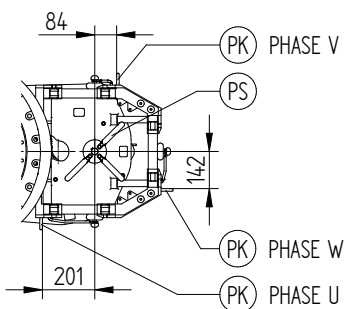

2-PHASE DESIGN

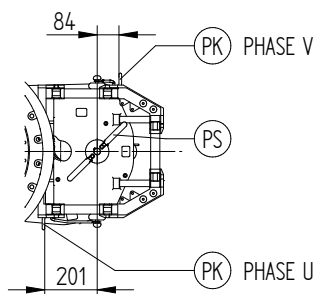

1-PHASE DESIGN

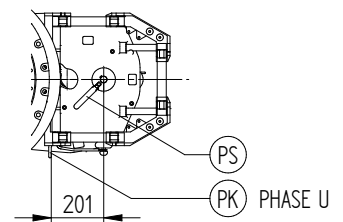

DATE	NAME	DOCUMENT NO.
18.10.2016	CTETPRAKTIK2	SED 5128451 001 01
19.10.2016	HILFNER	CHANGE NO.
20.10.2016	PRODASTSCHUK	1077548
DFTR.	SCALE	
CHKD.	1:10	
STAND.		

DIMENSION
IN mm
EXCEPT AS
NOTED



SELECTOR SIZE RC/RD/RDE
TIE-IN SWITCH WS/GS
DIMENSION DRAWING

SERIAL NUMBER

MATERIAL NUMBER SHEET
100177251E 1/1

© MASCHINENFABRIK REINHAUSEN GMBH 2016
 THE REPRODUCTION, DISTRIBUTION AND UTILIZATION OF THIS DOCUMENT AS WELL AS THE COMMUNICATION OF ITS CONTENTS TO OTHERS WITHOUT EXPRESS AUTHORIZATION IS PROHIBITED. OFFENDERS WILL BE HELD LIABLE FOR THE PAYMENT OF DAMAGES. ALL RIGHTS RESERVED IN THE EVENT OF THE GRANT OF A PATENT, UTILITY MODEL OR DESIGN.

WITH CHANGE-OVER SELECTOR
 (REVERSING / COARSE CHANGE-OVER SELECTOR) W, G

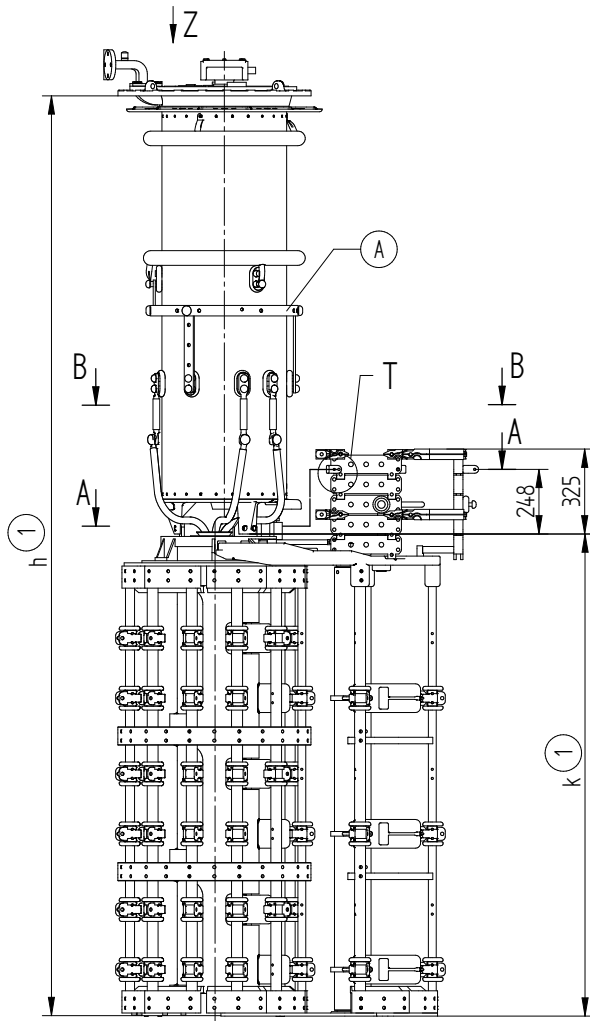

- (M) - DRIVE SIDE OF SELECTOR
 - (A) - ON-LOAD TAP-CHANGER CURRENT TAKE-OFF TERMINAL
 - (PK) - CONNECTION CONTACT
 - (PS) - TIE-IN SWITCH
 - (1) - REFER TO DIMENSION DRAWING
- THE DETAILED CONNECTION DIAGRAM IS BINDING FOR THE DESIGNATION OF THE CONNECTION CONTACTS AND PHASES

POSITION OF CONNECTION CONTACT - ORDER RELATED

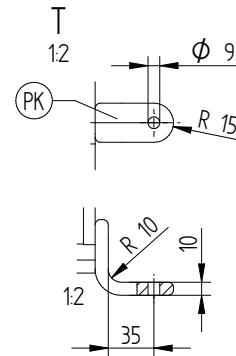

VRMIIII VARIANT DISPLAYED

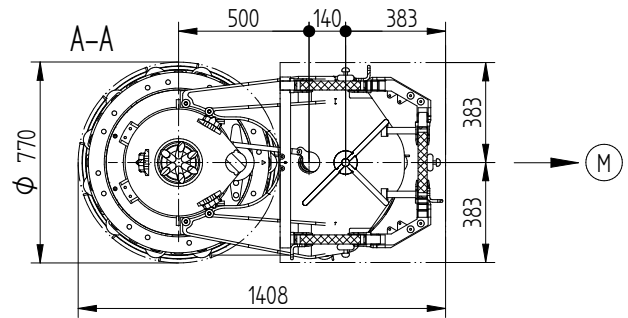
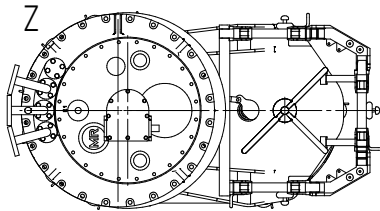

B-B

3-PHASE DESIGN

2-PHASE DESIGN

1-PHASE DESIGN

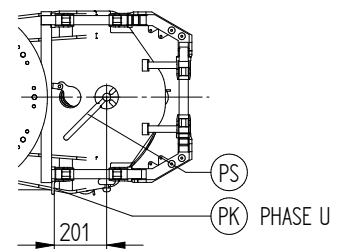
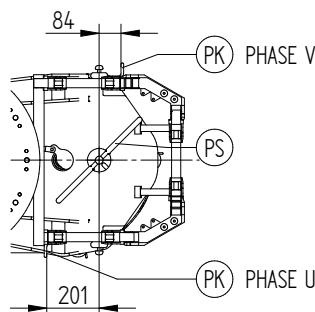
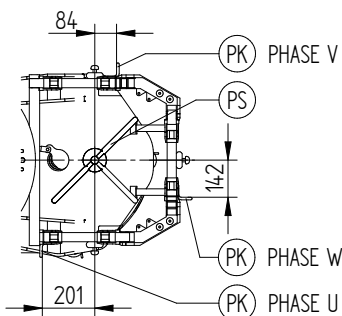

DIMENSION IN mm EXCEPT AS NOTED



SELECTOR SIZE RE/RF/RES
 TIE-IN SWITCH WS/GS
 DIMENSION DRAWING

SERIAL NUMBER

MATERIAL NUMBER 100175331E SHEET 1/1

DOCUMENT NO.	SED 5160555 001 00
NAME	CTETPRAKTIK2
DATE	18.10.2016
CHANGE NO.	1077548
SCALE	1:10
DFTR.	19.10.2016
CHKD.	20.10.2016
STAND.	PRODASTSCHUK

© MASCHINENFABRIK REINHAUSEN GMBH 2016
 THE REPRODUCTION, DISTRIBUTION AND UTILIZATION OF THIS DOCUMENT AS WELL AS THE COMMUNICATION OF ITS CONTENTS TO OTHERS WITHOUT EXPRESS AUTHORIZATION IS PROHIBITED. OFFENDERS WILL BE HELD LIABLE FOR THE PAYMENT OF DAMAGES. ALL RIGHTS RESERVED IN THE EVENT OF THE GRANT OF A PATENT, UTILITY MODEL OR DESIGN.

DATE	18.10.2016	DOCUMENT NO.	SED 1050468 001 07
DFTR.	19.10.2016	NAME	CTETPRAKTIK2
CHKD.	20.10.2016	CHANGE NO.	HILTNER 1077668
STAND.		SCALE	1:10
		PRODASTSCHUK	

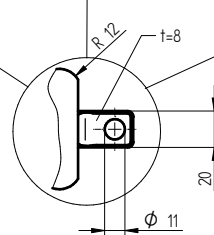
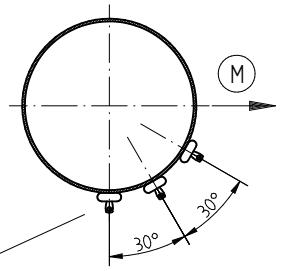
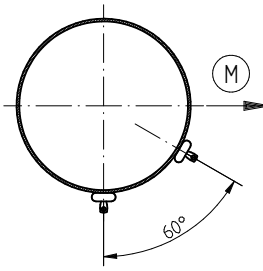
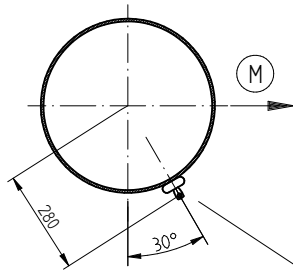
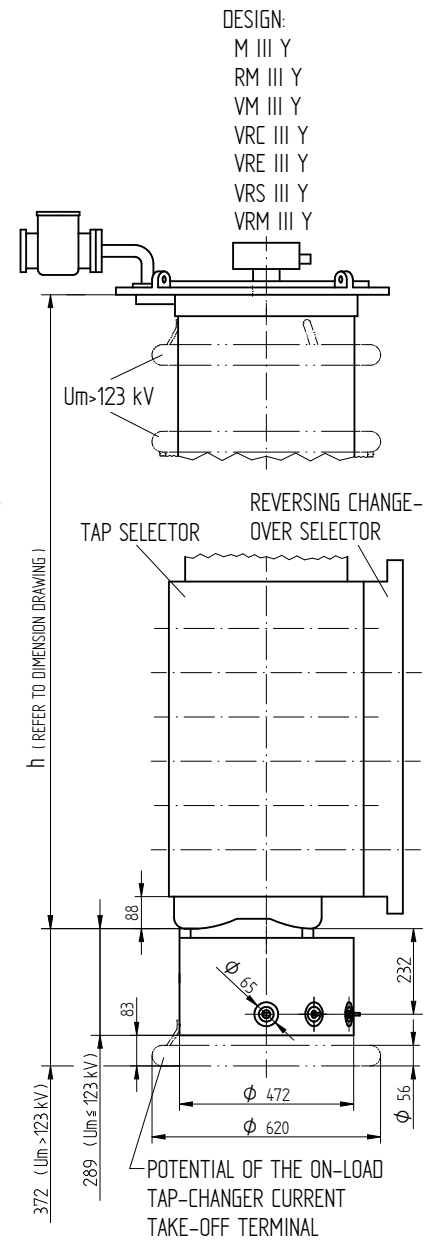
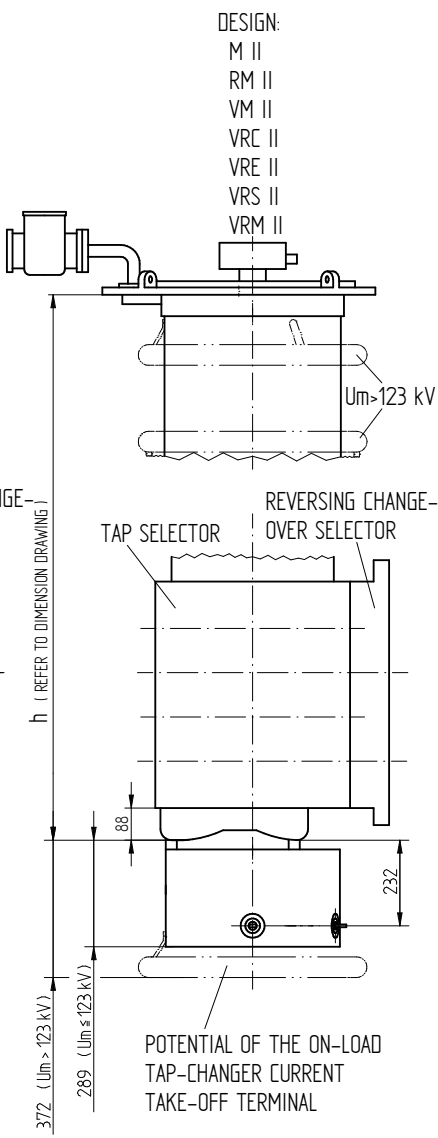
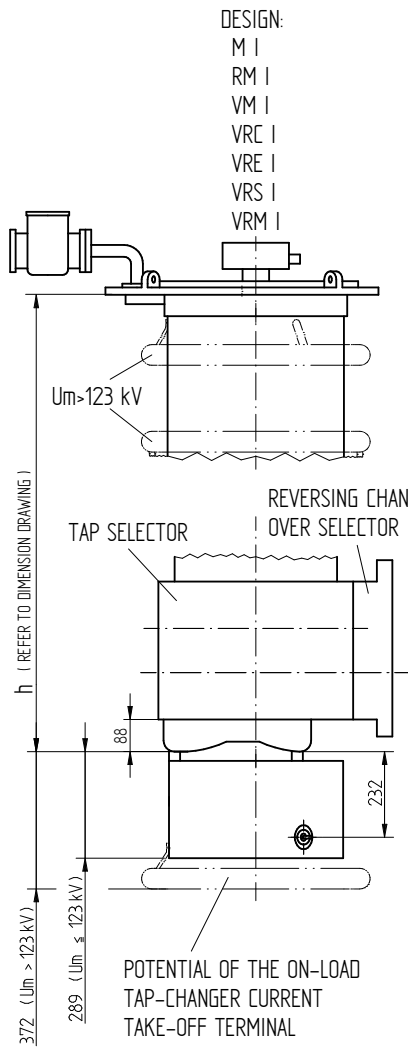

CONNECTION FOR EXTERNAL TIE-IN RESISTOR

(M) DRIVE SIDE OF SELECTOR

CONNECTING FROM TIE-IN SWITCH TO ON-LOAD TAP-CHANGER CURRENT TAKE-OFF TERMINAL IS CARRIED OUT BY MR THE DETAILED CONNECTION DIAGRAM IS BINDING FOR THE DESIGNATION OF THE CONNECTION CONTACTS AND PHASES

NOT APPLICABLE TO VM I 301, VM II 302 AND VM III 300 Y

DIMENSION
 IN mm
 EXCEPT AS
 NOTED



ON-LOAD TAP-CHANGER OILTAP®M, RM / VACUTAP® VM, VR
 M/RM/VM/VRC/VRE/VRS/VRM - REVERSING CHANGE-OVER SEL. - SIZE B/C/D/DE
 POTENTIAL CONNECTION UNIT WITH TIE-IN SWITCH WITHOUT TIE-IN RESISTORS

SERIAL NUMBER

MATERIAL NUMBER
 8988046E

SHEET
 1/1

© MASCHINENFABRIK REINHAUSEN GMBH 2016
 THE REPRODUCTION, DISTRIBUTION AND UTILIZATION OF THIS DOCUMENT AS WELL AS THE COMMUNICATION OF ITS CONTENTS TO OTHERS WITHOUT EXPRESS AUTHORIZATION IS PROHIBITED. OFFENDERS WILL BE HELD LIABLE FOR THE PAYMENT OF DAMAGES. ALL RIGHTS RESERVED IN THE EVENT OF THE GRANT OF A PATENT, UTILITY MODEL OR DESIGN.

DATE	18.10.2016	DOCUMENT NO.	SED 1665234 000 05
CHFKD.	19.10.2016	NAME	CTETPRAKTIK2
STAND.	20.10.2016	CHANGE NO.	HILTNER
		SCALE	1:10
			1077668
			PRODASTSCHUK

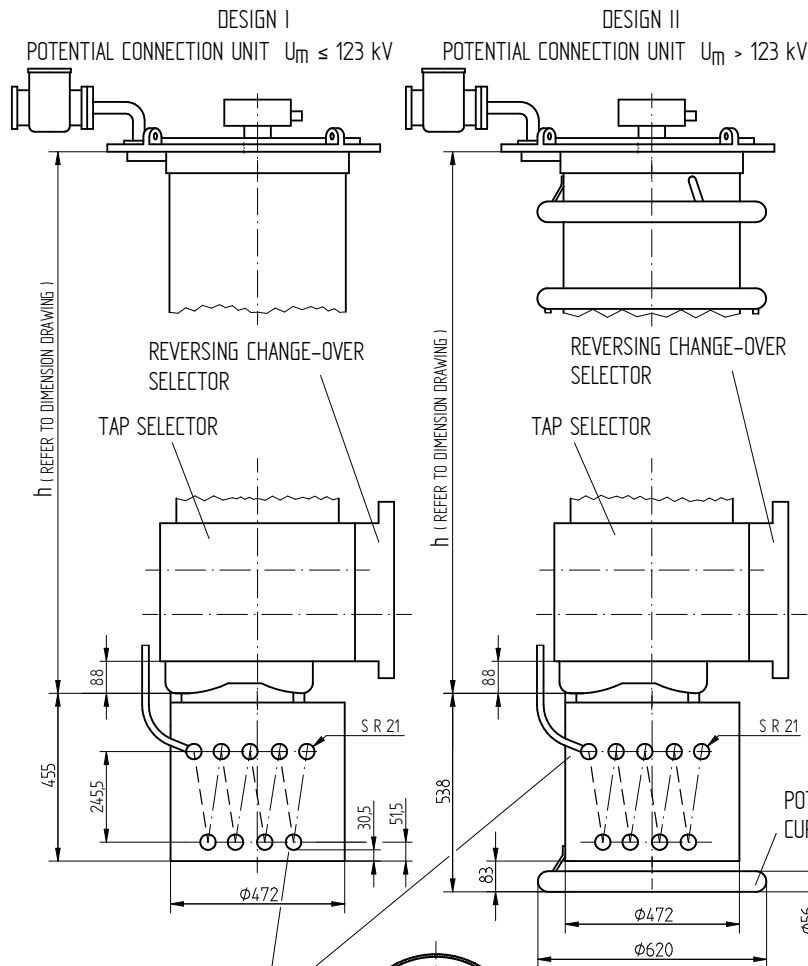

WITHOUT TIE-IN SWITCH
 FOR MAX. 8 RESISTOR ELEMENTS
 (AS SHOWN)

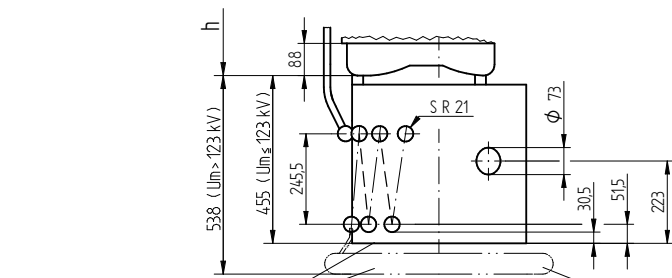
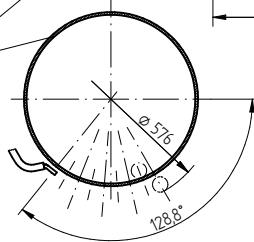

WITH TIE-IN SWITCH
 FOR MAX. 6 RESISTOR ELEMENTS
 (AS SHOWN)

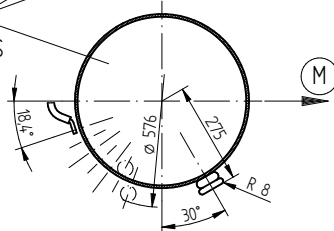

(M) DRIVE SIDE OF SELECTOR

THE DETAILED CONNECTION DIAGRAM IS BINDING FOR THE DESIGNATION OF THE CONNECTION CONTACTS AND PHASES
 CONNECTIONS FROM THE TIE-IN RESISTOR TO THE SELECTOR AND TO THE ON-LOAD TAP-CHANGER CURRENT TAKE-OFF TERMINAL ARE CARRIED OUT BY MR

NOT APPLICABLE TO VM I 301

ARRANGEMENT OF LEADS
 TIE-IN RESISTOR - SELECTOR
 FOR CONTACT LOCATION REFER TO RELEVANT DIMENSION DRAWING

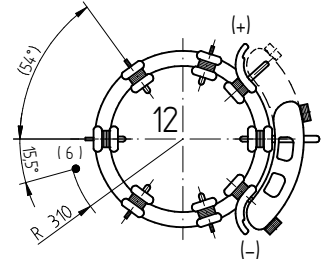
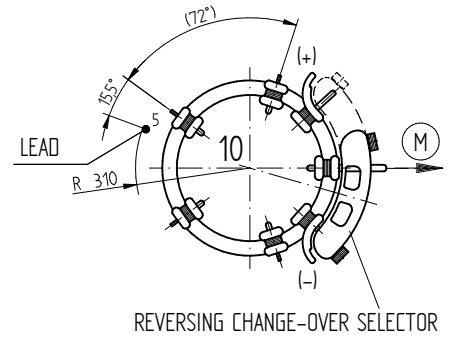

POTENTIAL OF THE ON-LOAD TAP-CHANGER
 CURRENT TAKE-OFF TERMINAL

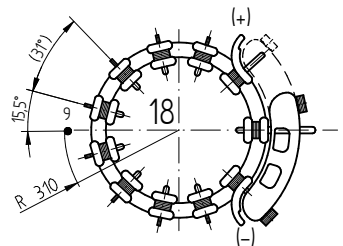
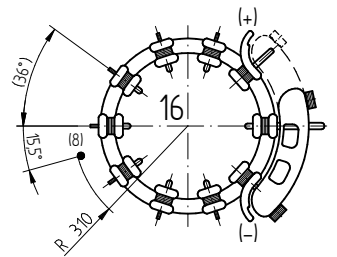
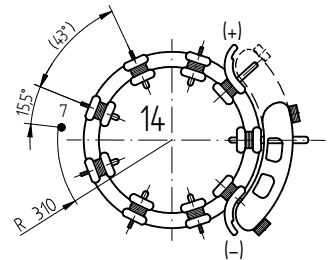

DIMENSION
 IN mm
 EXCEPT AS
 NOTED



ON-LOAD TAP-CHANGER OILTAP®M, RM / VACUTAP® VM, VR
 M/RM/VM/VRC/VRE/VRS/VRM I - REVERS. CHANGE-OVER SEL. - SIZE B/C/D/DE
 TIE-IN RESISTORS WITH/WITHOUT TIE-IN SWITCH

SERIAL NUMBER

MATERIAL NUMBER
 8986905E

SHEET
 1/1

© MASCHINENFABRIK REINHAUSEN GMBH 2016
 THE REPRODUCTION, DISTRIBUTION AND UTILIZATION OF THIS DOCUMENT AS WELL AS THE COMMUNICATION OF ITS CONTENTS TO OTHERS WITHOUT EXPRESS AUTHORIZATION IS PROHIBITED. OFFENDERS WILL BE HELD LIABLE FOR THE PAYMENT OF DAMAGES. ALL RIGHTS RESERVED IN THE EVENT OF THE GRANT OF A PATENT, UTILITY MODEL OR DESIGN.

DATE	20.10.2016	DOCUMENT NO.	SED 1665189 000 05
DFTR.	20.10.2016	NAME	CTETPRAKTIK2
CHKD.	20.10.2016	SCALE	1:10
STAND.	20.10.2016	CHANGE NO.	1077668
		PRODASTSCHUK	

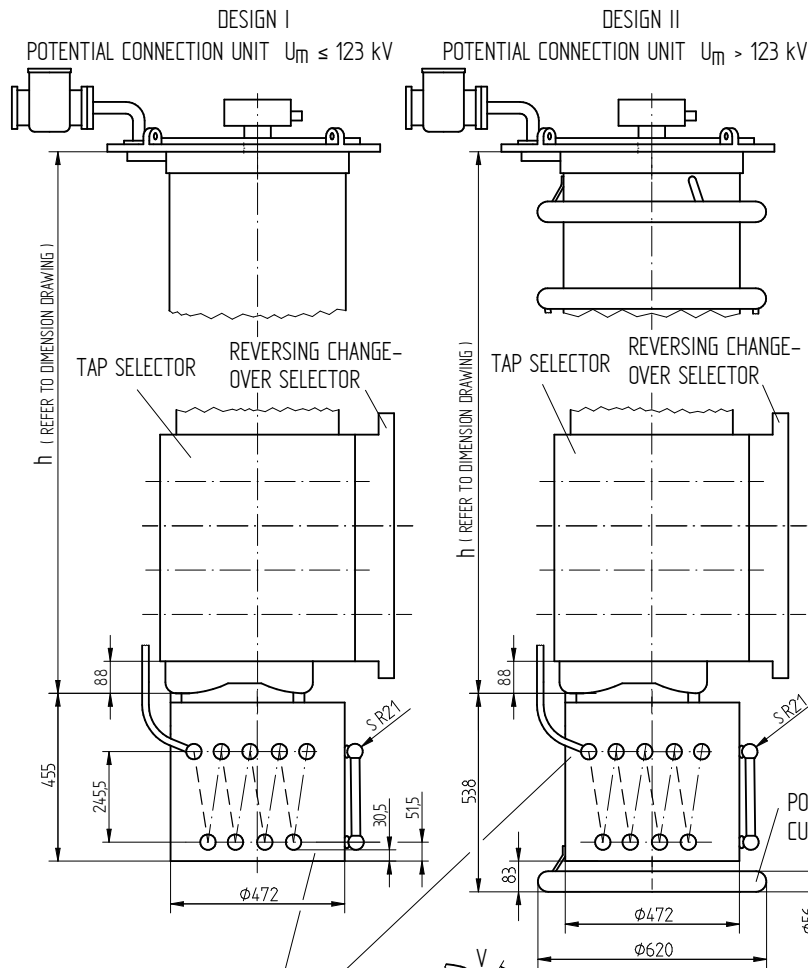

WITHOUT TIE-IN SWITCH
 FOR MAX. 8 RESISTOR
 ELEMENTS PER PHASE
 (AS SHOWN)

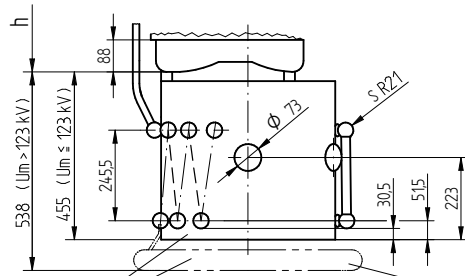
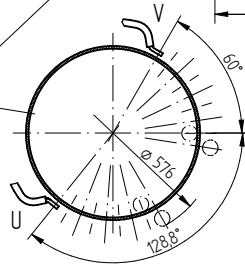

WITH TIE-IN SWITCH
 FOR MAX. 6 RESISTOR
 ELEMENTS PER PHASE
 (AS SHOWN)

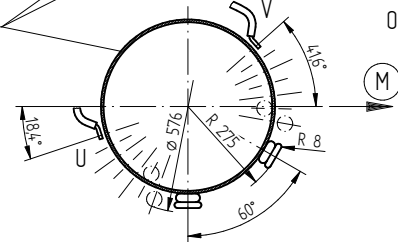

(M) DRIVE SIDE OF SELECTOR

THE DETAILED CONNECTION DIAGRAM IS BINDING FOR THE DESIGNATION OF THE CONNECTION CONTACTS AND PHASES
 CONNECTIONS FROM THE TIE-IN RESISTOR TO THE SELECTOR AND TO THE ON-LOAD TAP-CHANGER CURRENT TAKE-OFF TERMINAL ARE CARRIED OUT BY MR

NOT APPLICABLE TO VM II 302

ARRANGEMENT OF LEADS
 TIE-IN RESISTOR - PHASE
 FOR CONTACT LOCATION REFER TO
 RELEVANT DIMENSION DRAWING

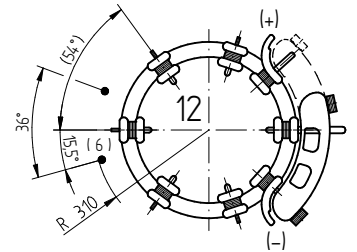
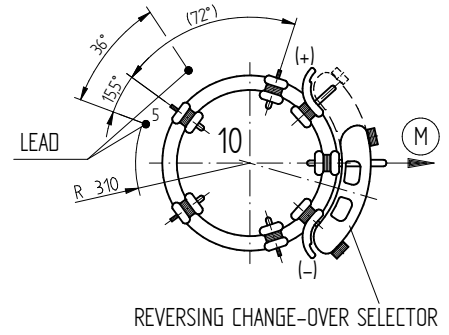

POTENTIAL OF THE ON-LOAD TAP-CHANGER
 CURRENT TAKE-OFF TERMINAL

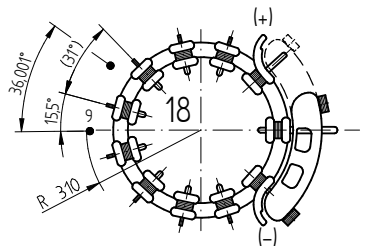
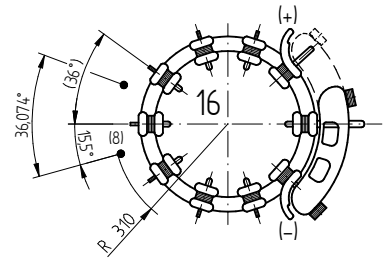
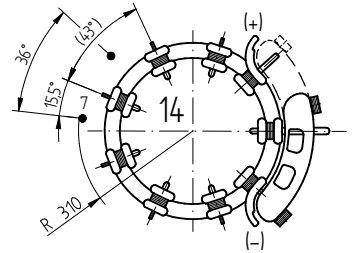

DIMENSION
 IN mm
 EXCEPT AS
 NOTED



ON-LOAD TAP-CHANGER OILTAP®M, RM / VACUTAP® VM, VR
 M/RM/VM/VRC/VRE/VRS/VRM II- REVERS. CHANGE-OVER SEL- SIZE B/C/D/DE
 TIE-IN RESISTORS WITH/WITHOUT TIE-IN SWITCH

SERIAL NUMBER

MATERIAL NUMBER
 8986915E

SHEET
 1/1

© MASCHINENFABRIK REINHAUSEN GMBH 2018
 THE REPRODUCTION, DISTRIBUTION AND UTILIZATION OF THIS DOCUMENT AS WELL AS THE COMMUNICATION OF ITS CONTENTS TO OTHERS WITHOUT EXPRESS AUTHORIZATION IS PROHIBITED. OFFENDERS WILL BE HELD LIABLE FOR THE PAYMENT OF DAMAGES. ALL RIGHTS RESERVED IN THE EVENT OF THE GRANT OF A PATENT, UTILITY MODEL OR DESIGN.

DATE	DOCUMENT NO.	NAME	SCALE
12.07.2018	SED 1665139 000 06	BUTERUS	1:10
CHKO. 16.07.2018	CHANGE NO.	WILHELM	
STAND. 16.07.2018	1086956	PRODASTSCHUK	

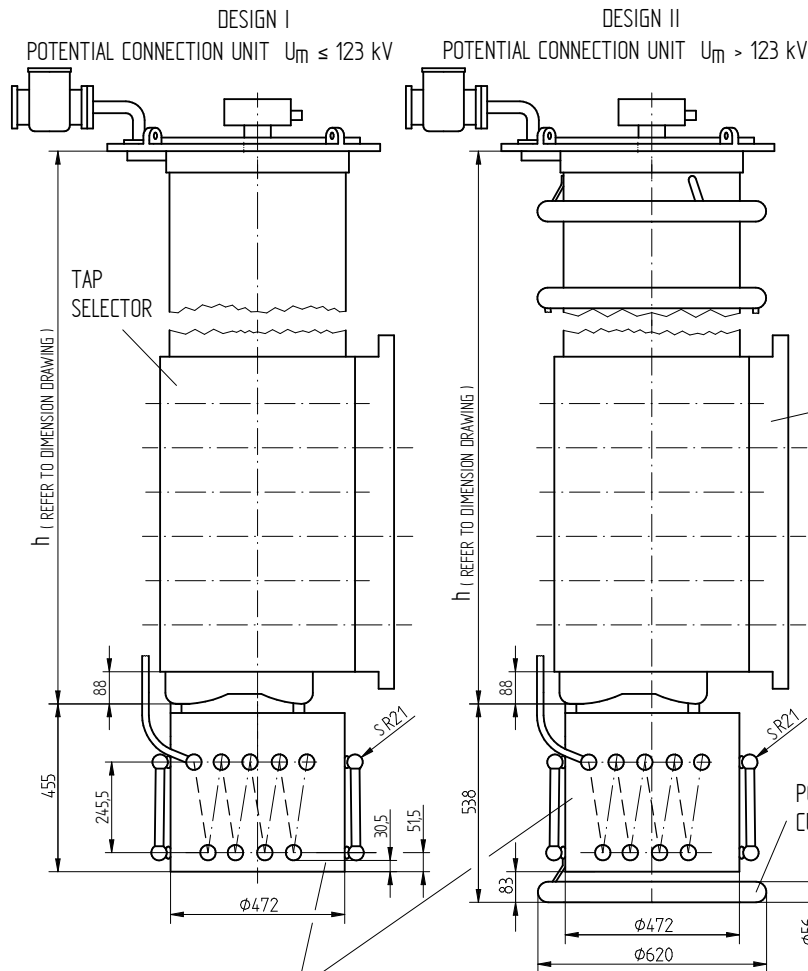

WITHOUT TIE-IN SWITCH
 FOR MAX. 8 RESISTOR
 ELEMENTS PER PHASE
 (AS SHOWN)

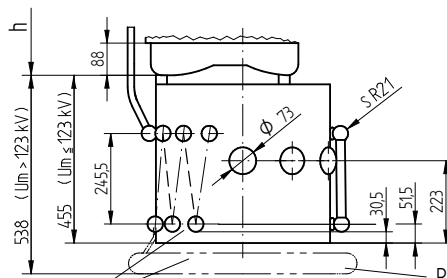
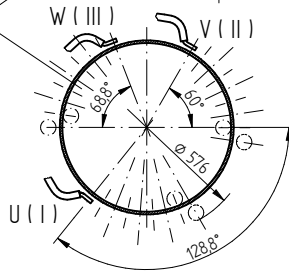

WITH TIE-IN SWITCH
 FOR MAX. 6 RESISTOR
 ELEMENTS PER PHASE
 (AS SHOWN)

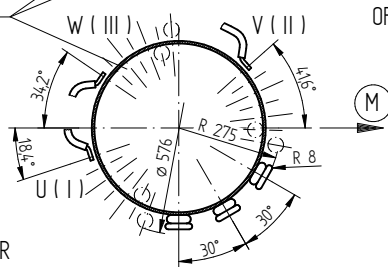

(M) DRIVE SIDE OF SELECTOR

THE DETAILED CONNECTION DIAGRAM IS BINDING FOR THE DESIGNATION OF THE CONNECTION CONTACTS AND PHASES
 CONNECTIONS FROM THE TIE-IN RESISTOR TO THE SELECTOR AND TO THE ON-LOAD TAP-CHANGER CURRENT TAKE-OFF TERMINAL ARE CARRIED OUT BY MR

NOT APPLICABLE TO VMS III 400 Y - B

ARRANGEMENT OF LEADS
 TIE-IN RESISTOR - PHASE
 FOR CONTACT LOCATION REFER TO
 RELEVANT DIMENSION DRAWING

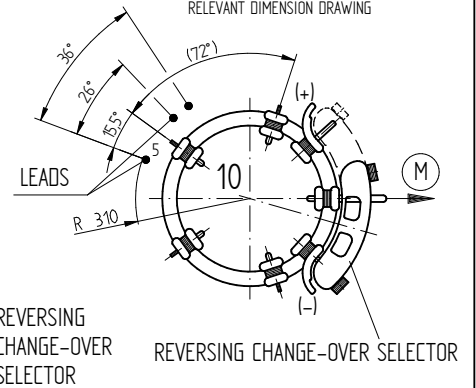

REVERSING
 CHANGE-OVER
 SELECTOR

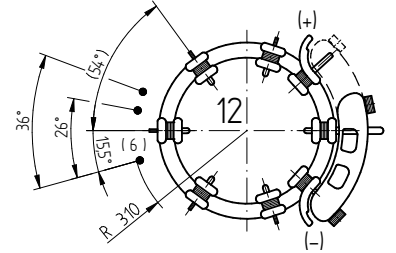

POTENTIAL OF THE ON-LOAD TAP-CHANGER
 CURRENT TAKE-OFF TERMINAL

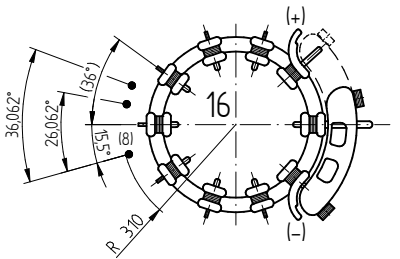
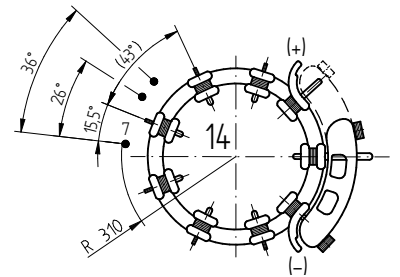

POTENTIAL OF THE MIDDLE
 OF THE TAP WINDING

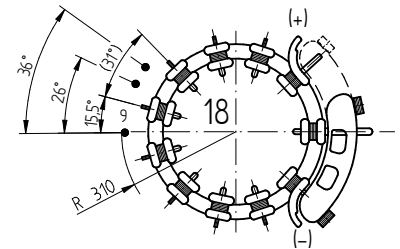

DIMENSION
 IN mm
 EXCEPT AS
 NOTED



OLTC OILTAP® M, RM / VACUTAP® VM®, VMS®-C, VR®
 M/RM/VM/VMS/VRC/VRE/VRS/VRM III Y - REV. COS - M-SEL. SIZE B/C/D/DE
 TIE-IN RESISTORS WITH / WITHOUT TIE-IN SWITCH

SERIAL NUMBER

MATERIAL NUMBER
 8986926E

SHEET
 1/1

© MASCHINENFABRIK REINHAUSEN GMBH 2016
 THE REPRODUCTION, DISTRIBUTION AND UTILIZATION OF THIS DOCUMENT AS WELL AS THE COMMUNICATION OF ITS CONTENTS TO OTHERS WITHOUT EXPRESS AUTHORIZATION IS PROHIBITED. OFFENDERS WILL BE HELD LIABLE FOR THE PAYMENT OF DAMAGES. ALL RIGHTS RESERVED IN THE EVENT OF THE GRANT OF A PATENT, UTILITY MODEL OR DESIGN.

DATE	18.10.2016	DOCUMENT NO.	SED 3378775 000 03
DFTR.	19.10.2016	NAME	CTETPRAKTIK2
CHKD.	20.10.2016	CHANGE NO.	HILTNER
STAND.		SCALE	1:10
			1077668
			PRODASTSCHUK

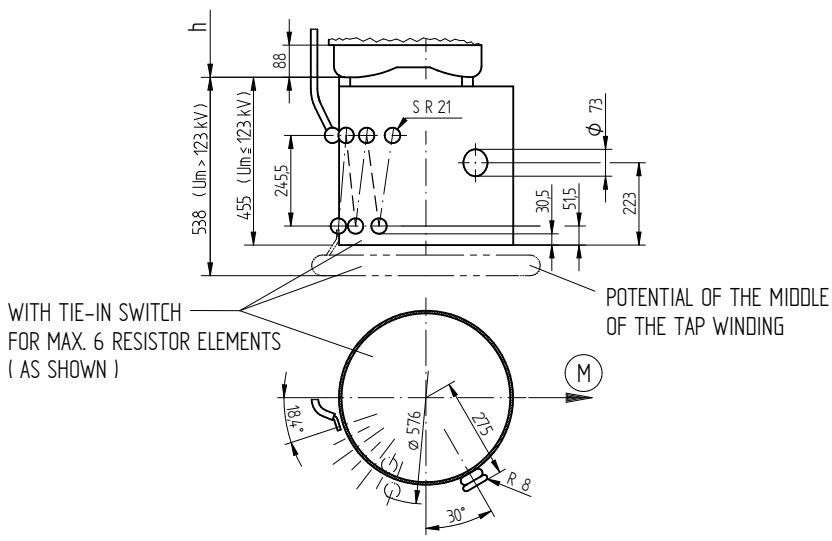
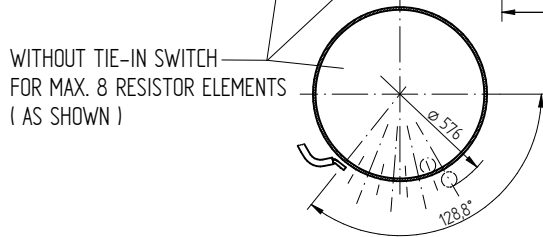
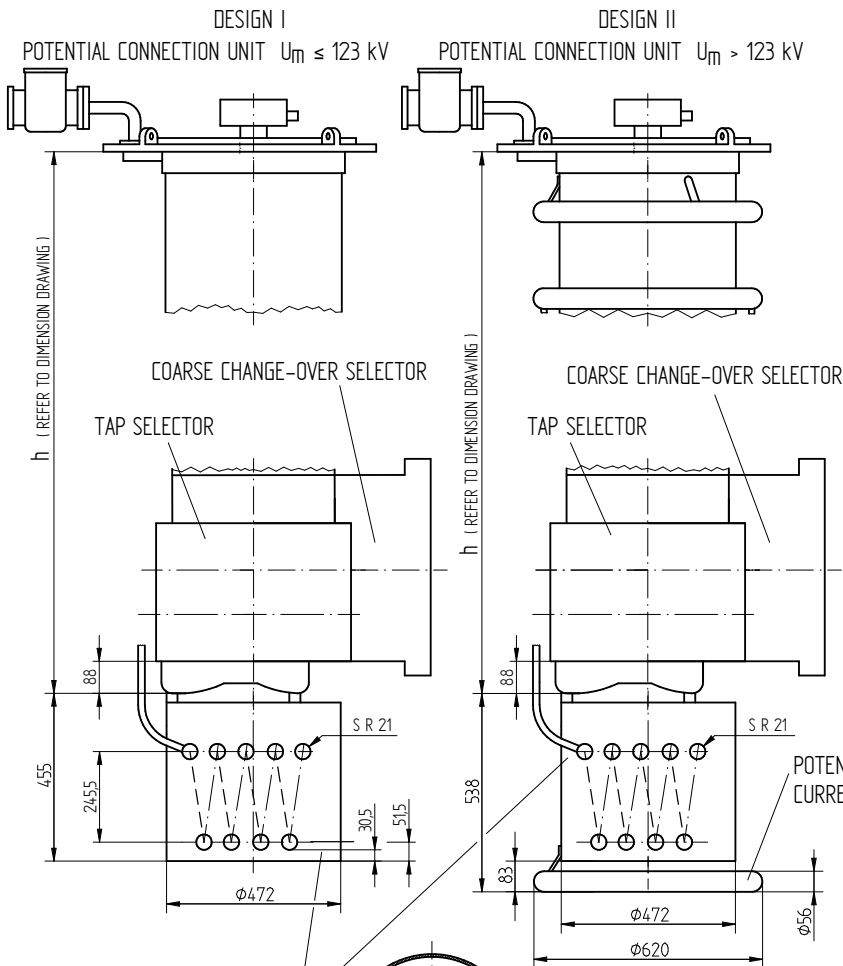

(M) DRIVE SIDE OF SELECTOR

THE DETAILED CONNECTION DIAGRAM IS BINDING FOR THE DESIGNATION OF THE CONNECTION CONTACTS AND PHASES
 CONNECTIONS FROM THE TIE-IN RESISTOR TO THE SELECTOR AND TO THE ON-LOAD TAP-CHANGER CURRENT TAKE-OFF TERMINAL ARE CARRIED OUT BY MR

NOT APPLICABLE TO VM I 301

ARRANGEMENT OF LEADS
 TIE-IN RESISTOR - SELECTOR

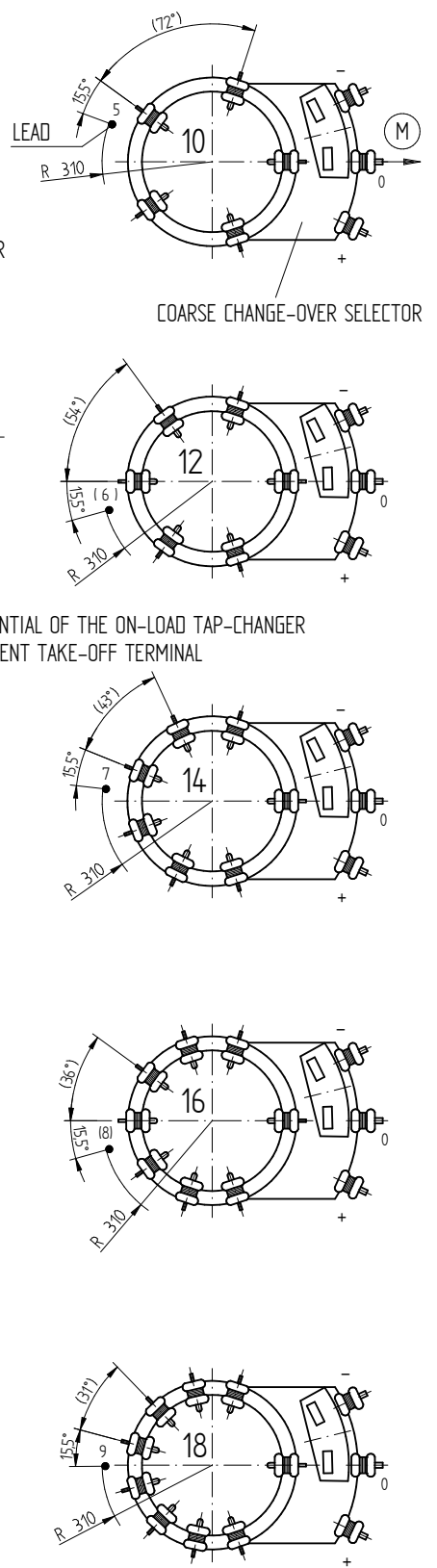

DIMENSION
 IN mm
 EXCEPT AS
 NOTED



ON-LOAD TAP-CHANGER OILTAP®M, RM / VACUTAP® VM, VR
 M/RM/VM/VRC/VRE/VRS/VRM I-COARSE CHANGE-OVER SELEC.-SIZE B/C/D/DE
 TIE-IN RESISTORS WITH/WITHOUT TIE-IN SWITCH

SERIAL NUMBER	
MATERIAL NUMBER	SHEET
7882662E	1/1

© MASCHINENFABRIK REINHAUSEN GMBH 2018
 THE REPRODUCTION, DISTRIBUTION AND UTILIZATION OF THIS DOCUMENT AS WELL AS THE COMMUNICATION OF ITS CONTENTS TO OTHERS WITHOUT EXPRESS AUTHORIZATION IS PROHIBITED. OFFENDERS WILL BE HELD LIABLE FOR THE PAYMENT OF DAMAGES. ALL RIGHTS RESERVED IN THE EVENT OF A PATENT, UTILITY MODEL OR DESIGN.

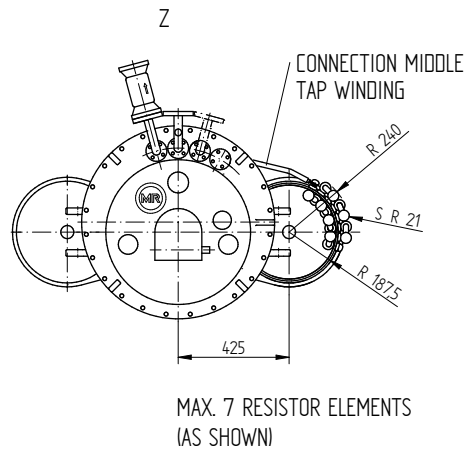
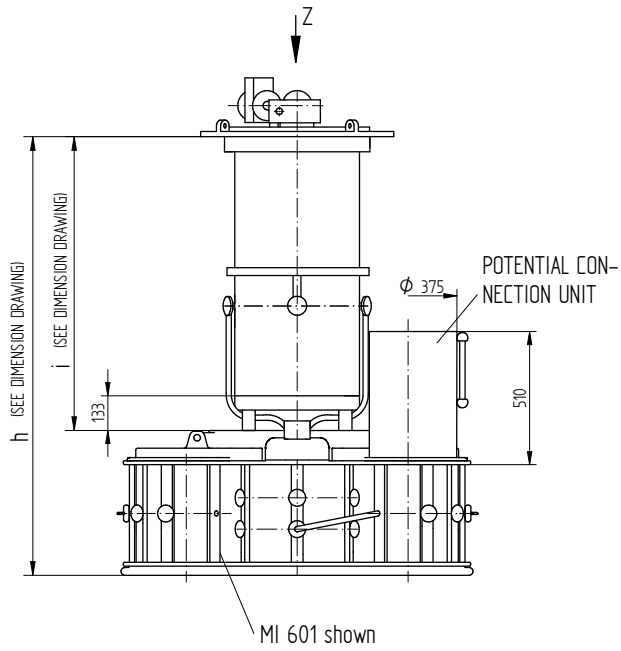

ARRANGEMENT OF SELECTOR CONTACTS,
 2-5 COARSE TAP CONNECTIONS
 (PLAN VIEW)

- x) FOR 3 COARSE TAP CONNECTIONS
- x) AND y) FOR 4 COARSE TAP CONNECTIONS
- x), y) AND z) FOR 5 COARSE TAP CONNECTIONS

CONNECTION MIDDLE TAP WINDING

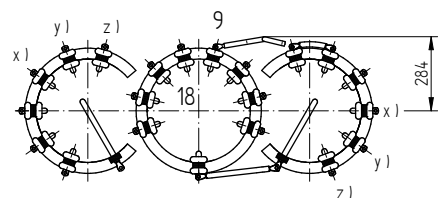
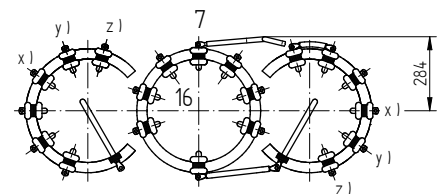
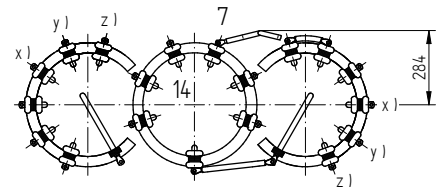
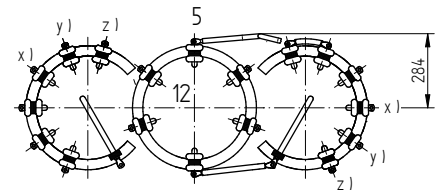
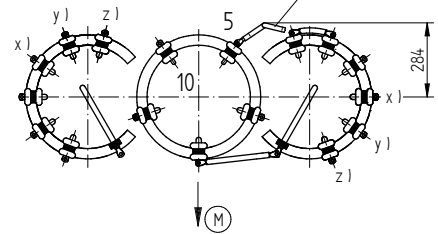

FOR BINDING DESIGNATIONS OF TERMINALS AND PHASES REFER TO THE CONNECTION DIAGRAM OF THE ON-LOAD TAP-CHANGER.

(M) DRIVE SIDE OF SELECTOR

DOCUMENT NO.	1062821 000 07
NAME	RAEDLINGER
DATE	19.04.2018
SCALE	1:10
CHANGE NO.	1087395
NAME	HAUER
DATE	25.04.2018
NAME	PRODASTSCHUK
DATE	25.04.2018

DIMENSION
 IN mm
 EXCEPT AS
 NOTED



ON-LOAD TAP-CHANGER OILTAP® M I AND VACUTAP® VM I, VRC I, VRS I, VRM I
 WITH MULTIPLE COARSE CHANGE-OVER SELECTOR
 MOUNTING OF TIE-IN RESISTORS - SELECTOR SIZE B/C/D

SERIAL NUMBER

MATERIAL NUMBER
 7197337E

SHEET
 1/1

4.7 결선도(예)

여기에 포함된 결선도는 예시일 뿐입니다.

순서별 결선도가 함께 제공됩니다.

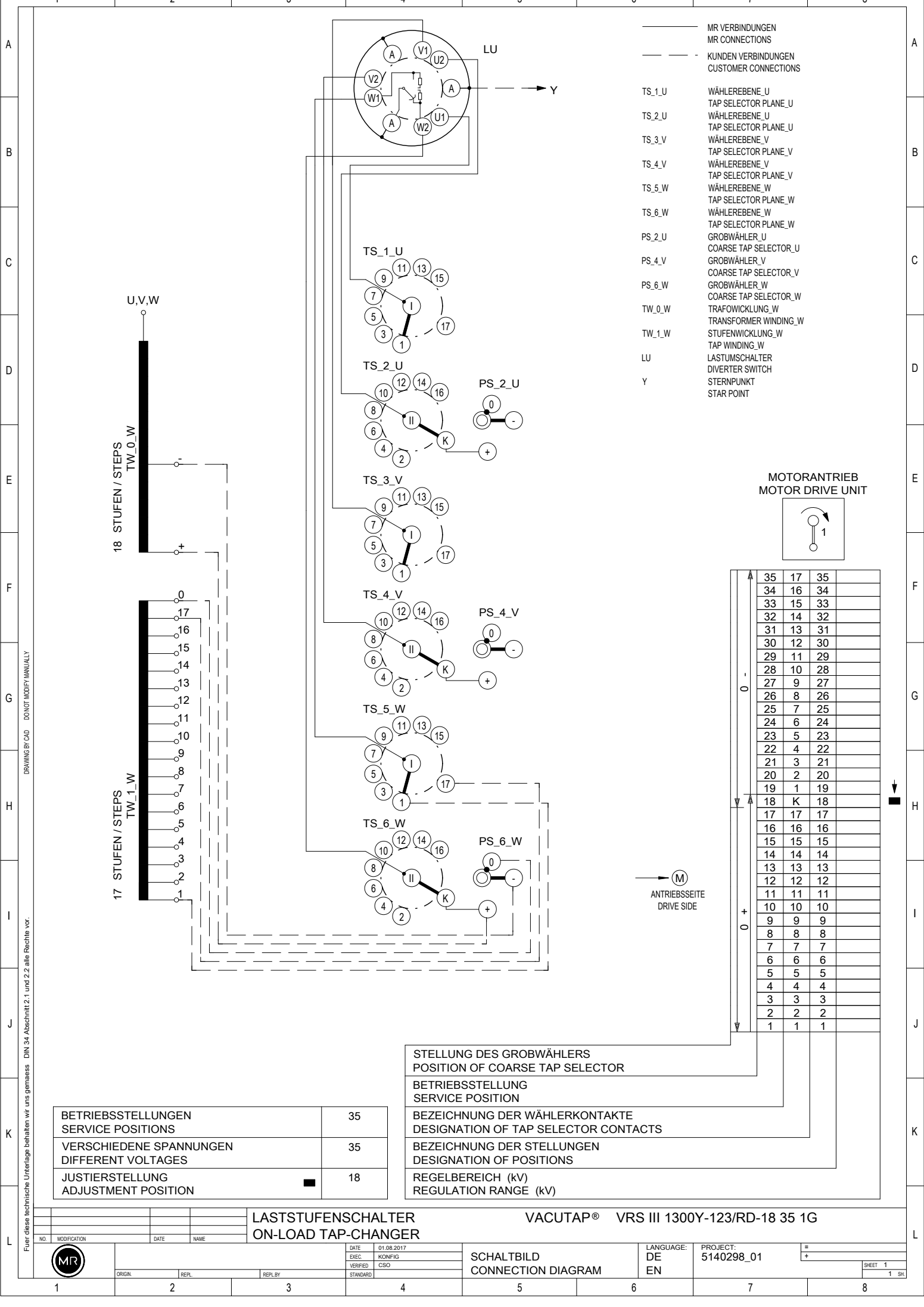

- MR VERBINDUNGEN
MR CONNECTIONS
- KUNDEN VERBINDUNGEN
CUSTOMER CONNECTIONS
- TS_1_U WÄHLEREbene_U
TAP SELECTOR PLANE_U
- TS_2_U WÄHLEREbene_U
TAP SELECTOR PLANE_U
- TS_3_V WÄHLEREbene_V
TAP SELECTOR PLANE_V
- TS_4_V WÄHLEREbene_V
TAP SELECTOR PLANE_V
- TS_5_W WÄHLEREbene_W
TAP SELECTOR PLANE_W
- TS_6_W WÄHLEREbene_W
TAP SELECTOR PLANE_W
- PS_2_U GROBWÄHLER_U
COARSE TAP SELECTOR_U
- PS_4_V GROBWÄHLER_V
COARSE TAP SELECTOR_V
- PS_6_W GROBWÄHLER_W
COARSE TAP SELECTOR_W
- TW_0_W TRAFOWICKLUNG_W
TRANSFORMER WINDING_W
- TW_1_W STUFENWICKLUNG_W
TAP WINDING_W
- LU LASTUMSCHALTER
DIVERTER SWITCH
- Y STERNPUNKT
STAR POINT



35	17	35
34	16	34
33	15	33
32	14	32
31	13	31
30	12	30
29	11	29
28	10	28
27	9	27
26	8	26
25	7	25
24	6	24
23	5	23
22	4	22
21	3	21
20	2	20
19	1	19
18	K	18
17	17	17
16	16	16
15	15	15
14	14	14
13	13	13
12	12	12
11	11	11
10	10	10
9	9	9
8	8	8
7	7	7
6	6	6
5	5	5
4	4	4
3	3	3
2	2	2
1	1	1

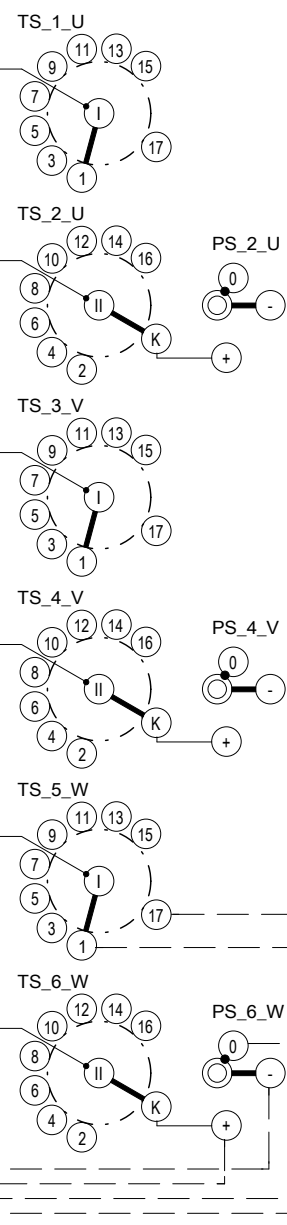
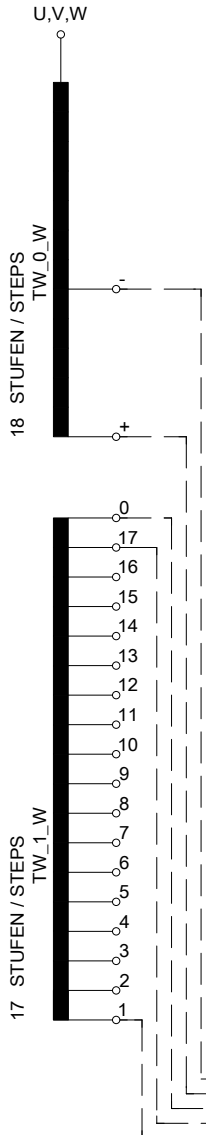

➔ (M)
ANTRIEBSSEITE
DRIVE SIDE

STELLUNG DES GROBWÄHLERS
POSITION OF COARSE TAP SELECTOR

BETRIEBSSTELLUNG
SERVICE POSITION

BEZEICHNUNG DER WÄHLERKONTAKTE
DESIGNATION OF TAP SELECTOR CONTACTS

BEZEICHNUNG DER STELLUNGEN
DESIGNATION OF POSITIONS

REGELBEREICH (kV)
REGULATION RANGE (kV)

BETRIEBSSTELLUNGEN SERVICE POSITIONS	35
VERSCHIEDENE SPANNUNGEN DIFFERENT VOLTAGES	35
JUSTIERSTELLUNG ADJUSTMENT POSITION	18

LASTSTUFENSCHALTER VACUTAP® VRS III 1300Y-123/RD-18 35 1G
ON-LOAD TAP-CHANGER

NO.	MODIFICATION	DATE	NAME



DATE	01.08.2017
ERIC	KONFIG
VERIFIED	CSO
STANDARD	

SCHALTBILD
CONNECTION DIAGRAM

LANGUAGE:
DE PROJECT: 5140298_01
EN

FÜR DIESE TECHNISCHE UNTERLAGE BEHALTEN WIR UNS GEMÄSS DIN 34 ABSCHNITT 2.1 UND 2.2 ALLE RECHTE VOR.
 DRAWING BY CAD DO NOT MODIFY MANUALLY

A
B
C
D
E
F
G
H
I
J
K
L

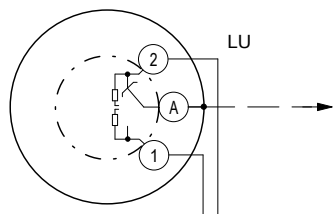

- MR VERBINDUNGEN
MR CONNECTIONS
- - - KUNDEN VERBINDUNGEN
CUSTOMER CONNECTIONS
- TS_1 WÄHLEREBENE
TAP SELECTOR PLANE
- TS_2 WÄHLEREBENE
TAP SELECTOR PLANE
- PS_2 WENDER
REVERSING CHANGE-OVER SELECTOR
- TW_0 TRAFOWICKLUNG
TRANSFORMER WINDING
- TW_1 STUFENWICKLUNG
TAP WINDING
- LU LASTUMSCHALTER
DIVERTER SWITCH

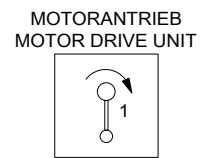
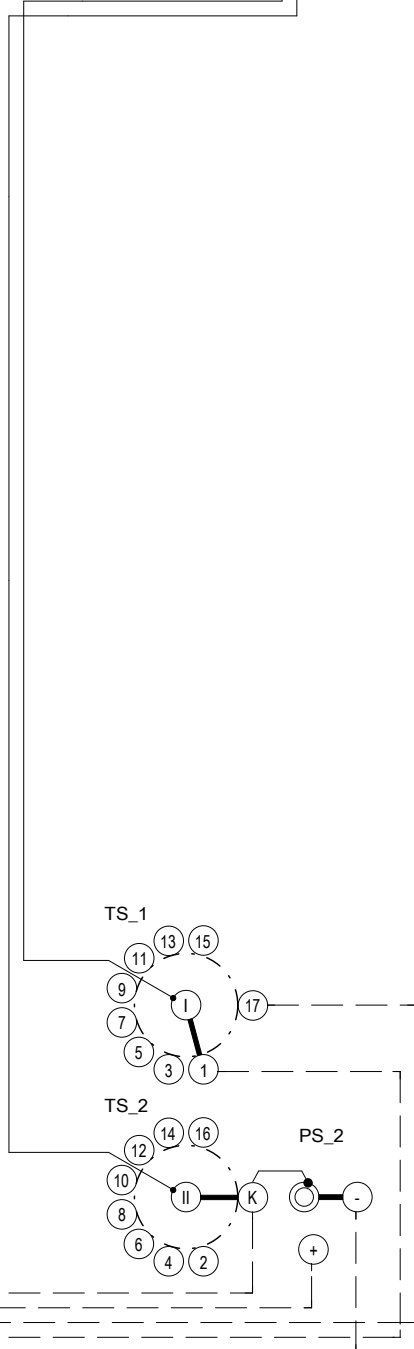
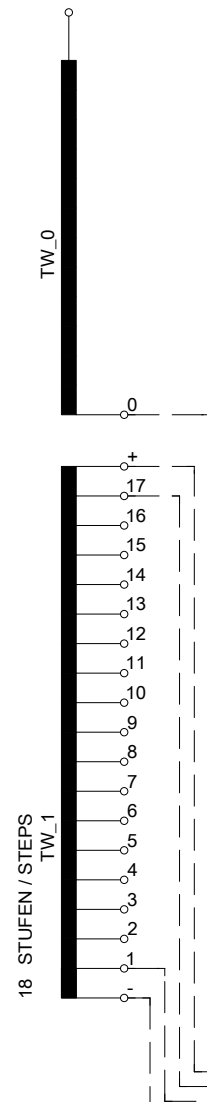

35	17	35
34	16	34
33	15	33
32	14	32
31	13	31
30	12	30
29	11	29
28	10	28
27	9	27
26	8	26
25	7	25
24	6	24
23	5	23
22	4	22
21	3	21
20	2	20
19	1	19
18	K	18
17	17	17
16	16	16
15	15	15
14	14	14
13	13	13
12	12	12
11	11	11
10	10	10
9	9	9
8	8	8
7	7	7
6	6	6
5	5	5
4	4	4
3	3	3
2	2	2
1	1	1

Ⓜ ANTRIEBSSEITE
DRIVE SIDE

STELLUNG DES WENDERS
POSITION OF REVERSING CHANGE-OVER SELECTOR

BETRIEBSSTELLUNG
SERVICE POSITION

BEZEICHNUNG DER WÄHLERKONTAKTE
DESIGNATION OF TAP SELECTOR CONTACTS

BEZEICHNUNG DER STELLUNGEN
DESIGNATION OF POSITIONS

REGELBEREICH (kV)
REGULATION RANGE (kV)

BETRIEBSSTELLUNGEN SERVICE POSITIONS	35
VERSCHIEDENE SPANNUNGEN DIFFERENT VOLTAGES	35
JUSTIERSTELLUNG ADJUSTMENT POSITION	18

LASTSTUFENSCHALTER ON-LOAD TAP-CHANGER VACUTAP® VRS I 1301-123/RD-18 35 1W

NO.	MODIFICATION	DATE	NAME

DATE	01.08.2017
ERIC	KONFIG
VERIFIED	CSO
STANDARD	

SCHALTBILD
CONNECTION DIAGRAM

LANGUAGE:	DE
EN	
PROJECT:	5140300_01

Für diese technische Unterlage behalten wir uns gemäss DIN 34 Abschnitt 2.1 und 2.2 alle Rechte vor. DRAWING BY CAD DO NOT MODIFY MANUALLY

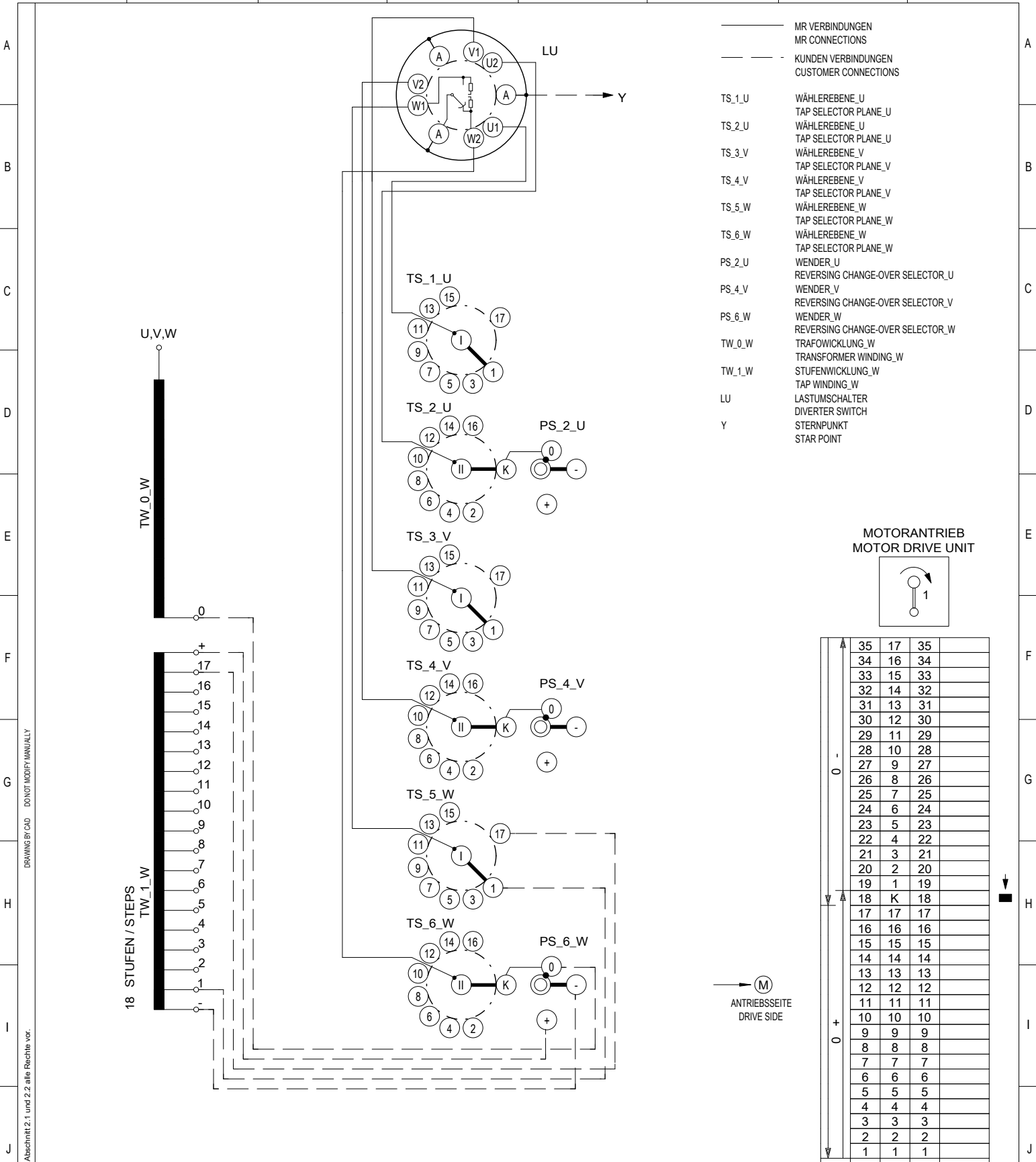

FÜR DIESE TECHNISCHE UNTERLAGE BEHALTEN WIR UNS GEMÄSS DIN 34 ABSCHNITT 2.1 UND 2.2 ALLE RECHTE VOR.
 DRAWING BY CAD DO NOT MODIFY MANUALLY

BETRIEBSSTELLUNGEN SERVICE POSITIONS	35
VERSCHIEDENE SPANNUNGEN DIFFERENT VOLTAGES	35
JUSTIERSTELLUNG ADJUSTMENT POSITION	18

STELLUNG DES WENDERS POSITION OF REVERSING CHANGE-OVER SELECTOR
BETRIEBSSTELLUNG SERVICE POSITION
BEZEICHNUNG DER WÄHLERKONTAKTE DESIGNATION OF TAP SELECTOR CONTACTS
BEZEICHNUNG DER STELLUNGEN DESIGNATION OF POSITIONS
REGELBEREICH (kV) REGULATION RANGE (kV)

LASTSTUFENSCHALTER VACUTAP® VRS III 1300Y-123/RE-18 35 1W
ON-LOAD TAP-CHANGER

NO.	MODIFICATION	DATE	NAME	DATE	01.08.2017	ERIC	KONFIG	SCHALTBILD CONNECTION DIAGRAM	LANGUAGE: DE EN	PROJECT: 5140417_02	= +
1							CSO				
2											
3											
4											
5											
6											
7											
8											



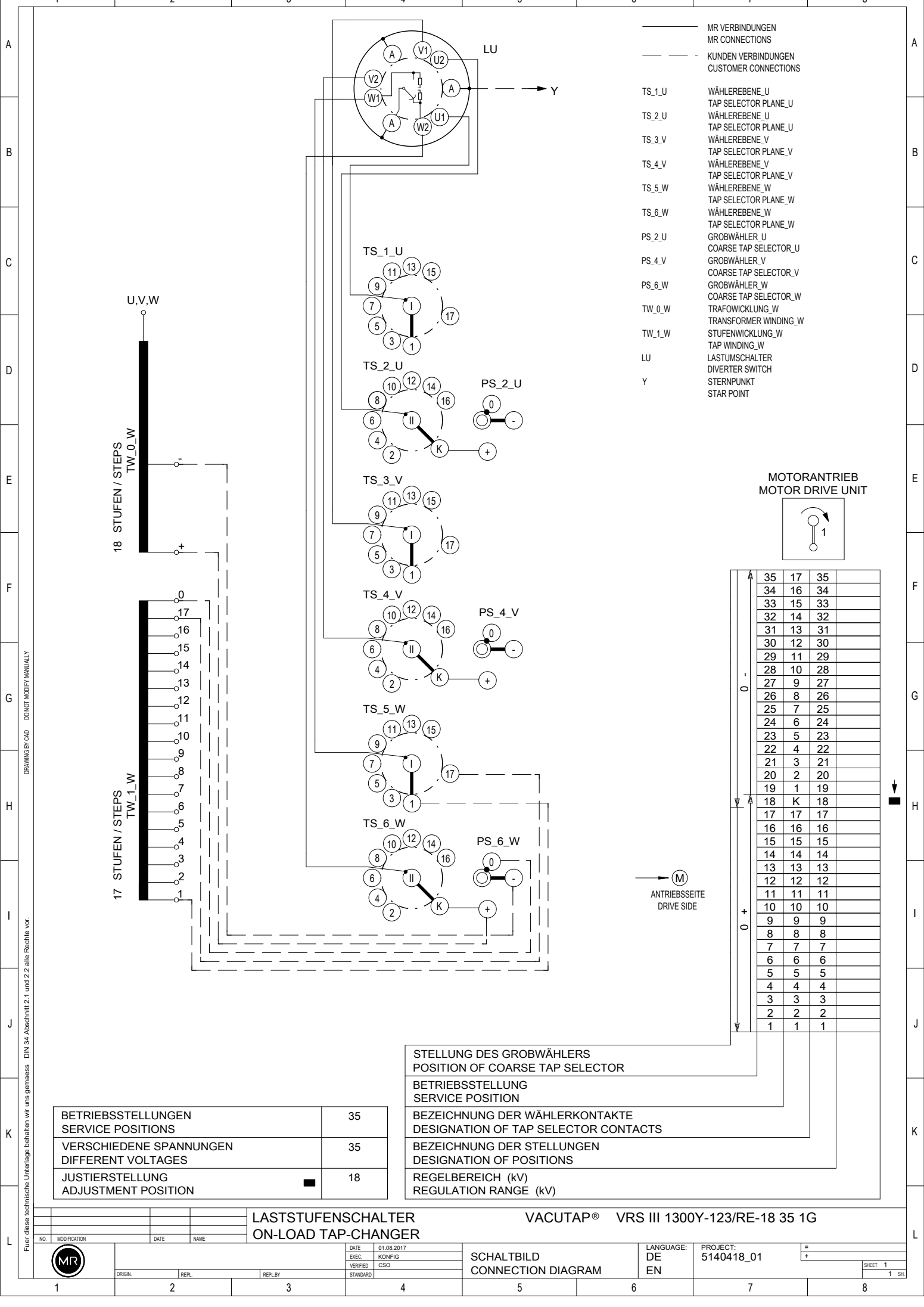

- MR VERBINDUNGEN
MR CONNECTIONS
- - - KUNDEN VERBINDUNGEN
CUSTOMER CONNECTIONS
- TS_1_U WÄHLEREbene_U
TAP SELECTOR PLANE_U
- TS_2_U WÄHLEREbene_U
TAP SELECTOR PLANE_U
- TS_3_V WÄHLEREbene_V
TAP SELECTOR PLANE_V
- TS_4_V WÄHLEREbene_V
TAP SELECTOR PLANE_V
- TS_5_W WÄHLEREbene_W
TAP SELECTOR PLANE_W
- TS_6_W WÄHLEREbene_W
TAP SELECTOR PLANE_W
- PS_2_U GROBwÄHLER_U
COARSE TAP SELECTOR_U
- PS_4_V GROBwÄHLER_V
COARSE TAP SELECTOR_V
- PS_6_W GROBwÄHLER_W
COARSE TAP SELECTOR_W
- TW_0_W TRAFOWICKLUNG_W
TRANSFORMER WINDING_W
- TW_1_W STUFENWICKLUNG_W
TAP WINDING_W
- LU LASTUMSCHALTER
DIVERter SWITCH
- Y STERNPUNKT
STAR POINT

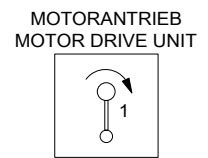

35	17	35
34	16	34
33	15	33
32	14	32
31	13	31
30	12	30
29	11	29
28	10	28
27	9	27
26	8	26
25	7	25
24	6	24
23	5	23
22	4	22
21	3	21
20	2	20
19	1	19
18	K	18
17	17	17
16	16	16
15	15	15
14	14	14
13	13	13
12	12	12
11	11	11
10	10	10
9	9	9
8	8	8
7	7	7
6	6	6
5	5	5
4	4	4
3	3	3
2	2	2
1	1	1

➔ (M)
ANTRIEBSSEITE
DRIVE SIDE

STELLUNG DES GROBwÄHLERS
POSITION OF COARSE TAP SELECTOR

BETRIEBSSTELLUNG
SERVICE POSITION

BEZEICHNUNG DER WÄHLERKONTAKTE
DESIGNATION OF TAP SELECTOR CONTACTS

BEZEICHNUNG DER STELLUNGEN
DESIGNATION OF POSITIONS

REGELBEREICH (kV)
REGULATION RANGE (kV)

BETRIEBSSTELLUNGEN SERVICE POSITIONS	35
VERSCHIEDENE SPANNUNGEN DIFFERENT VOLTAGES	35
JUSTIERSTELLUNG ADJUSTMENT POSITION	18

LASTSTUFENSCHALTER VACUTAP® VRS III 1300Y-123/RE-18 35 1G
ON-LOAD TAP-CHANGER

NO.	MODIFICATION	DATE	NAME

DATE	01.08.2017
ERIC	KONFIG
VERIFIED	CSO
STANDARD	

SCHALTBILD
CONNECTION DIAGRAM

LANGUAGE:
DE PROJECT:
EN 5140418_01

FÜR DIESE TECHNISCHE UNTERLAGE BEHALTEN WIR UNS GEMÄSS DIN 34 ABSCHNITT 2.1 UND 2.2 ALLE RECHTE VOR.
 DRAWING BY CAD DO NOT MODIFY MANUALLY

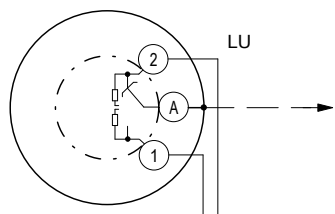

- MR VERBINDUNGEN
MR CONNECTIONS
- - - KUNDEN VERBINDUNGEN
CUSTOMER CONNECTIONS
- TS_1 WÄHLEREBENE
TAP SELECTOR PLANE
- TS_2 WÄHLEREBENE
TAP SELECTOR PLANE
- PS_2 WENDER
REVERSING CHANGE-OVER SELECTOR
- TW_0 TRAFOWICKLUNG
TRANSFORMER WINDING
- TW_1 STUFENWICKLUNG
TAP WINDING
- LU LASTUMSCHALTER
DIVERTER SWITCH

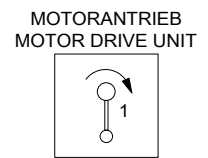
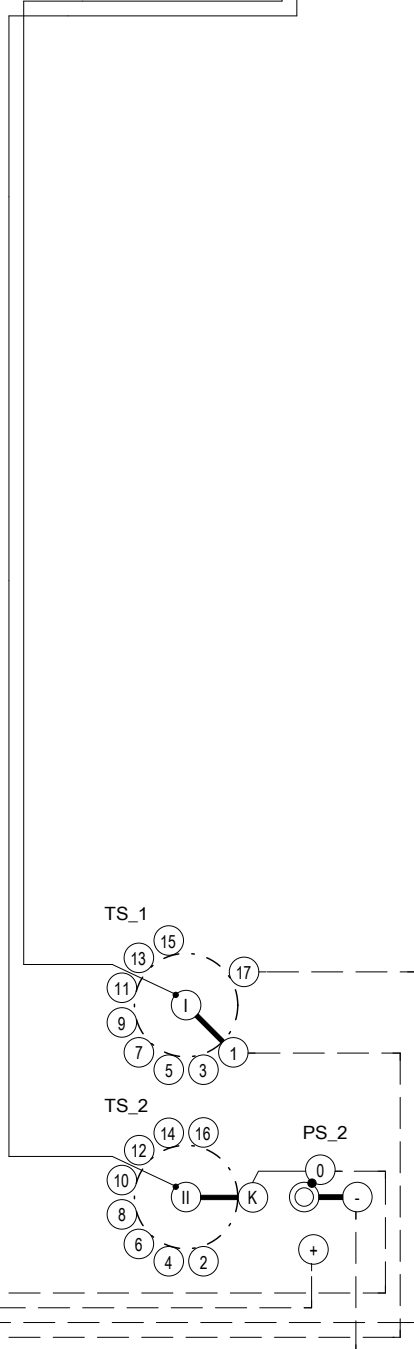
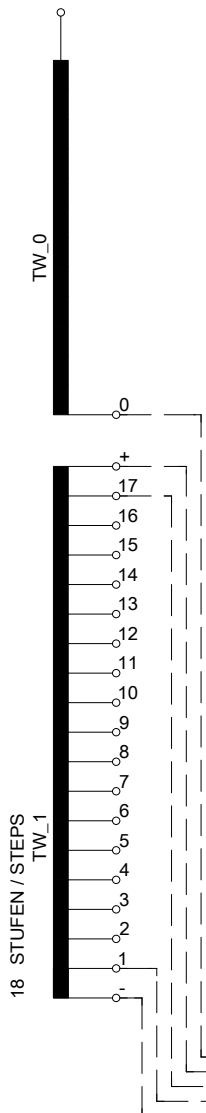

35	17	35
34	16	34
33	15	33
32	14	32
31	13	31
30	12	30
29	11	29
28	10	28
27	9	27
26	8	26
25	7	25
24	6	24
23	5	23
22	4	22
21	3	21
20	2	20
19	1	19
18	K	18
17	17	17
16	16	16
15	15	15
14	14	14
13	13	13
12	12	12
11	11	11
10	10	10
9	9	9
8	8	8
7	7	7
6	6	6
5	5	5
4	4	4
3	3	3
2	2	2
1	1	1

Ⓜ ANTRIEBSSEITE
DRIVE SIDE

STELLUNG DES WENDERS
POSITION OF REVERSING CHANGE-OVER SELECTOR

BETRIEBSSTELLUNG
SERVICE POSITION

BEZEICHNUNG DER WÄHLERKONTAKTE
DESIGNATION OF TAP SELECTOR CONTACTS

BEZEICHNUNG DER STELLUNGEN
DESIGNATION OF POSITIONS

REGELBEREICH (kV)
REGULATION RANGE (kV)

BETRIEBSSTELLUNGEN SERVICE POSITIONS	35
VERSCHIEDENE SPANNUNGEN DIFFERENT VOLTAGES	35
JUSTIERSTELLUNG ADJUSTMENT POSITION	18

LASTSTUFENSCHALTER VACUTAP® VRS I 1301-123/RE-18 35 1W
ON-LOAD TAP-CHANGER

NO.	MODIFICATION	DATE	NAME

DATE	01.08.2017
ERIC	KONFIG
VERIFIED	CSO
STANDARD	

SCHALTBILD
CONNECTION DIAGRAM

LANGUAGE:
DE EN
PROJECT:
5140419_02

Für diese technische Unterlage behalten wir uns gemäss DIN 34 Abschnitt 2.1 und 2.2 alle Rechte vor. DRAWING BY CAD - DO NOT MODIFY MANUALLY

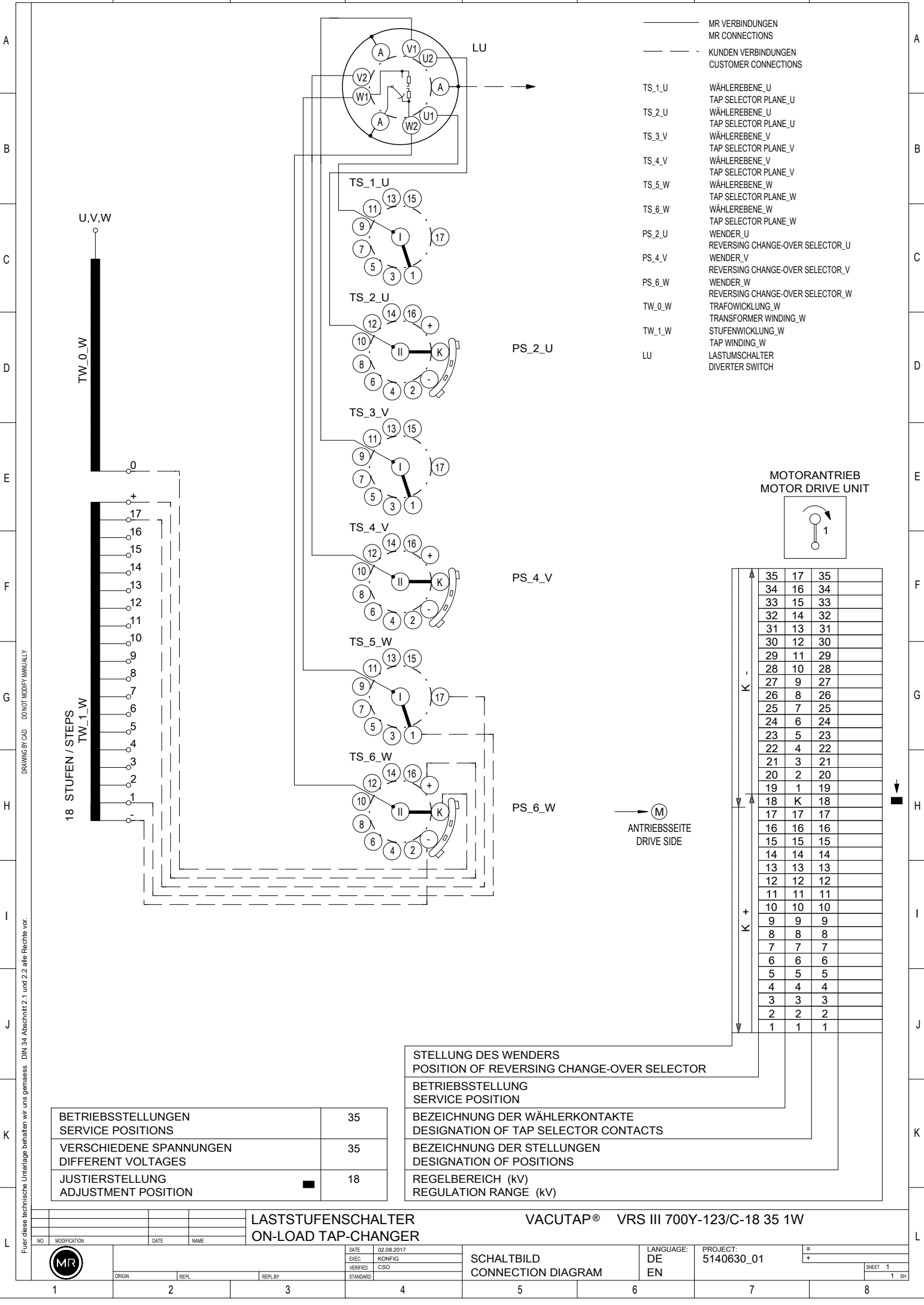

- MR VERBINDUNGEN
MR CONNECTIONS
- - - KUNDEN VERBINDUNGEN
CUSTOMER CONNECTIONS
- TS_1_U WÄHLEREBENE_U
TAP SELECTOR PLANE_U
- TS_2_U WÄHLEREBENE_U
TAP SELECTOR PLANE_U
- TS_3_V WÄHLEREBENE_V
TAP SELECTOR PLANE_V
- TS_4_V WÄHLEREBENE_V
TAP SELECTOR PLANE_V
- TS_5_W WÄHLEREBENE_W
TAP SELECTOR PLANE_W
- TS_6_W WÄHLEREBENE_W
TAP SELECTOR PLANE_W
- PS_2_U WENDER_U
REVERSING CHANGE-OVER SELECTOR_U
- PS_4_V WENDER_V
REVERSING CHANGE-OVER SELECTOR_V
- PS_6_W WENDER_W
REVERSING CHANGE-OVER SELECTOR_W
- TW_0_W TRAFOWICKLUNG_W
TRANSFORMER WINDING_W
- TW_1_W STUFENWICKLUNG_W
TAP WINDING_W
- LU LASTUMSCHALTER
DIVERTER SWITCH

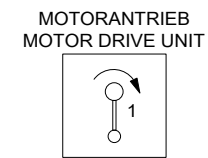

35	17	35
34	16	34
33	15	33
32	14	32
31	13	31
30	12	30
29	11	29
28	10	28
27	9	27
26	8	26
25	7	25
24	6	24
23	5	23
22	4	22
21	3	21
20	2	20
19	1	19
18	K	18
17	17	17
16	16	16
15	15	15
14	14	14
13	13	13
12	12	12
11	11	11
10	10	10
9	9	9
8	8	8
7	7	7
6	6	6
5	5	5
4	4	4
3	3	3
2	2	2
1	1	1

(M) ANTRIEBSSEITE
DRIVE SIDE

STELLUNG DES WENDERS
POSITION OF REVERSING CHANGE-OVER SELECTOR

BETRIEBSSTELLUNG
SERVICE POSITION

BEZEICHNUNG DER WÄHLERKONTAKTE
DESIGNATION OF TAP SELECTOR CONTACTS

BEZEICHNUNG DER STELLUNGEN
DESIGNATION OF POSITIONS

REGELBEREICH (kV)
REGULATION RANGE (kV)

BETRIEBSSTELLUNGEN SERVICE POSITIONS	35
VERSCHIEDENE SPANNUNGEN DIFFERENT VOLTAGES	35
JUSTIERSTELLUNG ADJUSTMENT POSITION	18

LASTSTUFENSCHALTER VACUTAP® VRS III 700Y-123/C-18 35 1W
ON-LOAD TAP-CHANGER

NO.	MODIFICATION	DATE	NAME

DATE	02.08.2017
ERIC	KONFIG
VERIFIED	CSO
STANDARD	

SCHALTBILD
CONNECTION DIAGRAM

LANGUAGE:	DE	PROJECT:	5140630_01
	EN		

DRAWING BY CAD - DO NOT MODIFY MANUALLY

Für diese technische Unterlage behalten wir uns gemäss DIN 34 Abschnitt 2.1 und 2.2 alle Rechte vor.

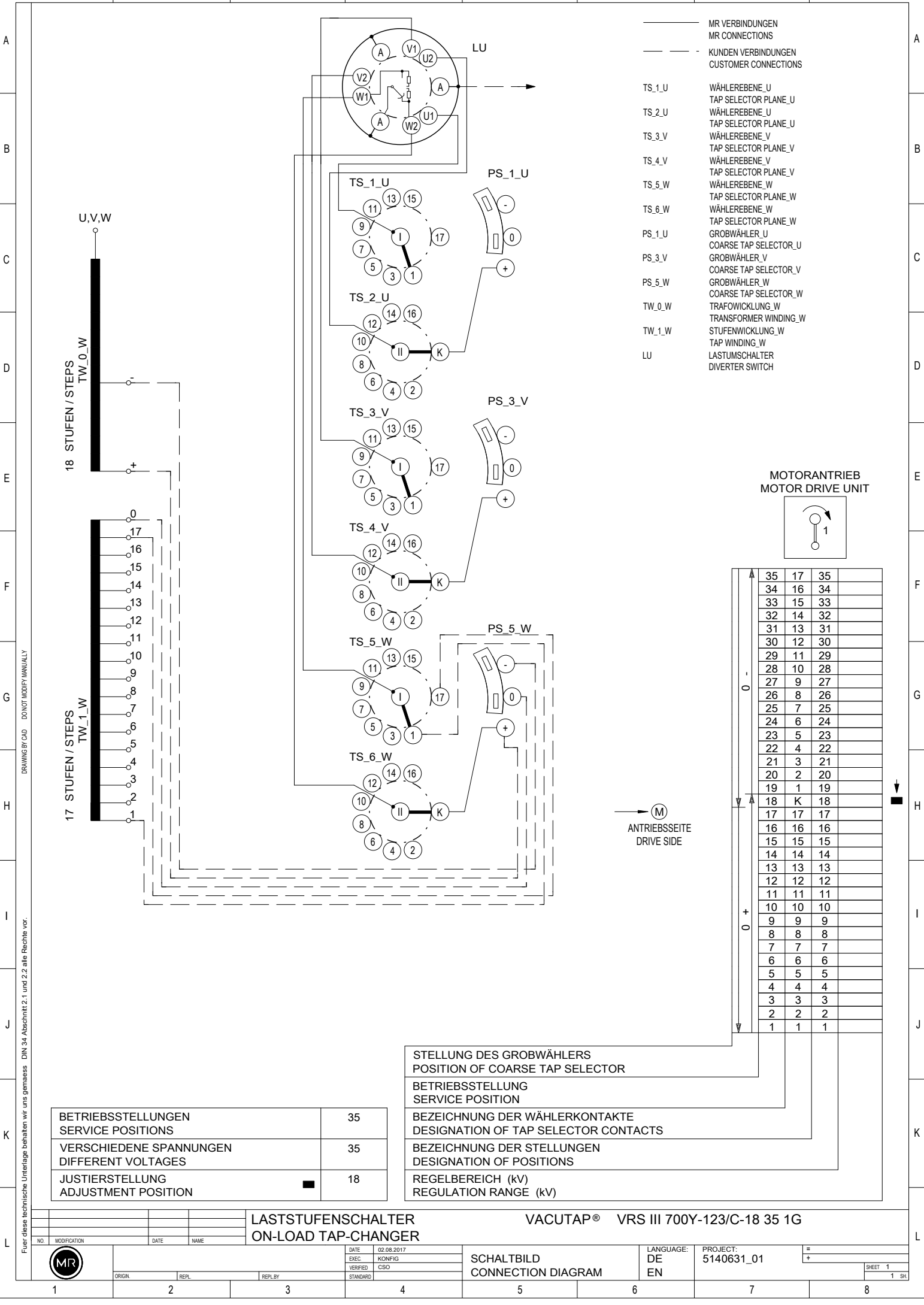

- MR VERBINDUNGEN
MR CONNECTIONS
- - - KUNDEN VERBINDUNGEN
CUSTOMER CONNECTIONS
- TS_1_U WÄHLEREbene_U
TAP SELECTOR PLANE_U
- TS_2_U WÄHLEREbene_U
TAP SELECTOR PLANE_U
- TS_3_V WÄHLEREbene_V
TAP SELECTOR PLANE_V
- TS_4_V WÄHLEREbene_V
TAP SELECTOR PLANE_V
- TS_5_W WÄHLEREbene_W
TAP SELECTOR PLANE_W
- TS_6_W WÄHLEREbene_W
TAP SELECTOR PLANE_W
- PS_1_U GROBWÄHLER_U
COARSE TAP SELECTOR_U
- PS_3_V GROBWÄHLER_V
COARSE TAP SELECTOR_V
- PS_5_W GROBWÄHLER_W
COARSE TAP SELECTOR_W
- TW_0_W TRAFOWICKLUNG_W
TRANSFORMER WINDING_W
- TW_1_W STUFENWICKLUNG_W
TAP WINDING_W
- LU LASTUMSCHALTER
DIVERTER SWITCH

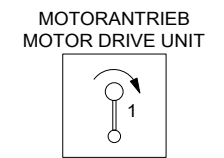

35	17	35
34	16	34
33	15	33
32	14	32
31	13	31
30	12	30
29	11	29
28	10	28
27	9	27
26	8	26
25	7	25
24	6	24
23	5	23
22	4	22
21	3	21
20	2	20
19	1	19
18	K	18
17	17	17
16	16	16
15	15	15
14	14	14
13	13	13
12	12	12
11	11	11
10	10	10
9	9	9
8	8	8
7	7	7
6	6	6
5	5	5
4	4	4
3	3	3
2	2	2
1	1	1

STELLUNG DES GROBWÄHLERS POSITION OF COARSE TAP SELECTOR
BETRIEBSSTELLUNG SERVICE POSITION
BEZEICHNUNG DER WÄHLERKONTAKTE DESIGNATION OF TAP SELECTOR CONTACTS
BEZEICHNUNG DER STELLUNGEN DESIGNATION OF POSITIONS
REGELBEREICH (kV) REGULATION RANGE (kV)

BETRIEBSSTELLUNGEN SERVICE POSITIONS	35
VERSCHIEDENE SPANNUNGEN DIFFERENT VOLTAGES	35
JUSTIERSTELLUNG ADJUSTMENT POSITION	18

LASTSTUFENSCHALTER VACUTAP® VRS III 700Y-123/C-18 35 1G
ON-LOAD TAP-CHANGER

FÜR DIESE TECHNISCHE UNTERLAGE BEHALTEN WIR UNS GEMÄSS DIN 34 Abschnitte 2.1 und 2.2 alle Rechte vor.
 DRAWING BY CAD - DO NOT MODIFY MANUALLY

- MR VERBINDUNGEN
MR CONNECTIONS
- - - KUNDEN VERBINDUNGEN
CUSTOMER CONNECTIONS
- TS_1 WÄHLEREBENE
TAP SELECTOR PLANE
- TS_2 WÄHLEREBENE
TAP SELECTOR PLANE
- PS_1 WENDER
REVERSING CHANGE-OVER SELECTOR
- TW_0 TRAFOWICKLUNG
TRANSFORMER WINDING
- TW_1 STUFENWICKLUNG
TAP WINDING
- LU LASTUMSCHALTER
DIVERTER SWITCH

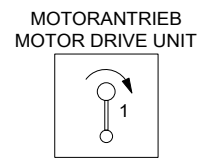
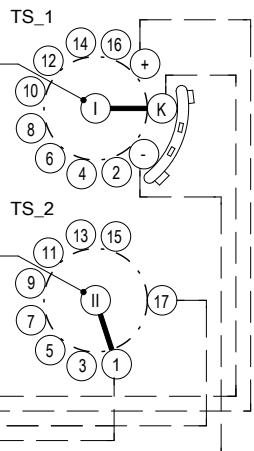
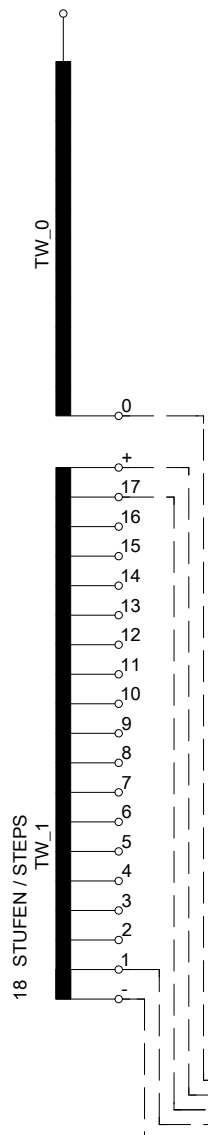
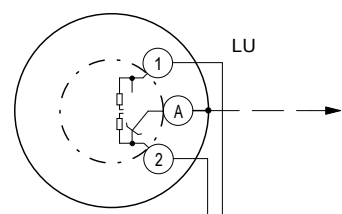

35	17	35
34	16	34
33	15	33
32	14	32
31	13	31
30	12	30
29	11	29
28	10	28
27	9	27
26	8	26
25	7	25
24	6	24
23	5	23
22	4	22
21	3	21
20	2	20
19	1	19
18	K	18
17	17	17
16	16	16
15	15	15
14	14	14
13	13	13
12	12	12
11	11	11
10	10	10
9	9	9
8	8	8
7	7	7
6	6	6
5	5	5
4	4	4
3	3	3
2	2	2
1	1	1

(M) ANTRIEBSSEITE
DRIVE SIDE

DRAWING BY CAD - DO NOT MODIFY MANUALLY

BETRIEBSSTELLUNGEN SERVICE POSITIONS	35
VERSCHIEDENE SPANNUNGEN DIFFERENT VOLTAGES	35
JUSTIERSTELLUNG ADJUSTMENT POSITION	18

STELLUNG DES WENDERS POSITION OF REVERSING CHANGE-OVER SELECTOR	
BETRIEBSSTELLUNG SERVICE POSITION	
BEZEICHNUNG DER WÄHLERKONTAKTE DESIGNATION OF TAP SELECTOR CONTACTS	
BEZEICHNUNG DER STELLUNGEN DESIGNATION OF POSITIONS	
REGELBEREICH (kV) REGULATION RANGE (kV)	

LASTSTUFENSCHALTER VACUTAP® VRS I 701-123/C-18 35 1W
ON-LOAD TAP-CHANGER

NO.	MODIFICATION	DATE	NAME

DATE	01.08.2017
EXEC.	KONFIG
VERIFIED	CSO
STANDARD	

SCHALTBILD
CONNECTION DIAGRAM

LANGUAGE:	DE
EN	
PROJECT:	5140632_01

Maschinenfabrik Reinhausen GmbH

Falkensteinstrasse 8

93059 Regensburg

Germany

+49 941 4090-0

info@reinhausen.com

[reinhausen.com](https://www.reinhausen.com)

Please note:

The data in our publications may differ from the data of the devices delivered.

We reserve the right to make changes without notice.

5224510/09 KO - VACUTAP® VR® 기술 데이터 -

F0346508 - 07/23

Maschinenfabrik Reinhausen GmbH 2023

THE POWER BEHIND POWER.